

José Luis Varela Aldás

Contribuciones a la Rehabilitación  
Cognitiva de Pacientes con  
Enfermedades  
Neurodegenerativas por Medio de  
Realidad Virtual y Dispositivos de  
Bajo Coste

Director/es

Palacios Navarro, Guillermo  
García-Magariño García, Iván

<http://zaguan.unizar.es/collection/Tesis>

© Universidad de Zaragoza  
Servicio de Publicaciones

ISSN 2254-7606



**Universidad**  
Zaragoza

Tesis Doctoral

CONTRIBUCIONES A LA REHABILITACIÓN  
COGNITIVA DE PACIENTES CON  
ENFERMEDADES NEURODEGENERATIVAS POR  
MEDIO DE REALIDAD VIRTUAL Y DISPOSITIVOS  
DE BAJO COSTE

Autor

José Luis Varela Aldás

Director/es

Palacios Navarro, Guillermo  
García-Magariño García, Iván

**UNIVERSIDAD DE ZARAGOZA**  
**Escuela de Doctorado**

Programa de Doctorado en Ingeniería Electrónica

2022





**Universidad**  
Zaragoza

**TESIS DOCTORAL**  
**POR COMPENDIO DE PUBLICACIONES**

**Contribuciones a la Rehabilitación Cognitiva de Pacientes con  
Enfermedades Neurodegenerativas por Medio de Realidad Virtual y  
Dispositivos de Bajo Coste**

**Autor:**

José Luis Varela Aldás

**Directores:**

Dr. Guillermo Palacios-Navarro

Dr. Iván García-Magariño

Departamento de Ingeniería  
Electrónica y Comunicaciones

Departamento de Ingeniería del  
Software e Inteligencia Artificial

**Departamento de Ingeniería Electrónica y Comunicaciones**

**UNIVERSIDAD DE ZARAGOZA**

## *Agradecimientos*

*Deseo expresar mi más sentido agradecimiento a todas las personas que me apoyaron en el desarrollo de este trabajo.*

*Un profundo agradecimiento a los Doctores Guillermo Palacios Navarro e Iván García-Magariño, directores de tesis, por haber confiado en mí, por sus enseñanzas y orientación incondicional.*

*Al Ingeniero Jorge Buele, colaborador de este trabajo, con quien aprendimos juntos de este apasionante mundo de la investigación.*

*Y ante todo un agradecimiento a Dios y mi familia. A mi madre por el ejemplo de vida para sacarnos adelante. A mi esposa por ser ese inmenso apoyo. Y con gran dedicatoria a mi bebe que está por nacer. Los amo.*

## ÍNDICE DE CONTENIDOS

	<b>Pág.</b>
<b>RESUMEN .....</b>	<b>5</b>
<b>ABSTRACT .....</b>	<b>6</b>
<b>BREVE INTRODUCCIÓN .....</b>	<b>7</b>
<b>OBJETIVOS DE LA INVESTIGACIÓN .....</b>	<b>8</b>
<b>1. TESIS POR COMPENDIO DE PUBLICACIONES .....</b>	<b>10</b>
<b>2. INTRODUCCIÓN GENERAL .....</b>	<b>12</b>
Realidad virtual.....	12
Rehabilitación cognitiva .....	15
Rehabilitación cognitiva y RV .....	18
Realidad virtual y tele rehabilitación cognitiva .....	21
Fog Computing .....	22
Trabajos realizados .....	23
<b>3. COPIA DE LOS TRABAJOS PUBLICADOS .....</b>	<b>32</b>
I. Fog computing for assisting and tracking elder patients with neurodegenerative diseases .....	32
II. Immersive virtual reality app for mild cognitive impairment .....	44
III. Head-mounted display-based application for cognitive training .....	58
IV. A Virtual Reality-Based Cognitive TeleRehabilitation System for Use in the COVID-19.....	81
<b>4. DISCUSIONES Y CONCLUSIONES .....</b>	<b>105</b>
<b>4.1 DISCUSIÓN GLOBAL .....</b>	<b>105</b>
Características de las aplicaciones de RV desarrolladas .....	105
Sujetos de estudio y efectos fisiológicos.....	108
Valoración cognitiva .....	108
Tele rehabilitación cognitiva.....	110
Usabilidad de las aplicaciones de RV .....	112
Fog computing.....	112
Limitaciones .....	113

4.2 CONCLUSIONES FINALES.....	113
4.3 TRABAJOS FUTUROS .....	114
<b>5. BIBLIOGRAFÍA .....</b>	<b>118</b>
<b>6. APÉNDICE .....</b>	<b>127</b>
6.1 APÉNDICE 1: Factor de impacto y Área temática de las revistas .....	127
6.2 APÉNDICE 2: Justificación de la contribución del doctorando.....	128
6.3 APÉNDICE 3: Artículos en conferencias.....	129
V. Virtual Reality-Based Memory Assistant for the Elderly .....	129
VI. Effects of immersive virtual reality on the heart rate of athlete’s warm-up. ....	146
VII. Immersive Virtual Reality App to Promote Healthy Eating in Children.....	158
VIII. Memory Diagnostic Application Using the FNAME.....	166



## RESUMEN

La realidad virtual es una tecnología que ha estado en constante desarrollo en las últimas décadas, aportando soluciones para complementar a la medicina tradicional. En particular, la salud cognitiva se ha visto beneficiada con entornos virtuales orientados a la evaluación y rehabilitación del paciente. No obstante, son limitadas las investigaciones realizadas para determinar su validez ecológica. En esta tesis doctoral se evalúan aplicaciones de realidad virtual diseñadas para cribado y rehabilitación cognitiva, incluyendo las aplicaciones orientadas a la tele rehabilitación. Con este objetivo se ha diseñado tareas basadas en dispositivos de bajo coste para sistemas inmersivos y no inmersivos, respectivamente. Bajo esta perspectiva se ha creado un marco de desarrollo para aplicaciones de realidad virtual con diferentes niveles de dificultad, que integran la recolección automatizada de resultados y el intercambio de información con servidores remotos mediante el enfoque de computación en la niebla. Las diferentes tareas han sido validadas en una población de sujetos sanos y con referencia a métodos tradicionales de valoración cognitiva. Para ello, además de utilizar las pruebas de contraste de hipótesis tradicionales, se han utilizado cuestionarios estandarizados y validados de usabilidad y satisfacción. Además, se ha optimizado el ancho de banda de red requerido para la ejecución de las tareas de rehabilitación supervisadas en tiempo real. Nuestros resultados confirman algunos de los obtenidos en investigaciones similares y aportan una mayor evidencia sobre los beneficios de la realidad virtual para la rehabilitación cognitiva, suponiendo, por ende, una base para futuros trabajos que utilicen esta tecnología para el tratamiento de enfermedades neurodegenerativas.

## **ABSTRACT**

Virtual reality is a technology that has been in constant development in recent decades, providing solutions to complement traditional medicine. In particular, cognitive health has benefited from virtual environments oriented to the patient evaluation and rehabilitation. However, the investigations carried out to determine its ecological validity are limited. In this PhD thesis, virtual reality applications designed for screening and cognitive rehabilitation are evaluated, including applications aimed at tele-rehabilitation. With this objective in mind, low-cost device-based tasks have been designed for immersive and non-immersive systems, respectively. From this perspective, a framework for the development of virtual reality applications has been created, which integrates the automated collection of results and the exchange of information with remote servers through the fog computing approach. It also provides different levels of difficulty for every single task. The different tasks have been validated in a population of healthy subjects and with reference to traditional cognitive assessment methods. To perform this, besides using the traditional tests for hypothesis contrast, standardized and validated usability and satisfaction questionnaires have been used. In addition, the network bandwidth required for the execution of the rehabilitation tasks monitored in real time has been optimized. Our results confirm some of those obtained in similar research studies and provide greater evidence on the benefits of virtual reality for cognitive rehabilitation, thus assuming a basis for future work using this technology for the treatment of neurodegenerative diseases.

## **BREVE INTRODUCCIÓN**

En las pasadas décadas se ha experimentado un incremento en la aplicación de la Realidad Virtual (RV) para la rehabilitación de una gran variedad de déficits como resultado de lesiones del sistema nervioso (Holden, 2005; Rose et al., 2005). Las terapias de RV se han aplicado de forma exitosa para tratar de recuperar pacientes de ictus, Parkinson, esclerosis múltiple, Alzheimer y otros (J. H. Crosbie et al., 2006). Esto es así porque estas técnicas se basan en conceptos relevantes para la rehabilitación como el número de repeticiones, alta intensidad y entrenamiento orientado a tareas (Langhorne et al., 2009).

La RV proporciona una experiencia muy motivadora, permitiendo al usuario la práctica de diferentes movimientos a la vez que se manipula un dispositivo de interfaz (Sveistrup, 2004). Los entornos virtuales (EV) pueden ser fácilmente cambiables, permitiendo el diseño de terapias individualizadas y adaptadas a las necesidades de los pacientes. La RV también proporciona estímulos muy ricos y funcionales dentro de contextos motivadores, reforzando y promoviendo una participación más activa del sujeto (Paolucci et al., 2012; Tuena et al., 2019). Son numerosos los estudios que han encontrado incrementos importantes en la motivación y el disfrute, así como mejores rendimientos en los aspectos motor y/o cognitivo tras la finalización de las diferentes intervenciones (Broeren et al., 2008; Walker et al., 2000; Yavuzer et al., 2008).

El ámbito de tecnologías que se consideran RV es muy amplio. Las aplicaciones de la RV van desde sistemas no inmersivos a sistemas completamente inmersivos, dependiendo del grado con el que el usuario es aislado del entorno físico que lo rodea cuando éste interacciona con el EV (Henderson et al., 2007; Smith, 2019).

Este trabajo presenta el desarrollo y la evaluación de sistemas de RV para el diagnóstico y rehabilitación cognitiva usando dispositivos de bajo coste. Las aplicaciones incorporan enfoques para optimizar la gestión remota de la información a través de internet. Las herramientas desarrolladas se validan en referencia a resultados de métodos tradicionales de valoración cognitiva aplicados en participantes sanos. Además, se analiza la viabilidad de las aplicaciones usando la perspectiva del usuario por medio de test de usabilidad.

La memoria de esta tesis doctoral se organiza de la siguiente manera. Tras presentar los objetivos de la investigación, la primera sección enlista los artículos que conforman el compendio de publicaciones realizadas. La segunda sección contiene una introducción general de la investigación y las actividades ejecutadas, mientras que la tercera sección presenta una copia de las publicaciones que conforman esta tesis doctoral. La cuarta sección contiene las discusiones globales de la investigación, las conclusiones finales y aportaciones originales, así como la exposición de líneas maestras para el trabajo futuro.

### **OBJETIVOS DE LA INVESTIGACIÓN**

El objetivo general de la tesis doctoral es el desarrollo de herramientas basadas en RV que contribuyan a la mejora de los procesos de evaluación y rehabilitación cognitiva en pacientes con enfermedades neurodegenerativas (EN). Con esta premisa se han planteado los siguientes objetivos específicos:

- a.- Diseñar tareas de entrenamiento para la evaluación y rehabilitación de la memoria mediante aplicaciones software basadas en RV para su utilización en diferentes tipos de dispositivos como computadores personales, tabletas PC y gafas de RV, poniendo especial énfasis en su aplicabilidad en dispositivos de bajo coste.
- b.- Proponer un marco de desarrollo de aplicaciones con niveles de dificultad modulables de acuerdo con las características de cada paciente o colectivo de pacientes y que sea de utilidad en entornos clínicos.
- c.- Diseñar e implementar tareas de rehabilitación y entrenamiento cognitivo para su uso exclusivo en aplicaciones de tele rehabilitación.
- d.- Validar las diferentes tareas mediante la utilización de grupos de sujetos sanos y con respecto a métodos tradicionales de valoración neuropsicológica mediante el uso de medidas estadísticas de asociación y/o concordancia.
- e.- Utilizar los resultados de la aplicación de las tareas a la población, tales como precisión de las respuestas y tiempos de reacción, para establecer relaciones con las variables de dicha población y proporcionar más evidencia a las investigaciones en rehabilitación cognitiva.

f.- Integrar los sistemas desarrollados con la recolección automatizada de datos usando nuevas tecnologías de la comunicación, tales como computación en la niebla (“fog computing”), con el fin de optimizar el intercambio y almacenamiento de información con servidores remotos.

g.- Evaluar la viabilidad de los sistemas de RV desarrollados, midiendo la usabilidad y la satisfacción en los participantes de las pruebas experimentales a través de cuestionarios estandarizados.

## 1. TESIS POR COMPENDIO DE PUBLICACIONES

La presente tesis doctoral, de acuerdo con el informe correspondiente, autorizado por los Directores de Tesis y el Órgano Responsable del Programa de Doctorado, se presenta como un compendio de cuatro trabajos previamente publicados. Las referencias completas de los artículos que constituyen el cuerpo de la tesis son las siguientes:

- I. García-Magariño, I., **Varela-Aldas, J.**, Palacios-Navarro, G., & Lloret, J. (2019). Fog computing for assisting and tracking elder patients with neurodegenerative diseases. *Peer-to-Peer Networking and Applications*, 12(5), 1225-1235.
- II. **Varela-Aldás, J.**, Palacios-Navarro, G., García-Magariño, I. (2019). Immersive virtual reality app for mild cognitive impairment. *Revista Ibérica de Sistemas y Tecnologías de la Información*, E19, 278–290.
- III. **Varela-Aldás, J.**, Palacios-Navarro, G., Amariglio, R., & García-Magariño, I. (2020). Head-mounted display-based application for cognitive training. *Sensors*, 20(22), 6552.
- IV. **Varela-Aldás, J.**, Buele, J., Ramos Lorente, P., García-Magariño, I., & Palacios-Navarro, G. (2021). A Virtual Reality-Based Cognitive TeleRehabilitation System for Use in the COVID-19 Pandemic. *Sustainability*, 13(4), 2183.

Así mismo, se considera oportuno incluir en el apéndice 3 de la tesis los artículos en conferencias que han constituido parte de la base formativa del doctorando:

- V. Chicaiza, F. A., Lema-Cerda, L., Álvarez, V. M., Andaluz, V. H., **Varela-Aldás, J.**, Palacios-Navarro, G., & García-Magariño, I. (2018, June). Virtual reality-based memory assistant for the elderly. In *International Conference on Augmented Reality, Virtual Reality and Computer Graphics* (pp. 269-284).
- VI. **Varela-Aldás, J.**, Palacios-Navarro, G., García-Magariño, I., & Fuentes, E. M. (2019, June). Effects of immersive virtual reality on the heart rate of athlete's warm-up. In *International Conference on Augmented Reality, Virtual Reality and Computer Graphics* (pp. 175-185).
- VII. Fuentes, E. M., **Varela-Aldás, J.**, Palacios-Navarro, G., & García-Magariño, I. (2020, July). Immersive Virtual Reality App to Promote Healthy Eating in Children. In *International Conference on Human-Computer Interaction* (pp. 9-15).

- VIII. **Varela-Aldás, J.**, Buele, J., Pérez, D., & Palacios-Navarro, G. (2021, February). Memory Diagnostic Application Using the FNAME. In International Conference on Information Technology & Systems (pp. 41-50).

## **2. INTRODUCCIÓN GENERAL**

Este trabajo de investigación se enmarca en el campo de la rehabilitación cognitiva mediante el uso de nuevas tecnologías. En concreto, mediante el uso de técnicas de RV. A continuación, se presentan los temas a tratarse y trabajos relacionados de la literatura.

### **Realidad virtual**

La realidad se entiende como el mundo físico donde el ser humano se desenvuelve y convive con sus similares e interactúa con otros elementos utilizando todos sus sentidos. Desde la antigüedad, las actividades que realiza una persona han requerido su presencia, aunque esta situación ha venido cambiando en los últimos años. Este cambio se ha potenciado por la constante evolución de los medios tecnológicos de comunicación, que han modificado su forma de interactuar con el entorno que lo rodea (Dunn et al., 2017; Wolfartsberger, 2019). Con el avance de la ciencia, han aparecido los sistemas de realidad extendida (RX), que permiten reproducir entornos, personas y objetos con alta fidelidad utilizando un ordenador (Farshid et al., 2018; Yung & Khoo-Lattimore, 2019). La RX incluye la RV, realidad aumentada (RA), y realidad mixta (RM), así como aquellas otras que se desarrollen en el futuro. Todas estas tecnologías han tomado su nombre por su relación con el mundo real.

La RV incluye un conjunto de representaciones virtuales tridimensionales del mundo real (Nilsson et al., 2018). En la literatura encontramos diferentes definiciones. Por ejemplo, Weiss et al. (2016) la definen como el uso de simulaciones interactivas creadas con hardware y software de computadora para presentar a los usuarios oportunidades de participar en entornos que parecen similares a objetos, entornos y eventos del mundo real. La RV también se ha definido como una forma avanzada de interfaz humano-computadora que permite al usuario interactuar, sumergiéndose en un entorno generado por computadora de una manera naturalista (Schultheis & Rizzo, 2001). En cualquier caso, la experiencia multisensorial ofrece un entorno que puede ser ecológicamente válido, con el potencial de mejorar la calidad de vida del usuario.

La RV puede presentarse de diferentes formas según el grado de inmersión: no inmersiva, semi inmersiva y totalmente inmersiva. La RV no inmersiva presenta los EV desde un ordenador convencional o bien se proyectan en una pantalla donde el usuario



controla su movimiento dentro del ambiente artificial por medio de un joystick u otro dispositivo de control (Lange et al., 2012). Una aplicación de RV de escritorio (Desktop-VR) se refiere a cualquier EV que utiliza un monitor de computadora estándar como pantalla visual. La interacción con la Desktop-VR hace uso del ratón y el teclado estándar de la computadora como dispositivos de entrada. Como tal, esta forma de RV es bastante rentable debido a la amplia disponibilidad del hardware necesario para ejecutarla, incluyendo los paquetes de software disponibles para programar los EV. Las aplicaciones de escritorio se han utilizado en la investigación psicológica durante décadas, aunque este término no se aplica de manera uniforme en todos los estudios (Furht, 2008; Smith, 2019).

A caballo entre los sistemas no inmersivos e inmersivos, se encuentran los sistemas semi inmersivos. En estos sistemas, el usuario percibe el mundo real y parte del mundo virtual (Peñasco Martín et al., 2010). En comparación con un sistema no inmersivo, un sistema de RV semi inmersivo consta de gráficos más sofisticados con pantallas de superficie plana más grandes para presentar el EV.

Con el fin de proporcionar al usuario una serie de experiencias que se asemejen a las reales, la RV ha evolucionado implementando los entornos de realidad virtual inmersiva (RVi), ofreciendo la perspectiva de vivir en una realidad simulada (Alcañiz et al., 2019). Este tipo de RV promete una gran cantidad de experiencias e induce estados mentales que van desde lo simple hasta lo exagerado, sensaciones que se combinan para tareas de entrenamiento y aprendizaje de nuevas habilidades, logrando incluso ayudar a las personas sanas a rediseñarse a sí mismas con el fin de alcanzar una vida más significativa y emocionante (Georgiev et al., 2021).

El origen de la inmersión se remonta al año 1957, donde Morton Heiling inventa la denominada Sensorama, una máquina que proyectaba películas tridimensionales, que producía vibraciones y generaba estímulos olfativos (Maples-Keller et al., 2017). Esto dio inicio a la necesidad de brindar al ser humano la posibilidad de vivir experiencias únicas sin salir de su entorno actual. Estas interfaces especializadas contienen gráficos en tiempo real, haciendo que el participante se sienta inmerso en un mundo generado por computador que cambia de una forma natural con el movimiento del cuerpo y la cabeza (Lange et al., 2012). El sistema inmersivo puede consistir en enormes superficies de proyección circundantes o

también gafas de RV, que ubican virtualmente al usuario dentro del EV para un alto nivel de inmersión (García-Betances et al., 2015). Un sistema que utiliza gafas de RV conocidas como Head-Mounted Display (HMD) se considera inmersivo, debido a que el usuario visualiza solo la imagen generada por computador y el resto del mundo físico es bloqueado de la vista (J. Crosbie et al., 2005; Sherman & Craig, 2003). Un sistema de inmersión total puede incorporar un amplio campo de visión, alta resolución, HMD y retroalimentación auditiva, táctil o de fuerza (Sherman & Craig, 2003; Slater, 2018).

Los sistemas de RVi contienen parámetros a considerar, como la inmersión y la presencia que son dos términos a tomar en cuenta en el desempeño del usuario al momento de ejecutar las tareas virtuales (J. Crosbie et al., 2005; Rizzo et al., 2004a). La inmersión está relacionada con la tecnología, mientras que la presencia es una consecuencia cognitiva, perceptual y psicológica de la inmersión. Por otro lado, la presencia se puede entender como la percepción psicológica de “estar en” o “existir en” el EV (Heeter, 1992). El uso de dispositivos HMD podría afectar el sentido de presencia e inmersión impactando de manera directa en el rendimiento de un participante, así como en la motivación (McNeill et al., 2004).

En los últimos años la tendencia en equipos HMD es usar dispositivos independientes, es decir, gafas de RV que contienen todo lo necesario para su funcionamiento. La empresa Oculus VR ofrece diferentes equipos con estas características, ver la Figura 1. Las Gear VR es un equipo portátil que sirve como adaptador para mostrar la pantalla de teléfono móvil como dispositivo HMD. Las Oculus Go por otra parte son gafas de RV totalmente independientes con procesador y sistema operativo Android optimizado para dedicarse únicamente a ofrecer una experiencia mejorada de RV. Lo más reciente son las Oculus Quest, éste es un visor completo con seguimiento de adentro hacia afuera, lo que permite una experiencia inalámbrica de alto rendimiento, a diferencia de los anteriores, incluye dos controladores de mano. Considerando el coste y las prestaciones, las Oculus Go siguen siendo la mejor opción para la mayoría de aplicaciones prácticas (Hillmann, 2019).



**Figura 1.** Gafas de RV de la compañía Oculus VR.

### **Rehabilitación cognitiva**

Las enfermedades neurodegenerativas (EN) se caracterizan por una afectación del sistema nervioso a causa de un aumento de los procesos de muerte celular, reduciéndolas y provocando una degeneración del tejido nervioso. Esto conlleva un deterioro cognitivo, cambios en la conducta, y en el funcionamiento del organismo de la persona que la padece. Este deterioro puede ser leve como un desenlace normal cuando existe una edad avanzada o cuando muestran indicios de algo más grave como la demencia. La demencia es el término más utilizado para abarcar una serie de síntomas como el deterioro de la memoria, el razonamiento, el lenguaje, y/o la percepción. Se utilizan combinaciones específicas de estos síntomas para definir diferentes tipos de demencia, donde las enfermedades del Parkinson (EP) y Alzheimer (EA) son las más populares.

La EA es el tipo más común y suele afectar a los adultos mayores, representando del 60 al 80% de los casos. Uno de los síntomas más notorios es la dificultad para aprender nueva información. El número de personas con demencia de inicio temprano (personas menores de 65 años) también ha aumentado en todo el mundo (Kivipelto et al., 2020). Además, cuando la enfermedad avanza hay otros síntomas tales como desorientación, cambios de humor, comportamiento, confusión sobre eventos, fechas, lugares, así como dificultad para hablar, escribir y caminar (Alzheimer's Association, 2015).

Por otra parte, el deterioro cognitivo en la EP puede aparecer desde etapas tempranas, y los pacientes pueden presentar sutiles alteraciones cognitivas conocidas como deterioro cognitivo leve (DCL). El perfil neuropsicológico inicial es principalmente de tipo no amnésico, caracterizado por disfunción ejecutiva, alteraciones atencionales, déficit de la memoria operativa y fallos en la recuperación de la información. Es precisamente en esta disfunción ejecutiva donde se incluye la resolución de problemas, planificación o memoria de trabajo, las cuales aparecen tempranamente como consecuencia del déficit de dopamina, agravando la situación. Cuando los pacientes desarrollan demencia, surgen alteraciones en el almacenamiento de la información, fluidez semántica y en las habilidades visuoespaciales y visuoperceptuales.

Respecto al diagnóstico, los métodos para detectar la reducción de las capacidades cognitivas se pueden clasificar en invasivos y no invasivos. Los invasivos requieren la obtención de datos desde el interior del cuerpo del paciente, a través de procedimientos tales como punción lumbar o extracción de sangre. Dichas pruebas no siempre son seguras y cómodas para el paciente, y en algunos casos son bastante dolorosas. Por otro lado, las pruebas no invasivas son inofensivas y más adecuadas durante el proceso de diagnóstico.

En los métodos no invasivos, se puede evaluar los aspectos cognitivos del paciente con tareas, cuestionarios y/o problemas. Para detectar síntomas de problemas cognitivos se analizan los dominios más propensos como la atención compleja, función ejecutiva, aprendizaje y memoria, lenguaje, perceptivo-motor y cognición social (American Psychiatric Association, 2013). Las pruebas existentes tratan de examinar áreas cognitivas específicas, como el Mini-Mental State Examination (MMSE), que analiza el aprendizaje, la memoria y los dominios cognitivos del lenguaje (Folstein et al., 1975). El MMSE tiene una puntuación máxima de 30 puntos y el umbral de discriminación o valor de corte es de 24, es decir, los valores inferiores indican algún problema cognitivo y los valores superiores indican lo contrario, aunque el umbral puede aumentarse para evitar falsos negativos (Koné, 2019; Rentz et al., 2011; Tombaugh & McIntyre, 1992).

Un instrumento de cribado cognitivo desarrollado para detectar DCL es la Montreal Cognitive Assessment (MoCA) (Nasreddine et al., 2005). Esta es una prueba simple que evalúa múltiples dominios cognitivos que incluyen la memoria, el lenguaje, las funciones

ejecutivas, las habilidades visuoespaciales, el cálculo, la abstracción, la atención, la concentración y la orientación. Se ha establecido su validez para detectar DCL en pacientes con EA. El test MoCA también es sensible para detectar deterioro cognitivo en enfermedades cerebrovasculares, EP, enfermedad de Huntington, tumores cerebrales, lupus eritematoso sistémico, trastornos por uso de sustancias, trastorno idiopático del comportamiento del sueño con movimientos oculares rápidos, apnea obstructiva del sueño y otros. Este test se desarrolló en un entorno clínico de memoria y se normalizó en una población altamente educada. Hay varias características en el diseño de MoCA que explican una sensibilidad superior para detectar DCL respecto al MMSE. Las pruebas de memoria de MoCA implican más palabras, menos pruebas de aprendizaje, un retraso más prolongado para recordar y tareas numéricas más exigentes (Julayanont & Nasreddine, 2017).

Otro método de diagnóstico es el test Face-Name Associative Memory (FNAME) (Naveh-Benjamin et al., 2004). Esta prueba de memoria asociativa incluye pares de rostro-nombre, en la que se presentan al paciente los rostros con los respectivos nombres de manera secuencial, generalmente con tiempo de 3 segundos por par, de forma que el paciente memoriza uno a la vez. Después del entrenamiento el paciente debe recordar el nombre de cada rostro para obtener una puntuación final. Estos resultados se han relacionado con la memoria explícita (Hampstead et al., 2008; Rentz et al., 2011). En ese sentido, el FNAME ofrece más validez que muchas otras pruebas neuropsicológicas y es adecuado para responder a los requisitos de una buena prueba neuropsicológica (Rubiño & Andrés, 2018).

Por otro lado, existen las técnicas de rehabilitación tradicionalmente utilizadas para mejorar la retención de la memoria. Una técnica de rehabilitación neuropsicológica ampliamente utilizada en la demencia es el método de recuperación espaciada. Esta es una metodología que consiste en aprender nueva información, la cual se recupera de manera continúa aumentando los intervalos de tiempo entre las evocaciones de dicha información (Hopper et al., 2005). La recuperación espaciada se aplica con diferentes variaciones. Por ejemplo, se han realizado estudios modificando la cantidad de recuperaciones y el intervalo de tiempo con el objetivo de mejorar los resultados de la rehabilitación. En el estudio de Karpicke & Bauernschmidt (2011), la introducción de intervalos largos entre todas las

recuperaciones produjo mejoras en la retención a largo plazo, sin importar la cantidad de recuperaciones.

Los avances tecnológicos en la última década han permitido desarrollar pruebas más eficaces utilizando EV. Estos ambientes proporcionan ventajas adicionales a las pruebas cognitivas regulares porque es posible sumergir al paciente en una situación controlada (Tarnanas et al., 2013; Weibel & Wissmath, 2011).

### **Rehabilitación cognitiva y RV**

La estimulación cognitiva es una estrategia fundamental para la rehabilitación de las capacidades mentales y las funciones ejecutivas, como la memoria, la atención, la velocidad de procesamiento y el aprendizaje contextual, evaluando así el comportamiento de los participantes y mejorando las condiciones que influyen el estado de bienestar mental (Gerber et al., 2019).

La rehabilitación cognitiva también se ha beneficiado de la RV. Las herramientas basadas en RV representan una alternativa para el diagnóstico y la rehabilitación cognitiva, que puede ser comparable a los procedimientos convencionales (Sayma et al., 2020). Diferentes estudios han avalado una mejora en las capacidades cognitivas en personas que padecen algún traumatismo, EA, EP, después de sufrir ictus, entre otros (Isernia et al., 2020; Mantovani et al., 2020), demostrando además, unos beneficios para la evaluación neurocognitiva y una validez ecológica significativa (Parsons et al., 2011; Parsons & Courtney, 2011).

Existen estudios experimentales que utilizan la RV para evaluar funciones cognitivas variadas. Vallejo et al. (2017) utilizaron una aplicación de RV con 6 actividades cotidianas para evaluar 18 pacientes con EA. Las funciones cognitivas examinadas fueron la memoria episódica, la memoria prospectiva, la orientación visuoespacial, las funciones ejecutivas, la atención y la velocidad de procesamiento general, encontrando resultados significativamente peores en los participantes enfermos respecto a un grupo de control, en relación a los porcentajes de logro y los tiempos requeridos para completar el juego. La investigación también aplicó un cuestionario de usabilidad, donde los participantes encontraron el juego fácil de usar, disfrutaron jugando y no tuvieron problemas al interactuar. Otro estudio muy reciente usó una aplicación de RV de un supermercado virtual instalado en una tableta para

evaluar el rendimiento cognitivo de pacientes con DCL, además de medir la actividad cerebral usando un electroencefalograma portable y comparar los resultados con un examen tradicional (Iliadou et al., 2021). Concluyeron que la herramienta experimental es útil para la detección de DCL y evaluación cognitiva de forma accesible y agradable para los adultos mayores.

Desde hace varios años ha habido una creciente motivación para desarrollar aplicaciones de RVi orientadas a la cognición humana, con el fin de alcanzar un nivel mayor de inmersión (García-Betances et al., 2015). El grado de inmersión es un punto importante al desarrollar aplicaciones de RV, ya que incluso se ha considerado una dimensión en neuropsicología clínica cuando se evalúa cognición espacial y funciones ejecutivas. El grado en que los participantes se sienten presentes en el EV tiene implicaciones en el desempeño de la tarea, beneficiando positivamente el rendimiento cognitivo de los usuarios al recordar hechos o memorizar elementos (Brade et al., 2017; Krohn et al., 2020).

Con el propósito de estudiar el impacto en el rendimiento cognitivo de los sistemas inmersivos en relación a los sistemas no inmersivos, recientemente se han desarrollado varios estudios. En el estudio de Ventura et al. (2019), se analizó el rendimiento de la memoria episódica través de dos tareas, la primera de ellas bajo un entorno inmersivo y la segunda en un entorno no inmersivo. Las pruebas se realizaron a dos grupos de 21 participantes, visualizando las imágenes de ambos sistemas, pero en orden diferente. La evaluación se realiza usando la técnica de recuperación espaciada. Los resultados mostraron que el grupo que inició con el ejercicio inmersivo obtuvo un mejor desempeño al evaluar la función cognitiva en comparación con el otro grupo.

A pesar de evidencia anterior, no hay suficientes trabajos que respalden la sustitución de una tecnología por la otra (inmersiva vs no inmersiva) para lograr un mejor rendimiento cognitivo. Por ejemplo, los resultados obtenidos por Voinescu y David (2019) no mostraron ninguna evidencia de que exista una relación entre el tipo de entorno y un mejor desempeño. En concreto, utilizaron un entorno de RVi y un entorno de escritorio para evaluar el desempeño de la memoria explícita e implícita en un grupo de 67 personas sanas de entre 19 y 39 años. Esta información motiva al desarrollo de nuevas investigaciones en el campo de la RV para el medir y rehabilitar las funciones cognitivas.

Las aplicaciones RVi orientadas a la memoria han sido probadas mayormente en personas sanas y en pacientes que presentan DCL. Corriveau Lecavalier et al. (2020) utilizan una tienda virtual inmersiva usando el dispositivo HMD Nvisor ST50 para evaluar la memoria episódica en pacientes sanos, quienes deben memorizar 12 elementos. Los resultados indican altos niveles de presencia y motivación, y el rendimiento de la memoria en la tarea de RVi se correlaciona positivamente con el rendimiento en la tarea de memoria tradicional para ambos grupos de edad. Además, el sistema de esta propuesta es sensible a las diferencias bien conocidas relacionadas con la edad debido a que los adultos mayores omiten más elementos que los más jóvenes. Ouellet et al. (2018) presentaron un sistema inmersivo usando el dispositivo HMD nVisor ST50, con un EV conformado a partir de una tienda virtual para evaluar la memoria cotidiana. Los participantes fueron 20 jóvenes sanos, 19 adultos mayores sanos y 35 personas mayores con deterioro cognitivo subjetivo, quienes realizaron la tarea de la tienda virtual. Los resultados obtenidos con el grupo sano permitieron conocer si la propuesta mostraba niveles adecuados de dificultad y así como los efectos de la tarea en la edad, mientras que los resultados del grupo con deterioro cognitivo permitieron relacionar el rendimiento en la tarea inmersiva con el rendimiento de la memoria en dos actividades tradicionales. Las conclusiones indicaron que la precisión de las respuestas en la tarea experimental fue sensible a la edad debido a la obtención de un mejor rendimiento en los jóvenes. Además, este rendimiento se correlacionó con la valoración obtenida en la herramienta tradicional, específicamente con las funciones de la memoria episódica y la velocidad de procesamiento. Por su parte, van Helvoort et al. (2020) desarrollaron una aplicación altamente inmersiva sobre un museo virtual con dos habitaciones. Se validó con participantes jóvenes que debían caminar por EV mientras memorizaban los detalles de cada habitación. Los resultados mostraron que los participantes recordaban más fácilmente los objetos que tenían una menor distancia espacio-temporal entre sí.

Tuena et al. (2020) realizaron una revisión bibliográfica de la RV aplicada a la evaluación y rehabilitación de enfermedades relacionadas con el envejecimiento en adultos mayores. Concluyeron que los sistemas de RV muestran una buena usabilidad y aceptación para este tipo de pacientes, aunque señalan que tan solo se han probado un bajo número de tecnologías inmersivas y por ello podría existir un alto riesgo de sesgo de los estudios. Laver



et al. (2017) en su revisión ya advirtió del escaso número de estudios controlados aleatorios (ECAs) que incluyen rehabilitación y/o evaluación cognitiva usando RV.

### **Realidad virtual y tele rehabilitación cognitiva**

Según la OMS, la telemedicina es la prestación de servicios de salud mediante el uso de las tecnologías de la información y la comunicación, con el fin de intercambiar información entre el profesional de salud y el paciente. Los datos que se obtienen al utilizar estos sistemas interactivos son más fáciles de almacenar y procesar, permitiendo la prevención, diagnóstico y tratamiento de enfermedades de mejor manera (Alhalaili et al., 2020). Un campo recientemente explorado por la RV es la tele rehabilitación cognitiva, que permite proveer de mejores servicios de salud mental que ayuden atender las necesidades de los pacientes desde la comodidad de sus hogares. El uso de las técnicas de rehabilitación a distancia o tele rehabilitación es relativamente nuevo (Isernia et al., 2020). En concreto, se encontraron algunos estudios de entrenamiento cognitivo usando RV en los trabajos de Lawson et al. (2020) y Sarfo et al., (2018). La creciente tendencia en el desarrollo de estas aplicaciones se ha visto acelerada por la pandemia del COVID-19. Esto ha generado la necesidad de sesiones síncronas que logran mejores resultados respecto a las actividades asíncronas de rehabilitación cognitiva del paciente, debido a que la ausencia del especialista médico requiere un mayor compromiso del paciente para realizar las actividades de rehabilitación de forma independiente (Manenti et al., 2020). Todo lo anterior tiene aún más relevancia cuando se dan situaciones extremas como el advenimiento inesperado de la pandemia del COVID-19, que dificulta el contacto social y la interacción humana.

La pandemia de la COVID-19 ha producido el aislamiento social de muchas personas, generando el desarrollo de trastornos mentales (Mantovani et al., 2020). Una investigación reciente realizó una breve revisión en la que destacaba como las aplicaciones de RV han permitido que los especialistas provean de terapias a sus pacientes en tiempos de la pandemia COVID-19 (Imperatori et al., 2020). Otra de las recomendaciones de la OMS es limitar al máximo el desplazamiento de las personas fuera de sus hogares. Es así que Mantovani et al. (2020) ofrecieron una visión general de como la RV ha contribuido a los procesos tele rehabilitación cognitiva y su intensificación motivada por esta crisis sanitaria mundial. Además, Matsangidou et al. (2020) desarrollaron un sistema de RV multiusuario en el cual

el terapeuta interactúa con pacientes con desórdenes alimenticios de forma remota. A pesar de que los participantes no conocieron previamente a los terapeutas de forma física, la comunicación en tiempo real y su representación virtual permitieron desarrollar confianza y seguridad en las sesiones.

Aunque se ha limitado el contacto físico, es importante recalcar que el uso de la telemedicina no pretende reemplazar la prestación de servicios de salud convencionales, sino que debe ser vista como un medio integrador que busca hacerlos más eficientes y asequibles para el usuario. Todo esto sin descuidar los principios de confidencialidad y la ética profesional que debe acompañar a cualquier práctica sanitaria (Scott Kruse et al., 2018). Autores como Jain y Mehrotra (2020) han analizado el grado de aceptación del uso de la telemedicina en comparación con las terapias convencionales, teniendo mayor aprobación en adultos jóvenes, que asignaron una mejor calificación a la atención en línea.

La RV ha sido utilizada para la tele rehabilitación de enfermedades cognitivas en los últimos años. Una revisión a este tema destaca aquellos factores positivos que un ambiente inmersivo le otorga al paciente durante su tratamiento, y a la par se describen las limitaciones y confusiones que surgen comúnmente, motivando al mejoramiento de las plataformas de tele rehabilitación (Tierl et al., 2018). El trabajo de Isernia et al. (2020) demostró que con un programa adecuado de tele rehabilitación, un grupo de pacientes con principios de EA pudo fortalecer su memoria. Pacientes que han padecido un ictus, también han recibido tele rehabilitación cognitiva usando RV y han conseguido una mejoría notable en comparación con los procesos comunes (Sarfo et al., 2018; Torrisi et al., 2019).

### **Fog Computing**

Una tecnología vinculada a la RV es el uso de internet y servidores remotos para el intercambio y almacenamiento de información, como es el caso de las aplicaciones multiusuarios y las aplicaciones distribuidas. Estos requerimientos han propiciado el desarrollo de nuevas arquitecturas de red que optimizan el consumo de datos. La computación en la niebla (“fog computing”) puede reducir el ancho de banda de las comunicaciones al aumentar el procesamiento local y transmitir solo la cantidad esencial de información (Farahani et al., 2018). Las aplicaciones que involucran la transmisión de

imágenes por internet son un claro ejemplo de arquitecturas que sobrecargan el ancho de banda (Collotta et al., 2018).

La computación en la niebla permite reducir el ancho de banda necesario al administrar la información de manera más eficiente y distribuida (Rahmani et al., 2018). Esto se logra analizando localmente la mayoría de datos y enviar únicamente la información relevante a la nube (Hu et al., 2017). Con el advenimiento de las tecnologías móviles, se han diseñado diferentes sistemas de RV (Doniger et al., 2018; Fernandez Montenegro & Argyriou, 2017; Ouellet et al., 2018), pero pocos aprovechan los beneficios de la computación en la niebla creando limitaciones en las aplicaciones.

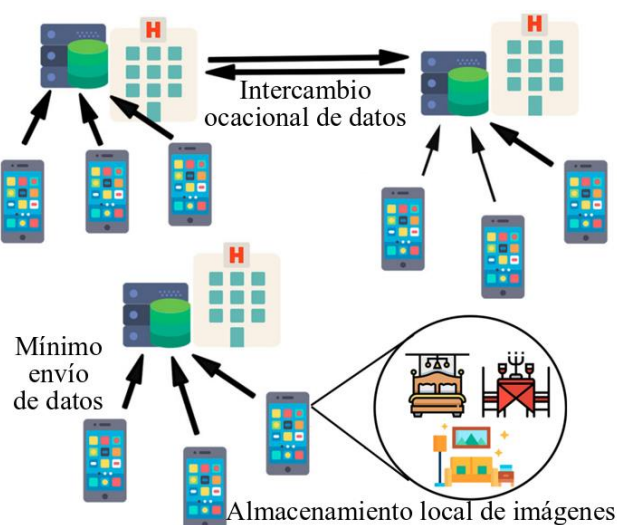
En aplicaciones de diagnóstico y tratamiento de pacientes con EN se requiere normalmente el uso de imágenes y audio, por lo que la cantidad de datos puede llegar a sobrecargar las redes sanitarias. Es así que el enfoque “fog computing” ejecuta una gestión de datos más eficiente y distribuida, aumentando el procesamiento local, comprimiendo el ancho de banda de las comunicaciones y transmitiendo únicamente la información necesaria para el personal de salud (Farahani et al., 2018; Hu et al., 2017). Esto ha permitido el desarrollo de múltiples aplicaciones, como el monitoreo continuo de las enfermedades crónicas en niños (Sendra et al., 2018), así como para la supervisión remota de todo tipo de pacientes (Lloret et al., 2017). Asimismo, puede ser usada por los usuarios para controlar sus indicadores de salud y notificar al centro médico cuando están fuera del rango normal para la respectiva teleasistencia (Kao et al., 2018).

### **Trabajos realizados**

Además de los trabajos publicados en congresos del ámbito, la investigación realizada en este doctorado se distribuye fundamentalmente en cuatro artículos de investigación (tres de ellos publicados en revistas indexadas en el JCR y uno de ellos indexado en el SJR). Siguiendo un orden cronológico, el primero de ellos es un estudio para el rastreo y seguimiento de adultos mayores a través de la simulación del tráfico de comunicaciones usando el paradigma de computación en la niebla (“fog computing”). El segundo trabajo desarrolla un primer prototipo de aplicación para el entrenamiento cognitivo usando RVi, por medio un EV interactivo con navegación activa en primera persona y compatible con un dispositivo HMD basado en un teléfono inteligente. El tercer estudio evalúa una propuesta

de evaluación de la memoria basada en una aplicación de RVi, mejorando las características del prototipo previo e incorporando comunicación con un servidor remoto a través del enfoque del primer trabajo. Finalmente, el cuarto trabajo presenta una propuesta para tele rehabilitación cognitiva basada en una aplicación de RV no inmersiva. Esta incluye características multiusuario con dos roles de acceso (paciente y terapeuta), con navegación en primera y tercera persona, y con comunicación en tiempo real con un ancho de banda muy reducido.

En la primera investigación se utiliza una aplicación móvil para asistir y dar seguimiento a pacientes con EN usando el enfoque de computación en la niebla, ver la Figura 2. La aplicación consiste en presentar escenarios para luego solicitar alguna acción o evaluar la memoria mediante preguntas. La evaluación se realiza mediante preguntas relacionadas con los escenarios, contando las respuestas correctas y aplicando los respectivos factores de ponderación. Las imágenes de los escenarios se almacenan localmente en cada dispositivo móvil, evitando una sobrecarga de la red. Lo único que se envía por internet son los resultados de la evaluación final, que es una cantidad baja de información. Por lo tanto, la mayor parte del procesamiento se realiza localmente. Además, siguiendo el enfoque “fog computing”, cada paciente está asociado con su hospital de afiliación, y por tanto la aplicación solo envía datos al servidor de este hospital. De esta forma, se reduce la posibilidad de que el servidor de datos de cada hospital se convierta en un cuello de botella, debido a que la recopilación de datos se distribuye entre los hospitales.



**Figura 2.** Esquema del enfoque propuesto basado en fog computing.

Con esta propuesta, los médicos de un hospital pueden acceder directamente a los resultados de los pacientes de su hospital. En el caso de requerir los resultados de un paciente vinculado a otro hospital, esta información es enviada al servidor del hospital local. Lo anterior solo ocurre ocasionalmente para mantener distribuida la carga de trabajo en los servidores. Si un paciente cambia de residencia, los datos históricos son movidos, y posteriormente la aplicación del paciente se asocia a su nuevo hospital.

La aplicación propuesta se basa en FAMAP (A Framework for Developing m-Health Apps) (García-Magariño et al., 2018), que se mejora con imágenes en las opciones de respuesta para responder las preguntas. Esta aplicación fue desarrollada en Unity (San Francisco, CA, USA) con el lenguaje de programación C#. Para probar el rendimiento de la propuesta, se simula el tráfico de datos de la aplicación cuando es usada por varios pacientes ubicados en algunos estados de los EE.UU. Por su parte, el número de dispositivos con la aplicación se establece usando los datos de un informe oficial de 2017 sobre EN comunes (Alzheimer's Association, 2017), seleccionando 14 estados con 120.000 pacientes o más.

El enfoque propuesto se comparó con otras 2 alternativas. La primera alternativa utiliza un servicio web al que se accede desde un navegador, mientras que la segunda alternativa es otra aplicación móvil que almacena localmente las imágenes y el procesamiento, aunque todos los datos resultantes se envían a un único servidor. Para realizar la comparativa se utiliza una técnica de simulación basada en agentes (Agent-Based Simulation)(García-Magariño et al., 2017), con el fin de simular el intercambio de información de cada enfoque (propuesta y las 2 alternativas). Este enfoque ofrece una gama más amplia de opciones para decisiones no deterministas, y es apropiado para simular cuándo los pacientes deciden usar la aplicación. Específicamente, se usa una distribución normal, con una desviación estándar (DE) de 0,2, con una media de 0,5 en el intervalo de 0 a 1. Se simula un mes de 30 días, obteniendo tanto el número de solicitudes al servidor y los datos transmitidos de cada opción. Se consideró que el 1 % de los pacientes de los 14 estados seleccionados fueron usuarios habituales de la aplicación, con una frecuencia de uno de cada tres días en promedio y una cantidad de datos transferidos de 0,60 KB.

Los resultados de las simulaciones proporcionaron una estimación de la utilidad de nuestro enfoque. En la comparación diaria de transmisión de datos, la primera alternativa del

servicio web fue 300.000 veces mayor en la cantidad de información intercambiada, respecto al enfoque propuesto. En la segunda alternativa, el promedio de datos transmitidos fue de 13,80 veces más que el enfoque propuesto. De forma similar, comparando el número de conexiones entre los diferentes enfoques, el servicio web necesitó de 600 veces más de conexiones al servidor respecto al enfoque “fog computing”. Por su parte, la segunda alternativa requirió en promedio 14,82 veces más de conexiones al servidor en relación al enfoque propuesto. En definitiva, la propuesta es mejor en comparación con ambas alternativas, pero los resultados de datos transmitidos y número de conexiones obtenidas con la aplicación móvil de la segunda alternativa son proporcionales al número de servidores de la propuesta “fog computing”. Es decir, el único servidor de la aplicación alternativa realiza el trabajo de los 14 servidores de la propuesta, un hallazgo a considerar al momento de implementar una arquitectura. Sin embargo, son notorios los beneficios de la computación en la niebla, por lo que este enfoque se utilizó en los trabajos de investigación subsiguientes.

Los siguientes trabajos se orientan al estudio de propuestas de evaluación cognitiva basadas en aplicaciones de RV con mayor grado de complejidad, donde el doctorando no contaba con la experiencia suficiente para desarrollar este tipo de sistemas. Por ello, la segunda investigación tuvo propositivos introductorios en el mundo de la RVi destinada al entrenamiento cognitivo. Se realizó el diseño de un primer prototipo de tarea que involucró múltiples funciones cognitivas y replicaba acciones cotidianas. Buscando soluciones de bajo coste se propuso el uso de un teléfono inteligente como dispositivo HMD, utilizando la adaptación de las Gear VR, que incluyen un controlador de mano inalámbrico para interactuar con el EV. Aunque esta opción de desarrollo tiene ventajas como el bajo precio (130 USD aprox.) y el soporte en línea, está limitada a los teléfonos Galaxy de la marca Samsung.

La actividad implementada incluyó múltiples estímulos cognitivos como la orientación espacial, la memoria trabajo y la memoria episódica. La tarea se basó en una navegación por diferentes laberintos (el grado de dificultad podía modularse), donde el usuario se desplazaba en primera persona y memorizaba una serie de elementos. Es decir, el jugador debía resolver el laberinto desde dentro, observando previamente un pequeño mapa del mismo desde una vista aérea. Mientras el jugador avanza se encuentra con figuras

geométricas que recoge en el camino con retroalimentación de audio, y al salir del laberinto debe recordar los elementos visualizados en el trayecto. Para el desarrollo del sistema se construyen individualmente los laberintos con las herramientas de Unity 3D, se programan acciones de los elementos del juego (“GameObjects”) mediante Scripts en lenguaje C#, y se implementan 3 niveles de dificultad para la misma actividad.

La Figura 3 muestra la aplicación de RV implementada en las Gear VR. Para estas pruebas se utilizó un teléfono Samsung Galaxy S8+ y fue evaluada por un solo participante sano de 60 años de edad generando las puntuaciones y tiempos de ejecución en los 3 niveles de dificultad por un tiempo de 5 días. El participante logró mejores puntuaciones a medida que utilizaba el juego, realizando 3 juegos diarios con un total de 15 partidas en los 5 días. Al final de la intervención se aplicó un test general de usabilidad (Brooke, 1996), obteniendo la aplicación una buena calificación (85/100) en esta materia.



**Figura 3.** Aplicación de RV implementada en las Gear VR.

Esta primera experiencia de RVi evidenció algunos problemas. Por un lado, el dispositivo HMD utilizado dependía de un teléfono inteligente por lo que el usuario podía ser interrumpido en medio de una sesión por alguna notificación o llamada. Por otro lado, y aunque el adaptador tiene bajo coste, los teléfonos requeridos para su funcionamiento tienen costes elevados. Los laberintos de la aplicación se diseñaron de forma individual complicando el trabajo de desarrollador para lograr varios niveles y múltiples laberintos a

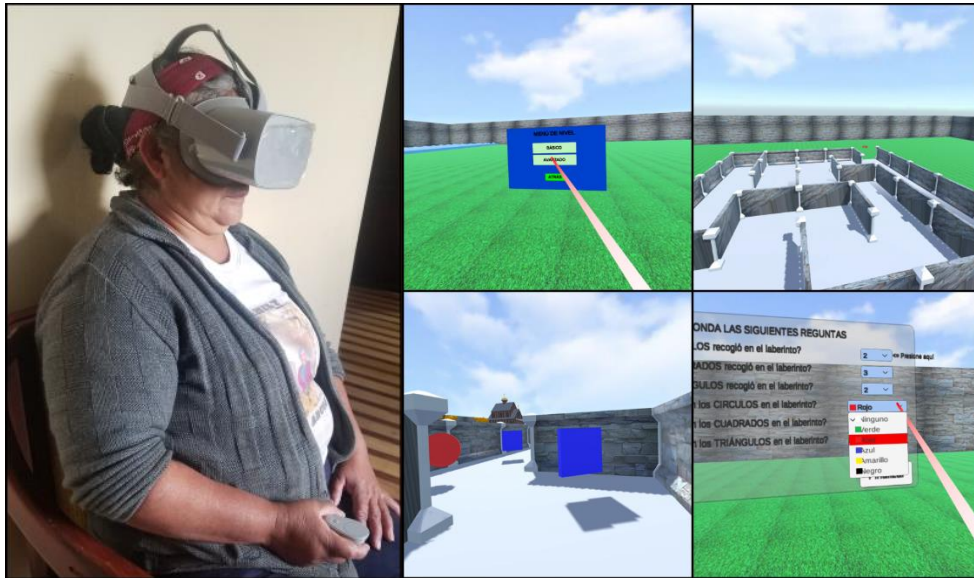
resolver, lo que producía redundancia. Además, los resultados generados en la aplicación se visualizan dentro del EV y no se podían extraer de forma física, ni a través de acceso remoto.

El tercer trabajo analizó una propuesta inmersiva de evaluación de la memoria validando los resultados obtenidos mediante su comparación con aquellos obtenidos con una técnica tradicional de evaluación de memoria. El sistema propuesto considera los aprendizajes de las dos primeras investigaciones, unificando el enfoque del primer trabajo junto con las experiencias técnicas del segundo trabajo. Esta nueva aplicación tuvo que desarrollarse completamente, debido a que los componentes virtuales principales (laberintos) debieron construirse de manera automática, usando el método recursivo puro basado en celdas, que permitió la fabricación aleatoria de laberintos según el número de celdas deseadas. De esta manera se consigue que los laberintos no se repitan y las figuras geométricas también pueden instanciarse de forma automática en el interior del laberinto.

La aplicación de RVi así creada (*AppLab*) incluyó dos formas de juego, una manual y otra autónoma. En la forma manual el jugador tiene el control de sus movimientos y debe resolver el laberinto por su cuenta. Por el contrario, en la forma autónoma el jugador solo se preocupa de memorizar los elementos y el sistema lo traslada automáticamente hacia la salida a una velocidad establecida previamente. De esta manera se pudo explorar los resultados de la memoria con y sin distractores.

Todos los resultados generados en *AppLab* se guardan en el dispositivo de forma accesible y se envían a un servidor remoto SFTP de la Universidad de Zaragoza habilitado a tal efecto. En este punto se aplicó el enfoque “fog computing” validado en el primer trabajo de investigación y evitando así transferir información innecesaria y enviando únicamente los resultados finales. Los resultados quedaban entonces accesibles desde cualquier parte del mundo. Respecto al dispositivo HMD empleado, *AppLab* utiliza las gafas de RV Oculus Go, que son totalmente autónomas y mantienen el bajo coste (200 USD). A diferencia del primer prototipo realizado, el sistema tendrá exclusividad para diagnóstico y rehabilitación. La Figura 4 muestra imágenes de la aplicación de RVi implementada en las Oculus Go.





**Figura 4.** Aplicación de RVi implementada en las Oculus Go.

El sistema propuesto fue evaluado por 29 participantes sanos con edades entre 18 y 64 años, que fueron elegidos usando un test neuropsicológico de valoración rápida (MMSE). Para la validación de los resultados se utilizó una herramienta tradicional de diagnóstico, el test FNAME que utiliza pares de rostro/nombre para evaluar la memoria, como se describió anteriormente. Se forma complementaria se aplicó un test de usabilidad especializado en aplicaciones de RV conocido como USEQ (Gil-Gómez et al., 2017).

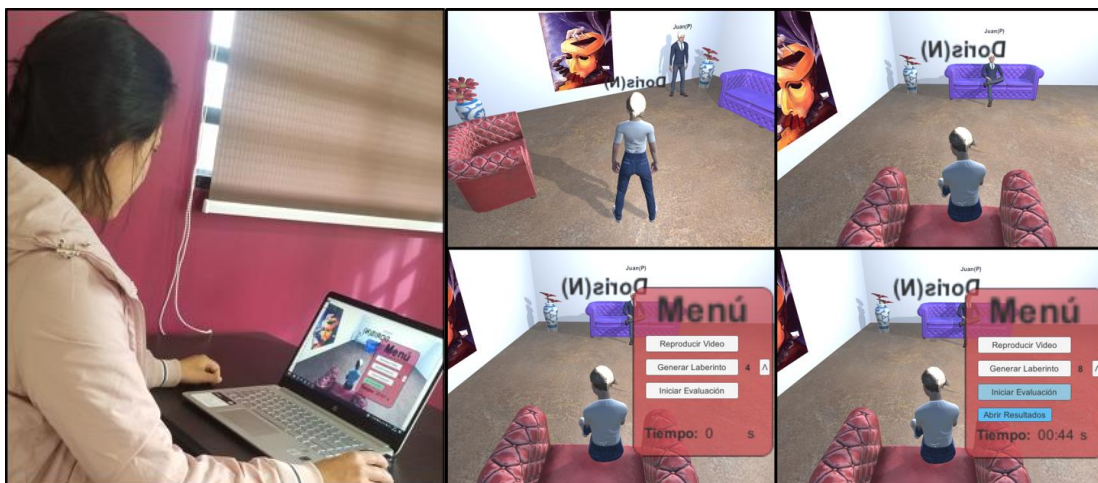
Los resultados obtenidos en los dos niveles de dificultad incluyeron las puntuaciones en ambos modos de juego (manual y autónomo), así como los tiempos de reacción o de completitud de la tarea en el modo manual. Nuestro método se validó con el coeficiente de correlación de Pearson para ver el grado de asociación entre ambos métodos. Se encontró una correlación significativa y grande de acuerdo con Cohen (1988), lo que demuestra un grado de asociación elevado y por tanto, una evidencia de que nuestra herramienta puede utilizarse igualmente para la evaluación de la memoria. Finalmente, los resultados del test de usabilidad mostraron unas puntuaciones elevadas.

El cuarto trabajo desarrolló una propuesta de tele rehabilitación basada en RV y utilizando la experiencia adquirida en las investigaciones previas. Esta investigación tomó mayor relevancia con la aparición del coronavirus SARS-CoV-2, ya que los centros médicos tuvieron que modificar la forma de brindar sus servicios, incluyendo los centros de

tratamiento neuropsicológico, de tal forma que la tele rehabilitación se convirtió en una estrategia común para evitar el contacto entre personas.

El propósito de la investigación era el de analizar una herramienta de tele rehabilitación accesible para la sociedad y sostenible en el tiempo. En un primer momento se pensó en una solución basada en dispositivos móviles, pero el reducido tamaño de pantalla de los teléfonos y el escaso de número de tabletas disponibles fueron las limitantes. Por ello se optó por desarrollar un sistema de escritorio basado en computadora, dispositivo muy accesible y de uso común en los hogares y consultorios neuropsicológicos.

La aplicación de tele rehabilitación cognitiva basada en RV (*AppTele*) consiste en un EV presentado en la pantalla de computador y controlada usando los periféricos básicos de entradas y salida (teclado y el ratón para controlar el EV y micrófono y altavoz para intercambio de información entre las estaciones). La aplicación se desarrolló en Unity 3D y lenguaje C#. Para la comunicación se utilizaron las librerías de Photon, una plataforma de multijugador en red, que permite intercambiar información como los datos de la aplicación y el audio del usuario. El sistema se controló a través de un avatar, presentándose éste desde una vista en primera persona para el paciente y en tercera persona para el neuropsicólogo o terapeuta que lo está tratando. Los personajes se mueven a voluntad de los usuarios y el ambiente virtual proporciona las opciones para facilitar la aplicación de herramientas neuropsicológicas mediante menús y material multimedia. La Figura 5 muestra imágenes de la aplicación *AppTele*.



**Figura 5.** Aplicación de tele rehabilitación cognitiva basada en RV.

La técnica neuropsicológica utilizada en este estudio es la recuperación espaciada (Hopper et al., 2005). Las funciones cognitivas activadas son la memoria de trabajo, memoria inmediata y la memoria episódica. El procedimiento consiste en presentar una historia con una serie de elementos, para posteriormente evaluar los elementos que aparecieron en la misma. A continuación, se distrae al paciente mediante la realización de una actividad diferente por un tiempo determinado. En nuestro caso, utilizamos como elemento distractor la resolución de laberintos de diferentes niveles de dificultad. Finalmente, se concluye con una nueva evaluación con los elementos de la historia mostrada. La historia se presentó mediante un video con caricaturas y la evaluación se realizó a través de un menú de imágenes.

En la *AppTele* todos los archivos necesarios para el procedimiento se cargan localmente en cada computador, transmitiendo a la nube únicamente las órdenes para actualizar los objetos del EV y el audio de los usuarios. Los resultados se almacenan solo en la estación del neuropsicólogo, mediante un archivo en formato de hoja de cálculo que registra los datos del usuario, las calificaciones obtenidas y los tiempos de reacción.

Para validar los resultados de la aplicación desarrollada, se utilizó un grupo de control que realizó los ejercicios siguiendo el método tradicional. Tanto el grupo de control como el grupo experimental se conformaron con 20 participantes sanos con edades entre 18 y 65 años de edad. En general, los resultados mostraron diferencias significativas a favor del grupo experimental (grupo de tele rehabilitación) en cuanto a mejora en el rendimiento de la tarea. mejores puntuaciones. La valoración de usabilidad, además, fue sobresaliente. Se analizaron también los requerimientos de velocidad de subida y bajaba en transmisión de datos obteniendo valores mínimos que garantizan la aplicabilidad de esta propuesta. Esto se logra con el enfoque de la primera investigación, que recomienda almacenar localmente la mayor cantidad de información, mientras sea posible.

### **3. COPIA DE LOS TRABAJOS PUBLICADOS**

#### **I. Fog computing for assisting and tracking elder patients with neurodegenerative diseases**



# Fog computing for assisting and tracking elder patients with neurodegenerative diseases

Iván García-Magariño<sup>1,2</sup> · José Varela-Aldas<sup>3</sup> · Guillermo Palacios-Navarro<sup>4</sup> · Jaime Lloret<sup>5</sup>

Received: 13 July 2018 / Accepted: 17 February 2019  
© Springer Science+Business Media, LLC, part of Springer Nature 2019

## Abstract

U.S. hospitals transmit and manage great amounts of information with the avenue of Internet of things. This work departs from a real need detected by healthcare centers and hospitals in U.S., Spain and Ecuador. This work focuses on the application of fog computing for obtaining an app rich in visual content that will not overload U.S. hospital infrastructures even if it was used massively. The simulation results showed that the proposed fog-based approach could support a regular use (one day out of three on average) by 1% of patients of one of the most common neurodegenerative diseases in 14 states in U.S (i.e. 36,400 patients in total) with only a traffic of 528 KB per day on average when using one hospital per state.

**Keywords** Fog computing · Neurodegenerative disorder · Virtual reality · Mobile application · Agent-based simulation

## 1 Introduction

Hospitals are integrating the use of Internet of Things (IoT) in medical devices for life-critical health monitoring, increasing the demand for greater bandwidth for communications. Emergent solutions in medical IoT are facing challenges such as the information sharing and collaboration among heterogeneous sensor-enabled medical devices and battery lifecycle of the corresponding wearable and portable devices [1]. Fog computing can reduce the bandwidth of communications by augmenting the local processing and only transmitting the essential amount of information required by the hospital and healthcare providers [2].

Clinical trials involving the transmission of images are one of the overloading activities on the bandwidth of healthcare networks [3]. More concretely, the assessment of

patients with neurodegenerative diseases normally requires using images, so patients perceive visual stimuli.

Continuous remote health monitoring is gaining relevance in the late years for allowing caregivers to keep track of some health indicators. For example, a smart system is now able to monitor children with chronic illness by means of wearable sensors and a smartphone, and this alerts the caregivers when some indicators such as heart rate or body temperature surpass certain thresholds [4]. In addition, there is an architecture for remote monitoring in e-Health systems [5]. This architecture relies on using 5G networks for using a proper bandwidth. It also uses big data analytics for alerting of anomalous situations by analyzing the information collected by wearable sensors. In addition, the field of mobile health applications with efficient management of data transmission is growing with a high impact in the society. For instance, an Android-based self-managed mobile application can assist users in collecting and monitoring health indicators for warning care services when appropriate [6]. This app provides self-care for people with chronic illnesses, and constitutes an example of how hospitals can facilitate efficient data communications for telecare.

Fog computing allows e-Health systems to reduce the necessary bandwidth by managing the information more efficiently and in a more distributed way [7]. This is achieved by analyzing most of the data locally and only

---

This article is part of the Topical Collection: *Special issue on Fog Computing for Healthcare*  
Guest Editors: Han-Chieh Chao, Sana Ullah, Christos Verikoukis, and Ki-Il Kim

---

✉ Jaime Lloret  
jlloret@dcom.upv.es

Extended author information available on the last page of the article.

sending the summarized relevant information to a cloud [8]. The existing applications of fog computing for e-Health have different purposes. For example, fog computing has been applied for long-term monitoring of Electrocardiogram (ECG) signals [9], but it has also been applied for monitoring patients with mild dementia in smart home environments for ambient-assisted living [10]. However, to the best of the authors' knowledge, fog computing has not been applied yet for assisting and tracking the evolution of elder people through with neurodegenerative disease through an application of virtual reality (VR).

In this context, we have developed a mobile application for the early detection and tracking of some neurodegenerative disorders with VR. This app relies on the fundamentals of fog computing, in which the images and 3D scenes are stored locally, and the user's replies and actions are processed locally as well. Each app instance sends the data to the local hospital following the principles of fog computing. In this approach, hospitals only interchange patients' data when necessary, for example when a patient changes his or her residence from one city to another or in case of emergencies.

This article is organized as it follows. The next section reviews the most relevant related work, highlighting the main literature gap covered by the proposed fog-based approach. Section 3 introduces the materials and methods of the proposed fog-based approach, including the novel app for elder people with neurodegenerative disorders with a fog-computing approach and the evaluation method of the experiments. Section 4 presents the main results of the experiments discussing the most relevant aspects. Finally, Section 5 mentions the conclusions and depicts some future research lines.

## 2 Related work

The emerging technologies in machine-to-machine (M2M) communications have allowed to interconnect a wide range of wireless devices for implementing m-health applications [11]. Wireless body area networks are the most common ones in the patient's side, but M2M technologies also support applications that can benefit healthcare providers. In the context of ambient assisted living (AAL), Kartsakli et al. [12] proposed a communication framework that kept data exchange and storage at a local data plane, but moved the coordination to the cloud. Their framework was mainly designed to support healthcare applications, and showed performance gains. This system is related with some principles of fog computing since most of the processing and exchange was performed locally. However, their approach was more focused on AAL rather than tracking the development of people with neurodegenerative

disorders through data collection from technologically-supported cognitive assessment.

Several works have specifically applied fog computing for health systems. For example, the prototype Smart e-Health Gateway called UT-GATE [7] uses a geo-distributed intermediary layer for managing the information of sensor nodes and storing these in the cloud. They evaluated their approach with a health monitoring system with an assessment platform based on IoT early-warning scores. In addition, Mahmoud et al. [13] presented a fog-computing strategy for managing IoT information from healthcare systems before uploading to the cloud. It places some tasks of applications in fog devices with an energy-aware allocation strategy. Their experiments with the iFogSim simulator showed the energy-consumption reduction of their approach over the cloud-only strategy and the fog-default one. Furthermore, Wu et al. [9] applied fog computing for long-term monitoring of ECG signals with a t-shirt as the wearable carrier of the corresponding sensors. They evaluated tactile comfort, signal to noise ratio and thermal conductivity, obtaining promising results. Fog-computing has also been applied in the context of ambient assisted-living [10]. In particular, eWALL fits the regulations and procedures requirements for patients with mild dementia. It used a computational-distributed approach following the fog computing principles. The home environment processed the sensed information for not overloading the communications.

Agent-based simulators (ABSs) have simulated communications in different network types for assessing these. For instance, an ABS simulated the communications of a mobile ad hoc network (MANET) in battlefield for mission-critical military operations [14]. This ABS considered several perturbation factors such as noises and enemy attacks and their repercussions in the wireless communication topology of the MANET. They showed how the soldiers' collective movements positively affected to the capacity of the communication channels. Another ABS simulated the communications for the coordination of electricity distribution in smart grids [15]. The simulated outcomes showed an adequate demand response. The ABS assessed an approach about control capabilities in smart grids when there were communication constraints. Therefore, in general ABSs have proved to be useful for assessing different communication approaches.

With the advent of mobile technologies, several VR applications have been designed to assist in the diagnosis and treatment of elder people with neurodegenerative disorders. Ouellet et al. [16] recently published a study that examined the ability of a VR supermarket task to distinguish between younger and older adults, as well as individuals with and without subjective cognitive complaints. Montenegro and Argyriou [17] recently presented a game-based

application for diagnosing neurodegenerative disease. In this application, individuals complete a task similar to the Turing test in a virtual environment, and the VR application distinguished between healthy people and individuals with the neurodegenerative disease. Doniger et al. [18] recently proposed a randomized control trial for a cognitive training VR program for cognitively normal adults at high risk for a neurodegenerative disease based on family history. Their application was designed to train the capacity of remembering and executive functions (e.g., planning) by having individuals engage in a VR shopping experience in a supermarket. Participants in the proposed VR study will look for items on a grocery list and would put the items in the grocery cart. The authors plan to assess whether this app will improve cognition and cerebral blood flow in participants. In this proposed clinical trial, VR is believed to replicate the complexity of daily activities well and help train in the skills normally affected in neurodegenerative disorders.

Nevertheless, none of the aforementioned works applied fog computing for assisting and tracking elder people with neurodegenerative disorders for not overloading communications.

### 3 Materials and methods

The main material used in this research is the app for assisting and tracking elder people with neurodegenerative disorders with a fog-computing approach, which is introduced in Section 3.1. In addition, Section 3.2 describes

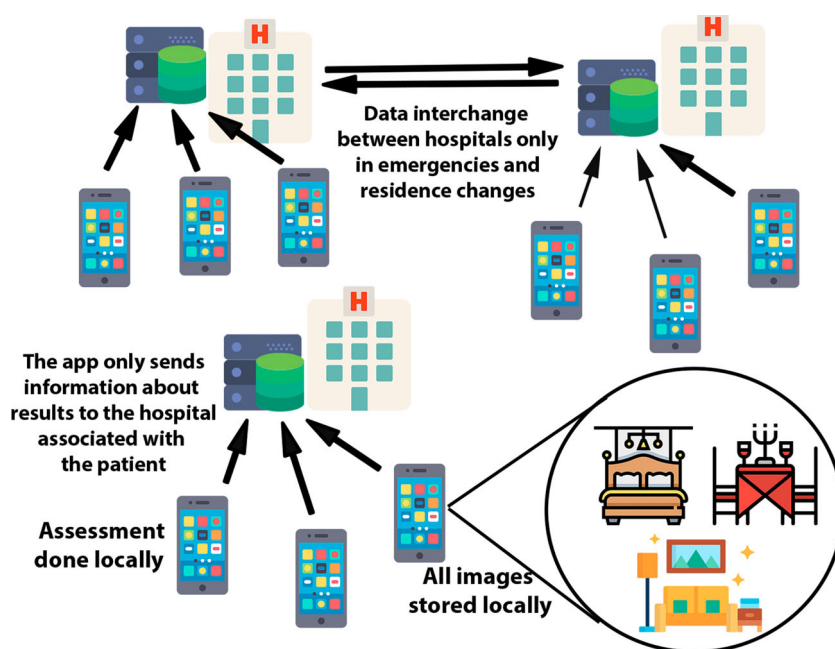
the method followed for evaluating the proposed fog-based approach with agent-based simulation.

#### 3.1 App with fog computing for elder patients with neurodegenerative disorders

Figure 1 shows the fog computing approach designed in this app. All the images and 3D scenes are stored locally in each mobile device. In this way, the transmission of images does not overload the network. The actions of patients in this app are used to evaluate some of their features. This assessment is done locally by counting the correct answers and applying the corresponding weight factors. This also saves communication bandwidth. The proposed fog-based approach only sends the final evaluation results represented as a few numbers, which is a low amount of information. Therefore, most of the processing is performed locally.

Moreover, following the principles fog computing approach, each patient is associated with their affiliated hospital. The app only sends data to the server of this hospital. In this way, the possibility that the data server of each hospital becomes a bottleneck is reduced, as the gathering of data is distributed between the different hospitals. The doctors of a hospital can directly access to the assessment results of the patients of their hospital. In the occasional cases in which a doctor needs to access to the assessment data of a patient from another hospital, then the patient's hospital sends this information to the current hospital. This should only occur in emergencies or changes of residences. In the latter case, the history data would be

**Fig. 1** Architecture of the proposed fog-based approach in the presented app



moved, and then the patient's app would be associated to their new hospital.

We developed this app in an international collaboration between University of Zaragoza and Technological University Indoamérica Guayaquil and Simón Bolívar addressing a real need detected U.S., Spain and Ecuador.

Figure 2 shows the block diagram of the functioning of the presented app. Besides the common modeling elements for actions and flow bifurcations, this diagram uses a specific notation for referring to the sending of messages. The right-bottom area of the diagram includes a legend indicating the meaning of all the used notations. It uses several scenarios for assisting elder patients with neurodegenerative diseases. For each scenario, it asks several questions or ask them to perform certain actions. Then, it asks the user to perform a task of the whole scenario. After testing all the scenarios, the app asks the user to perform a final task about some of the previous scenarios.

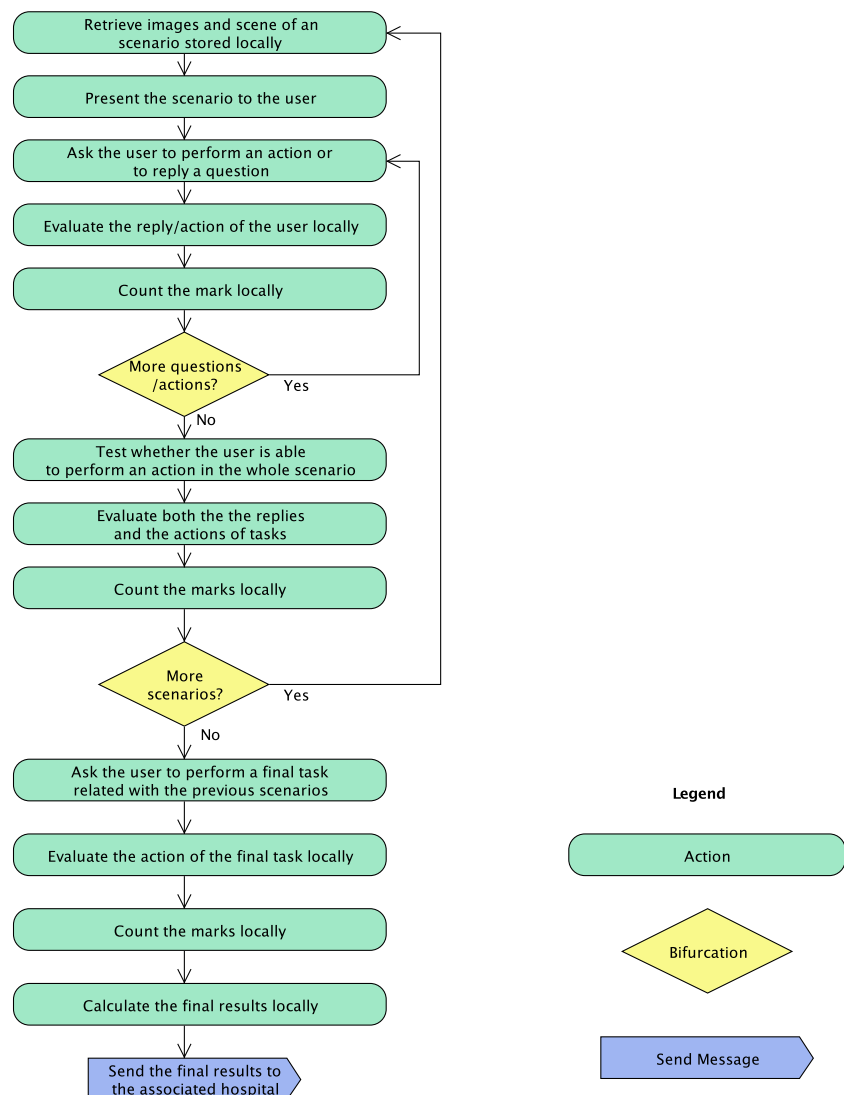
All the results are assessed locally, and only the final results are sent to the associated hospital.

The proposed app has been developed with FAMAP (a Framework for developing M-health Apps) [19], which helped us in the generic definition of test questions. The module of questionnaires was extended to allow including images in the test answer options. This app was developed with C# programming language and the Unity 3D environment.

### 3.2 Evaluation method using agent-based simulation

In order to test the performance of the proposed fog-based approach, we simulated the estimated data traffic of the app when it is widespread among some states of U.S. In order to conduct a simulation with accurate figures, we extracted the data from a official report in 2017 about one of the most

**Fig. 2** Block diagram of the proposed fog-based approach





common neurodegenerative diseases [20]. In particular, we selected all the states that had 120,000 patients of this disease or a greater number according to this report. In particular, these states with the number of patients expressed in thousands were Arizona (130), California (630), Florida (520), Georgia (140), Illinois (220), Massachusetts (120), Michigan (180), New Jersey (170), New York (390), North Carolina (160), Ohio (210), Pennsylvania (270), Texas (360) and Virginia (140).

To compare the proposed fog-based approach with alternatives, we simulated the traffic load with the same test as in the proposed app, but using other different approaches. One of these approaches used a web service in which the user just needed to access a web address with a browser. This alternative will be referred as “web service” from this point forward. The second approach was an app that stored locally the images and performed the processing, but it sent all the data results to the same central server of a particular hospital. This second alternative is referred as “alternative app” from now on.

In order to perform the simulation, we have used an ABS about the transmission of information for the different tested options. For this purpose, we have used the approach presented in TABSAOND (a technique for developing ABS apps and online tools with nondeterministic decisions) [21] for simulating the nondeterministic decisions. We selected TABSAOND because it provides a wider range of options for selecting non-deterministic decisions in comparison to other alternative ABS environments such as NetLogo and Repast Simphony. The non-deterministic decisions were appropriate for simulating people deciding when to use the app. More concretely, we used a normal distribution for simulating the distribution of people connecting to the app, which is one of the options recommended by TABSAOND. We applied a standard deviation (SD) of 0.2 over the normal distribution of probability from 0 to 1. We used a mean of 0.5 in the interval from [0, 1]. In this way random numbers homogeneously distributed in this interval were converted in values following a normal distribution, which is usually much more similar to the reality.

In order to improve the performance of the ABS, each agent simulated a group of people, as commonly done in the ABS literature (see an example in [22] in tourism domain where each agent could represent a family or a group of friends) and as recommended by PEABS (a process for developing efficient agent-based simulators) [23]. We selected PEABS instead of other general-purpose development processes such as the Scrum agile process or the iterative Rational Unified Process (RUP), because PEABS fastened the development of the ABS since it was supported with a framework for the straightforward definition of agents. We chose PEABS instead of other agent-development processes such as the

ones commonly followed in Ingenias and Prometheus methodologies, because PEABS allowed us to obtain a more efficient software product (i.e., the ABS) in terms of both response time and feasible amounts of agents.

In the ABS, each agent simulated the number of tests done by the patients of each state in each day, with the following formula:

$$t = \left( \frac{1}{\sqrt{2\pi\sigma^2}} e^{-\frac{(x-\mu)^2}{2\sigma^2}} \right) \cdot f \cdot a \cdot u \quad (1)$$

where  $\sigma$  and  $\mu$  are respectively the aforementioned SD and mean associated with the normal distribution of probabilities,  $x$  is a random number in the [0, 1] interval generated in each day a state,  $f$  is the frequency of tests per day (e.g. 0.333 if considering one test every three days in average),  $a$  is the number of patients of this disease in the corresponding state, and  $u$  is the ratio of the simulated regular users between the existing patients of this disease.

A month of 30 days was simulated considering the 14 aforementioned U.S. states. The simulations presented both the number of requests to the server (also referred as number of connections) and the data transmitted. We calculated the number of requests per test and the data transmitted for the proposed fog-based approach and each of the alternatives. The total data quantities were calculated by multiplying the number of requests by the data transmitted per request.

In this simulation evaluation, we considered that 1.0% of the patients of this disease of the 14 selected states were regular users of the app. In addition, we simulated that the frequency of users was one out of three days in average. In addition, the amount of data transferred of the proposed fog-based approach were 0.60 KB considering the assessment results, the identifier of the user, and the encryption to preserve the privacy of the user. This amount also takes into account the necessary information about the network packages such as for example the target IP address. We used the same amount for the alternative app. In order to simulate the data transmitted in the web service, we measured the information transferred considering the sum of the sizes of all the images that were necessary to transfer in each test.

We also calculated the improvement ratios about both number of connections and data transferred of the proposed fog-based approach over the two alternative approaches. We also represented the graphs of the simulation. Firstly, we compared the proposed fog-based approach with the web service, and secondly with the alternative app. The next section presents the results of these comparisons.

## 4 Results and discussions

The results of the simulations provide an estimation of the utility of the proposed fog-based approach in

terms of integrating the tracking of elder patients with neurodegenerative disorders in hospital servers without overloading the hospital communications in comparison to other alternatives. All the experiments with the proposed fog-based approach and the two alternatives have been executed with the same conditions and input parameters, which were mentioned in Section 3.2.

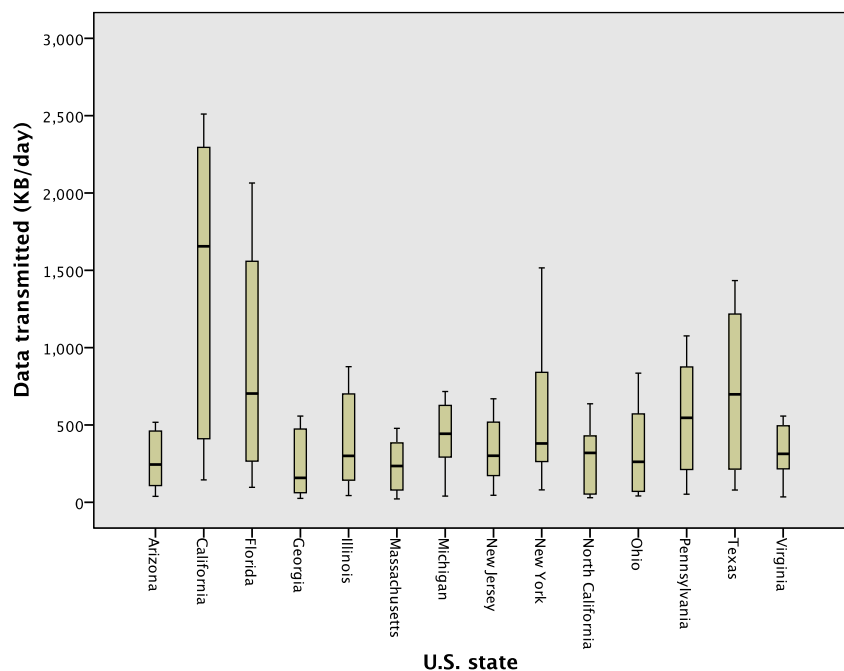
Figure 3 shows the simulation of the information transferred in the proposed fog-based approach for a month. This figure shows a boxplot that indicates the average, minimum, maximum and the division in quartiles for each U.S. state. In this case, we assumed that each of the 14 states had a hospital with a server that collected the information of the corresponding state. Figure 4 presents the simulation results of the the proposed fog-based approach about the connections to the hospital server in each state with a boxplot. The average data amount that each server needed to transfer was only 528 KB per day. The most overloaded day in the worst state was 2,472 KB, which can be considered still a very low amount. The average amount of connections was 825 connections per day, and in the worst day of the most overloaded server was 4184 connections. The amounts of transmitted data were related with the population of each state. For example, California and Florida were respectively the first and second with the most transmitted data and they were also the ones with first and second highest populations. Massachusetts and Arizona were the states with the first and second lowest populations, and also were two of the ones with the least transmitted data. The high differences of transmitted data could be possibly reduced by supporting

the data collection by more than one hospital in the states with high populations.

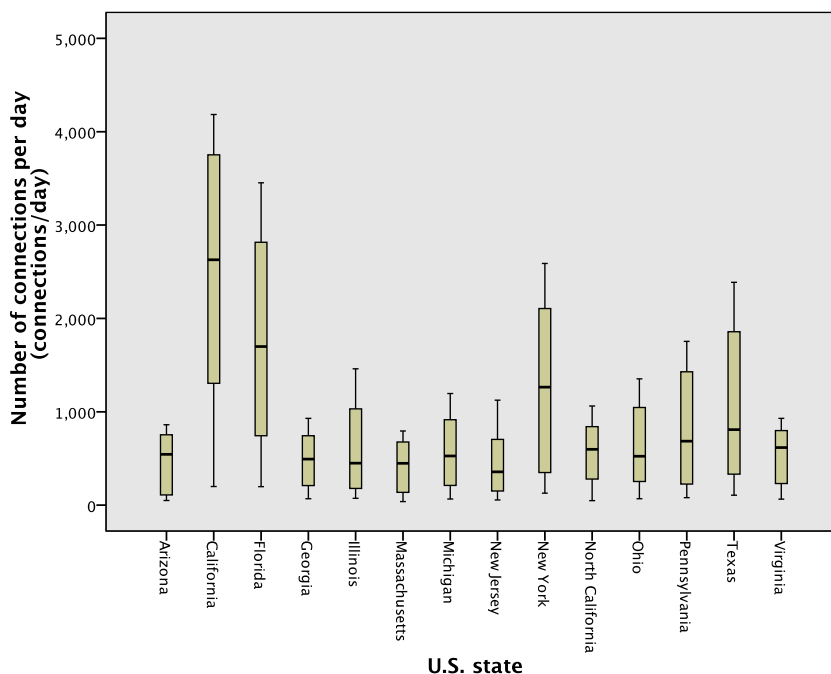
In the comparison, the first alternative was to provide the test as a web service. In this case, the result of summing all the image sizes of the test was 23.6 MB. This information needed to be transferred in every test. In addition, the web service connected to the server in every screen the user went through. More concretely, it needed 46 connections per test. In order to make a fairer comparison, we also compared the proposed fog-based approach with an alternative app, which was similar to the proposed one but without using fog computing. In particular, it also managed the images and scenes locally as well as the assessment of the scores. However, this alternative app made all the requests over the same central server with the corresponding database.

Figure 5 compares the amount of data transmitted between the patients and the server between the proposed fog-based approach and the other two alternatives. In each day of this chart, we considered the server with the highest traffic for the proposed fog-based approach. This graph uses a logarithmic scale to properly show large differences. In the web service, the average of data transmitted was 170.8 GB per day. The amount of information was more than 300,000 times than in the proposed fog-based approach. In the worst day, the server was requested to transfer 238.4 GB/day, an enormous amount that could provoke the denial of service of most test requests and slow the service down, as well as other requests in the hospital. In the alternative app, the average transmitted data was 7.06 MB/day, and the ratio was 13.80 times more than in the proposed approach considering

**Fig. 3** Simulation of data transmitted with the proposed fog-based approach



**Fig. 4** Simulation of the number of connections with the proposed fog-based approach



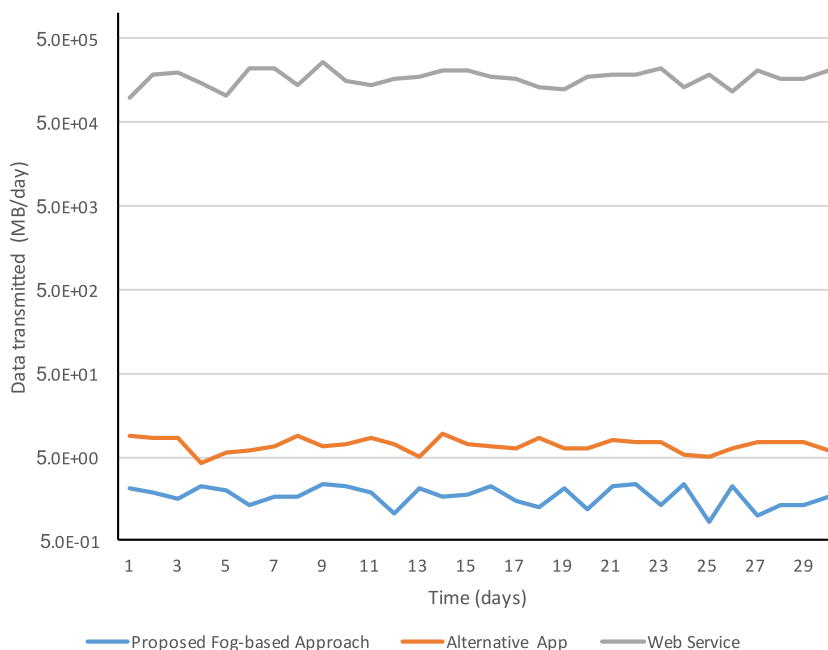
the average of the servers. This value is approximately the number of servers used in this simulation of the fog computing. Thus, one can infer that the traffic load is probably reduced approximately by a ratio about the number of servers used for the proposed fog-computing approach.

In addition, Fig. 6 compares the number of connections between the proposed fog-based approach, the web service and the alternative app. In the proposed fog-based approach, we used the maximum number of connections from all the servers. The web service needed 557,635 connections per day, which was more than 600 times more connections

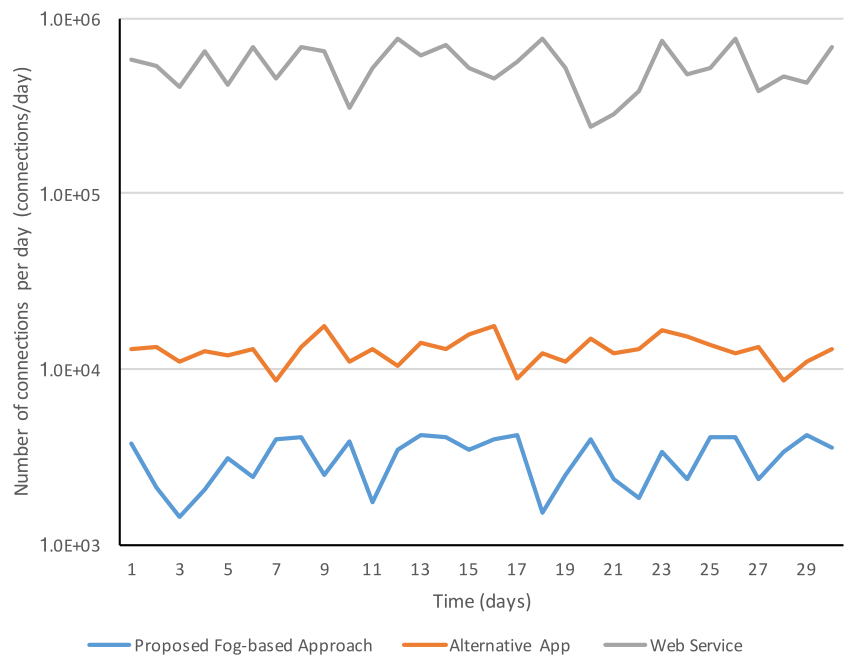
than the proposed fog-based approach. In average, the alternative app performed 12,227 connections per day, and it needed a maximum of 15,789 connections in the worst day. The proposed fog-based approach reduced 14.82 times the average connections of all servers. This number was also similar to the number of servers used in the proposed fog-based approach.

On the whole, one can observe that the proposed fog-based approach could provide an app that potentially assist and track patients with neurodegenerative disorders in the U.S. and barely interfere with the communications of

**Fig. 5** Comparison of the data transmitted between the proposed fog-based approach, the alternative app and the web service



**Fig. 6** Comparison of the number of connections per day between the proposed fog-based approach, the alternative app and the web service



hospitals by assigning the collection of data to different hospitals. The app we developed locally stores all the visual components, and also manages locally the measurement and scoring of the test, only sending the final scores that summarize all the activity of the user. Therefore, this work aligns with the principles of fog computing [8], where the storage of information and processing is mostly performed locally. It also shares the summarized information through a distributed storage system using the servers of different hospitals. In the light of the obtained results, this work recommends to integrate fog computing approach into mobile application tests for patients with neurodegenerative disorders that are rich in visual information.

It is worth mentioning that a limitation of the proposed fog-based approach is that users need to download and install the app with all its visual content. However, this communication transmission would be managed directly by the Google servers through the Google Play store, without overloading the traffic load of hospital servers.

## 5 Conclusions and future work

This work has presented a novel application for potentially assisting and tracking people with neurodegenerative diseases. This paper focuses on the application of fog computing for alleviating the use of bandwidth in hospital servers in case patients massively use the app. According to the simulated results, this app could support the assessment of patients with one of the most common neurodegenerative disease in the 14 states by only using one hospital server per state, and assuming that 1% of the patients used it regularly.

This work is planned to be extended by validating the measurement of certain features of patients with neurodegenerative diseases. We plan to conduct a pilot normative study with healthy individuals and, if appropriate based on results, a study of patients with a specific neurodegenerative disease. We aim to determine whether the measurements of our app properly correlates with validated scales. In the long-term, we may design a fog-computing approach for processing brain maps and sharing some summarized relevant information, such as the color histograms for certain regions of the brain.

**Acknowledgements** This work was performed during the research stay of the first author in the Massachusetts General Hospital and Harvard University, funded by “Dpto. de Innovación, Investigación y Universidad del Gobierno de Aragón” through the program “FEDER Aragón 2014-2020 Construyendo Europa desde Aragón” (Ref: T49\_17R). This work also acknowledges the research project “Construcción de un framework para agilizar el desarrollo de aplicaciones móviles en el ámbito de la salud” funded by University of Zaragoza and Foundation Ibercaja with grant reference JIUZ-2017-TEC-03. We also acknowledge support from “Universidad de Zaragoza”, “Fundación Bancaria Ibercaja” and “Fundación CAI” in the “Programa Ibercaja-CAI de Estancias de Investigación” with reference IT1/18.

**Publisher’s note** Springer Nature remains neutral with regard to jurisdictional claims in published maps and institutional affiliations.

## References

1. Sodhro AH, Pirbhulal S, Sangaiah AK (2018) Convergence of IoT and product lifecycle management in medical health care. *Futur Gener Comput Syst* 86:380–391

2. Farahani B, Firouzi F, Chang V, Badaroglu M, Constant N, Mankodiya K (2018) Towards fog-driven IoT eHealth: Promises and challenges of IoT in medicine and healthcare. *Futur Gener Comput Syst* 78:659–676
3. Collotta M, Pau G, Costa DG (2018) A fuzzy-based approach for energy-efficient Wi-Fi communications in dense wireless multimedia sensor networks. *Comput Netw* 134:127–139
4. Sendra S, Parra L, Lloret J, Tomás J (2018) Smart system for children's chronic illness monitoring. *Inf Fusion* 40:76–86
5. Lloret J, Parra L, Taha M, Tomás J (2017) An architecture and protocol for smart continuous eHealth monitoring using 5G. *Comput Netw* 129:340–351
6. Kao H-Y, Wei C-W, Yu M-C, Liang T-Y, Wu W-H, Wu YJ (2018) Integrating a mobile health applications for self-management to enhance telecare system. *Telematics Inform* 35(4):815–825
7. Rahmani AM, Gia TN, Negash B, Anzanpour A, Azimi I, Jiang M, Liljeberg P (2018) Exploiting smart e-health gateways at the edge of healthcare Internet-of-things: a fog computing approach. *Futur Gener Comput Syst* 78:641–658
8. Hu P, Dhelim S, Ning H, Qiu T (2017) Survey on fog computing: architecture, key technologies, applications and open issues. *J Netw Comput Appl* 98:27–42
9. Wu W, Pirbhulal S, Sangaiah AK, Mukhopadhyay SC, Li G (2018) Optimization of signal quality over comfortability of textile electrodes for ECG monitoring in fog computing based medical applications. *Futur Gener Comput Syst* 86:515–526
10. Fratu O, Pena C, Craciunescu R, Halunga S (2015) Fog computing system for monitoring Mild Dementia and COPD patients-Romanian case study. In: 2015 12th international conference on telecommunication in modern satellite, cable and broadcasting services (TELSIKS), pp 123–128. Nis, Serbia: IEEE
11. Kartsakli E, Lalos AS, Antonopoulos A, Tennina S, Di Renzo M, Alonso L, Verikoukis C (2014) A survey on M2M systems for mHealth: a wireless communications perspective. *Sensors* 14(10):18009–18052
12. Kartsakli E, Antonopoulos A, Lalos AS, Tennina S, Di Renzo M, Alonso L, Verikoukis CV (2015) Reliable MAC design for ambient assisted living: moving the coordination to the cloud. *IEEE Commun Mag* 53(1):78–86
13. Mahmoud MME, Rodrigues JJPC, Saleem K, Al-Muhtadi J, Kumar N, Korotaev V (2018) Towards energy-aware fog-enabled cloud of things for healthcare. *Comput Electr Eng* 67:58–69
14. Regragui Y, Moussa N (2016) Agent-based system simulation of wireless battlefield networks. *Comput Electr Eng* 56:313–333
15. Kilkki O, Kangasrääsio A, Nikkilä R, Alahäivälä A, Seilonen I (2014) Agent-based modeling and simulation of a smart grid: a case study of communication effects on frequency control. *Eng Appl Artif Intell* 33:91–98
16. Ouellet E, Boller B, Corriveau-Lecavalier N, Cloutier S, Belleville S (2018) The virtual shop: a new immersive virtual reality environment and scenario for the assessment of everyday memory. *J Neurosci Methods* 303:126–135
17. Montenegro JMF, Argyriou V (2017) Cognitive evaluation for the diagnosis of Alzheimer's disease based on turing test and virtual environments. *Physiol Behav* 173:42–51
18. Doniger GM, Beeri MS, Bahar-Fuchs A, Gottlieb A, Tkachov A, Kenan H, Livny A, Bahat Y, Sharon H, Ben-Gal O et al (2018) Virtual reality-based cognitive-motor training for middle-aged adults at high Alzheimer's disease risk: a randomized controlled trial. *Alzheimer's & Dementia: Translational Research & Clinical Interventions* 4:118–129
19. García-Magariño I, Bedia MG, Palacios-Navarro G (2018) FAMAP: a framework for developing m-Health Apps. In: World conference on information systems and technologies, vol 745 of advances in intelligent systems and computing, pp 850–859. Springer
20. Alzheimer's Association et al (2017) 2017 Alzheimer's disease facts and figures. *Alzheimers Dement* 13(4):325–373
21. García-Magariño I, Palacios-Navarro G, Lacuesta R (2017) TABSAOND: a technique for developing agent-based simulation apps and online tools with nondeterministic decisions. *Simul Model Pract Theory* 77:84–107
22. García-Magariño I (2015) ABSTUR: an agent-based simulator for tourist urban routes. *Expert systems with applications* 42(12):5287–5302
23. García-Magariño I, Gómez-Rodríguez A, González-Moreno JC, Palacios-Navarro G (2015) PEABS: a process for developing efficient agent-based simulators. *Eng Appl Artif Intell* 46:104–112



**Iván García-Magariño** is a lecturer and a contributor to the GRASIA research group at the Complutense University of Madrid. Prior to commencing this position in 2018, he was a PhD assistant professor in University of Zaragoza (2014–2018), and before he was a lecturer at the Madrid Open University (2010–2014). Iván was awarded his Ph.D. in Computer Science Engineering from the Complutense University of Madrid in 2009, and was a recipient of an FPI

scholarship from 2006 to 2010. His main research interests include agent-based simulators, multi-agent systems, and agent-oriented software engineering. Among journals, book chapters, conferences and workshops, he has over 100 publications (over 45 in journals with ISI Thomson JCR). He actively collaborates with the EduQTech research group from the University of Zaragoza on m-health projects, the HCI Lab from the University of Udine (Italy) on human-computer interaction projects, Institute of Technology Blanchardstown (Ireland) on datamining projects, and the Multicultural Alzheimer Prevention Program (MAPP) of Massachusetts General Hospital and Harvard University (US) on m-health projects. He is editor in the *Heliyon* journal of Elsevier publisher, and he is guest editor in several special issues in journals with impact factor.



**José Varela-Aldas** (1990) is an Industrial Engineer in Automation Processes from the Universidad Técnica de Ambato (2014) and has a Master's degree in Control Systems and Industrial Automation from the Escuela Politécnica de Chimborazo - Ecuador (2016). He is currently a PhD candidate in Electronic Engineering from the University of Zaragoza - Spain. He was a full-time professor at the Universidad de la Fuerzas Armadas ESPE,

where he taught the following subjects: General Electronics, Electrical Measures, Industrial Control and Power Electronics. He is currently a full professor at the Universidad Tecnológica Indoamérica in the following subjects: Robotics, Electrical Engineering and Electricity and Industrial Electronics. His areas of interest are: control systems, robotics, virtual reality and augmented reality.


**Guillermo Palacios-Navarro** was born in Zaragoza (Spain) in 1972. He received a B.S., M.S. ('96) and Ph.D. ('09) degrees in Telecommunication Engineering from University of Zaragoza - Spain. Following experience as a software engineer in several firms, he joined Teruel Polytechnic School of Engineering in 1998. Since then, he has been with the department of Electronic Engineering and Communications, University of Zaragoza, where he is currently an Associate Professor. Dr. Palacios is the recipient of a "Prometeo Researching Grant" awarded by the Ecuadorian government. He has also been a visiting faculty in the Newman Laboratory for Biomechanics and Human Rehabilitation at the Massachusetts Institute of Technology (MIT). Concerning researching activities, he has authored and co-authored several book chapters and numerous articles in scientific journals and international conferences. He also has coordinated several R&D projects and has also participated as a member of scientific committees in different workshops and conferences. Dr. Palacios' research interests include virtual rehabilitation techniques applied to the recovery of neurodegenerative disorders human computer interfaces and any kind of information technology designs to improve quality in engineering education.



**Jaime Lloret** (jlloret@dcom.upv.es) received his B.Sc.+M.Sc. in Physics in 1997, his B.Sc.+M.Sc. in electronic Engineering in 2003 and his Ph.D. in telecommunication engineering (Dr. Ing.) in 2006. He is a Cisco Certified Network Professional Instructor. He worked as a network designer and administrator in several enterprises. He is currently Associate Professor in the Polytechnic University of Valencia. He is the Chair of the Integrated Management

Coastal Research Institute (IGIC) and he is the head of the "Active and collaborative techniques and use of technologic resources in the education (EITACURTE)" Innovation Group. He is the director of the University Diploma "Redes y Comunicaciones de Ordenadores" and he has been the director of the University Master "Digital Post Production" for the term 2012-2016. He was Vice-chair for the Europe/Africa Region of Cognitive Networks Technical Committee (IEEE Communications Society) for the term 2010-2012 and Vice-chair of the Internet Technical Committee (IEEE Communications Society and Internet society) for the term 2011-2013. He has been Internet Technical Committee chair (IEEE Communications Society and Internet society) for the term 2013-2015. He has authored 22 book chapters and has more than 450 research papers published in national and international conferences, international journals (more than 200 with ISI Thomson JCR). He has been the co-editor of 40 conference proceedings and guest editor of several international books and journals. He is editor-in-chief of the "Ad Hoc and Sensor Wireless Networks" (with ISI Thomson Impact Factor), the international journal "Networks Protocols and Algorithms", and the International Journal of Multimedia Communications. Moreover, he is Associate Editor-in-Chief of "Sensors" in the Section sensor Networks, he is advisory board member of the "International Journal of Distributed Sensor Networks" (both with ISI Thomson Impact factor), and he is IARIA Journals Board Chair (8 Journals). Furthermore, he is (or has been) associate editor of 46 international journals (16 of them with ISI Thomson Impact Factor). He has been involved in more than 450 Program committees of international conferences, and more than 150 organization and steering committees. He has led many local, regional, national and European projects. He is currently the chair of the Working Group of the Standard IEEE 1907.1. Since 2016 he is the Spanish researcher with highest h-index in the TELECOMMUNICATIONS journal list according to Clarivate Analytics Ranking. He has been general chair (or co-chair) of 45 International workshops and conferences (chairman of SENSORCOMM 2007, UBICOMM 2008, ICNS 2009, ICWMC 2010, eKNOW 2012, SERVICE COMPUTATION 2013, COGNITIVE 2013, ADAPTIVE 2013, 12th AICT 2016, 11th ICIMP 2016, 3rd GREENETS 2016, 13th IWCMC 2017, 10th WMNC 2017, 18th ICN 2019, 14th ICDT 2019, 12th CTRQ 2019, and GCElecEng 2019, and co-chairman of ICAS 2009, INTERNET 2010, MARSS 2011, IEEE MASS 2011, SCPA 2011, ICDS 2012, 2nd IEEE SCPA 2012, GreeNets 2012, 3rd IEEE SCPA 2013, SSPA 2013, AdHocNow 2014, MARSS 2014, SSPA 2014, IEEE CCAN 2015, 4th IEEE SCPA 2015, IEEE SCAN 2015, ICACCI 2015, SDRANCAN 2015, FMEC 2016, 2nd FMEC 2017, 5th SCPA 2017, XIII JITEL 2017, 3rd SDS 2018, 5th IoTSMS 2018, 4th FMEC 2019, and 10th International Symposium on Ambient Intelligence, and local chair of MIC-WCMC 2013 and IEEE Sensors 2014). He is IEEE Senior, ACM Senior and IARIA Fellow.

## Affiliations

Iván García-Magariño<sup>1,2</sup> · José Varela-Aldas<sup>3</sup> · Guillermo Palacios-Navarro<sup>4</sup> · Jaime Lloret<sup>5</sup> 

Iván García-Magariño  
igarciam@ucm.es

José Varela-Aldas  
josevarela@uti.edu.ec

Guillermo Palacios-Navarro  
guillermo.palacios@unizar.es

- <sup>1</sup> Department of Software Engineering and Artificial Intelligence, Complutense University of Madrid, 28040 Madrid, Spain
- <sup>2</sup> Instituto de Investigación Sanitaria Aragón, University of Zaragoza, Zaragoza, Spain
- <sup>3</sup> Facultad de Ingeniería y Tecnologías de la Información y Comunicación, Universidad Tecnológica Indoamérica, EC180103 Ambato, Ecuador
- <sup>4</sup> Department of Electronic Engineering and Communications, University of Zaragoza, 44003 Teruel, Spain
- <sup>5</sup> Integrated Management Coastal Research Institute, Universitat Politècnica de València, 46022 València, Spain

## **II. Immersive virtual reality app for mild cognitive impairment**



# Immersive Virtual Reality App for Mild Cognitive Impairment

José Varela-Aldás<sup>1a,1b</sup>, Guillermo Palacios-Navarro<sup>2</sup>, Iván García-Magariño<sup>3</sup>

josevarela@uti.edu.ec, guillermo.palacios@unizar.es, igarciam@ucm.es

<sup>1a</sup> Universidad Tecnológica Indoamérica, 180103, Ambato, Ecuador.

<sup>1b,2</sup> University of Zaragoza, 44003, Teruel, Spain.

<sup>3</sup> Complutense University of Madrid, 28040, Madrid, Spain

**Pages:278–290**

**Abstract:** A characteristic symptom of neurodegenerative diseases is the deterioration of the memory. These problems usually worsen with the progression of the disease, being the cognitive rehabilitation an important tool in order to slow down the progress of the disease in the patient. This work presents the development of a mobile virtual reality application through a serious game to boost the memory by solving mazes in three levels of difficulty. The application uses the Gear VR glasses to provide the user with an immersive experience. The results present the proposed application, showing the components of the virtual environment.

**Keywords:** virtual reality; mobile application; immersive environment; memory deterioration.

## 1. Introduction

Memory loss is the main symptom of multiple neurodegenerative diseases (Parkinson's, Alzheimer's, sclerosis, and so on). These diseases currently have no cure, but there are several treatments to slow down their progress, allowing to prolong life and improve the patient's living conditions. The traditional treatments include brushing up on activities and exercising the brain, for which the assistance of qualified personnel and continuous rehabilitation sections are required, however, the use of technology has changed the methodology used to stay mentally sharp (Wang & Holsinger, 2018).

With the rapid development of new information and communication technologies, currently, new prospects for assistance in the healthcare sector have been inserted. Specifically in assisting cognitive rehabilitation therapies, virtual reality (VR) environments have been developed in a way which allows the patient to train their memory in serious game applications with multiple alternatives of use. At a basic level, virtual environments are presented on screens and manipulated using external tactile inputs, but at an immersive level, the system has head-mounted displays (HMDs), which allow the user to interact realistically with the game (Chicaiza et al., 2018). However, an inherent limitation of this technology is the high costs of specialized equipment which rehabilitation would require.

A sector with more technological improvements are the Smartphones, which currently have more processing features and improved accuracy in their sensors than ever before, so it is not a problem to implement VR applications in these devices, and with the support of low-cost components, smartphones can be used as portable HMDs, where the device's screen shows the virtual environment to the user (Zhang & Ho, 2017). This technological combination facilitates the use of cognitive virtual rehabilitation in patients with neurodegenerative diseases, without the need of leaving their home.

In this work, a serious game of virtual reality is presented to train the memory of patients with neurodegenerative diseases in its early stages. The main purpose of the proposed application is to generate a computer created environment for the patient to solve a labyrinth in three degrees of difficulty, previously reviewing the possible solutions from an aerial view. This application is implemented on a mobile device, where Samsung Gear VRs are used to obtain the immersion effect; an operation evaluation is performed and a SUS usability test is applied to the user. This paper is structured as follows: In Section 2, a review of the state of the art is given; In Section 3, the design and implementation of the proposed application are described. In Section 4, the experimental results are described. Finally, in Section 5, conclusions are established and future work is outlined.

## 2. State of the art

Currently, virtual reality is a widely applied tool in multiple areas. In this context, its characteristics have been studied and the user's reactions have been compared with respect to real experience. (Raptis, Fidas & Avouris, 2018) studies the effects of a fictitious reality in tourism and recognizes its advantages, the results support the importance of these systems; (Ding, Zhou & Fung, 2018) finds that enjoying cinema in VR exceeds typical 2D entertainment. On the other hand, a field which makes the most of virtualization technology is health, developing systems with virtual elements in the rehabilitation of various diseases. (Lv et al., 2017) designs a serious game for the rehabilitation of Dysphonia, and tests with experts and patients support the use of the voice game; (Arango, Mazo & Peñalpalacio, 2013) implements an augmented reality system to treat phantom limb syndrome; and (Wang & Reid, 2013) uses a VR application to improve contextual processing in children with autism where cognitive flexibility was demonstrated.

A specific case of the use of information technologies in health is the treatment of neurodegenerative diseases, for which applications have been developed which slow down the decline in memory (Jonsdottir et al., 2018; Zanier et al., 2018), show that these symptoms are found in patients with diseases such as Alzheimer's, multiple sclerosis, Parkinson's, Huntington's, and so on, but they also manifest due to aging in older adults (Chicaiza et al., 2018) demonstrates experimental results of a complex system of virtual reality implemented which favors the exercise of memory. The use of these VR applications is usually accompanied by an examiner who monitors the progression of the disease, but in cases of mild cognitive impairment the user might perform their virtual rehabilitation from home, facilitating the treatment of the disease.

The insertion of technological systems to support rehabilitation usually involves high costs, because they require up-to-date technology and specialized software, being the use of mobile devices a solution to this problem; (Razo Salas, Vázquez Reyes & Solís

Robles, 2016) uses the screen of a mobile device to visualize the images in an endoscopic process, results which are approved by a specialist; (Green et al., 2018) proposes a mobile application to assist in the providing of anesthesia; similarly, cognitive problems can be supported by mobile applications, (Yasini & Marchand, 2016) analyses the use of a smartphone in the cognitive stimulation of older adults and the results indicate that users do not get tired of playing with their tablet over time and that the average daily time spent on games increases significantly. Furthermore, combining mobile devices with virtual reality, involves several elements for its operation; (Zhang & Ho, 2017) analyses the use of immersive mobile applications for the rehabilitation of addictions through a Smartphone and an HMD device, concluding the benefits of the appropriate use of mobile virtual reality in this area of health.

### 3. Proposed system

The proposed structure involves several components to support the virtual rehabilitation system. To facilitate the usability of the system, the proposal has been designed considering the installation costs, the requirements of the workplace, and the difficulty of operation. The system consists of a virtual reality environment which allows exercising the memory of the patient in different levels of difficulty. In order to achieve a certain level of immersion, portable HMDs are used to support the visualization of the application from virtual reality glasses for Smartphone, where the environment is controlled by the user from a manual command. The components of the system are described in the following sentences.

Figure 1 presents the proposed system for the cognitive rehabilitation of patients with memory impairment. At this point, the user uses two devices to interact with the rehabilitation system: Gear VR headset is used to achieve the player’s immersion in the virtual environment as an HMD device, allowing the user to look at the environment and control the visualization through the movements of the head and the hand controller. This allows the patient to navigate in the virtual environment and select the options of the application. On the other hand, the Smartphone is the most important element of the system because it performs the processing of the aforementioned devices, the virtual reality application processes, the data corresponding to the Gear VR, and the hand controller.

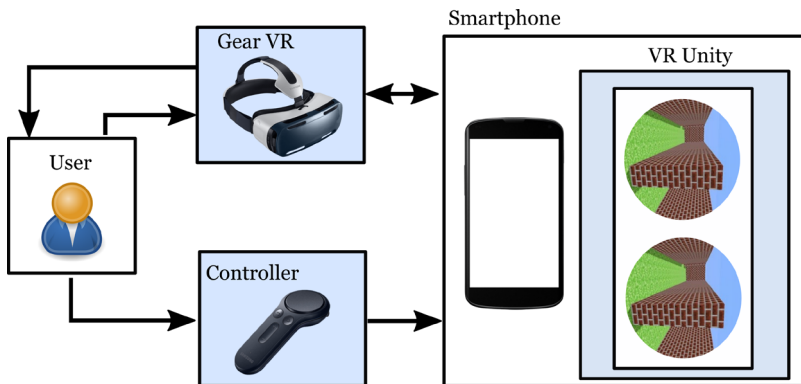


Figure 1 – Mobile virtual reality system

The application of the virtual environment allows the patient to exercise their memory by solving mazes in 3 levels of difficulty. Figure 2 shows a summary of the proposed application, where the main menu contains the access button to the application, then the patient must perform the user identification to load their previous data. The secondary menu allows the user to select the difficulty level and display the previous ratings using the stored data. Within the game, the user can firstly see an aerial view to perform the selected memory exercise, reviewing the possible exit routes of the maze and then he/she is positioned somewhere in the maze. The next instruction is to try to get out of the maze, reminding the shapes previously displayed. Once achieved the objective, the application presents the results of the experiment and this information is stored in a database; the user can continue with the game experiments or exit if desired. For a better understanding of the components of the application, the following section describes the elements of the Virtual Reality application.

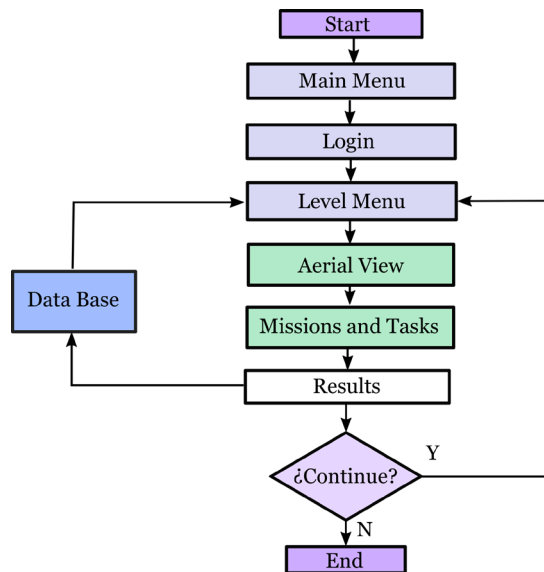


Figure 2 – Proposed application

#### 4. Development of the application

The virtual reality application has been developed in unity due to the flexibility in the selection of hardware, allowing to install the application on a Smartphone to use it as an HMD device. Figure 3 presents the components of the virtual system, where the three main components can be differentiated: The Game Objects, which includes all the elements that make up the virtual environment; the virtual reality, which coordinates between the virtual environment and the devices for interaction with the user; and the database, which stores the information related to the features of the game and the results of the users.

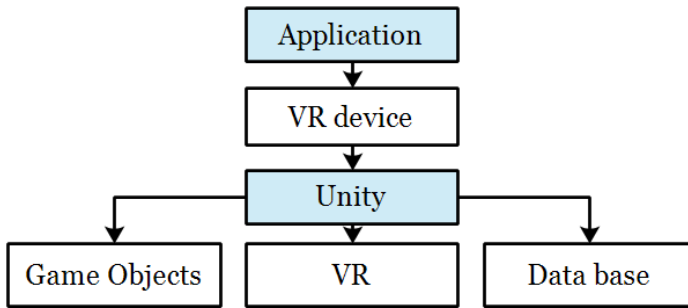


Figure 3 – Application components

**4.1. Virtual environment**

The virtual environment is made up of three-dimensional elements which have been developed in different support platforms. Figure 4 shows the three stages for the creation of virtual objects.

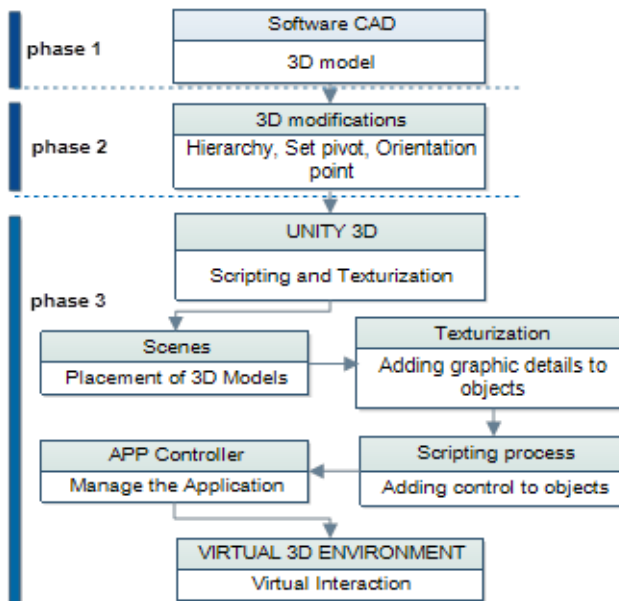


Figure 4 – Development of the virtual environment

In a first phase it is necessary to build the solid objects in a CAD software which allows developing the 3D models; later, these models require changes in their characteristics, such as the creation of hierarchies and the establishment of points of orientation. Finally, these files are exported to unity to be textured and used in virtual reality scripts. The new objects placed in unity need modifications to be used in the virtual reality application,

starting with the construction of scenes through the location of the exported models. Additionally, details are added to the graphics by applying textures to the objects, these components are controlled by scripts to fulfill their function in the virtual reality application. These functionalities are evaluated and corrected in a process of validation of scripts, finally, the user interface for user interaction with virtual scenes is developed.

The serious game is developed to exercise short-term memory in the user. This rehabilitation tool allows the user to memorize details of the environment and to provide ways to move in computer-generated environments. The main activity is to solve a maze which is initially visualized from an aerial view, allowing the user to find an exit route. Once inside the maze, geometric shapes are presented in order to increase the difficulty of the application. The exercise can be done in three levels of difficulty, as shown in Figure 5; the basic level requires finding the exit in a small maze and counting the number of geometric shapes which appear in the path; the medium level consists of solving a moderately complicated maze and memorizing the number of geometric shapes, each shape with a specific color; and the advanced level requires getting out a complex maze, remembering each of the geometric shapes with their respective color.

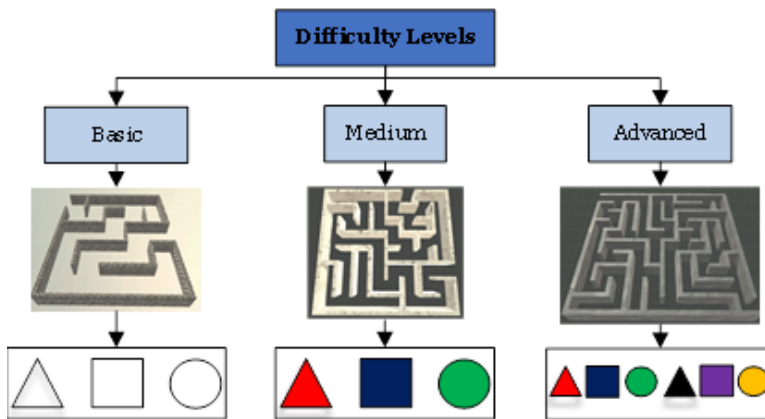


Figure 5 – Levels of difficulty

## 4.2. Virtual reality features

The virtual reality feature is integrated by the locomotion of the player, the interaction of the user with the virtual environment, and the user interface.

### *Locomotion*

The movements on the virtual environment are developed using the smooth artificial locomotion technique which allows the user to move slightly in the desired directions by moving the thumb on the touchpad of the controller, as shown in Figure 6. This technique of locomotion is useful to move in small spaces and inserts realism to the displacements and avoids confusions of spatial orientation as opposed to the teleport method. The allowed movements are a linear forward and backward speed and angular

velocity with fixed rotation step to prevent motion sickness, both movement options controlled from the controller's touchpad.

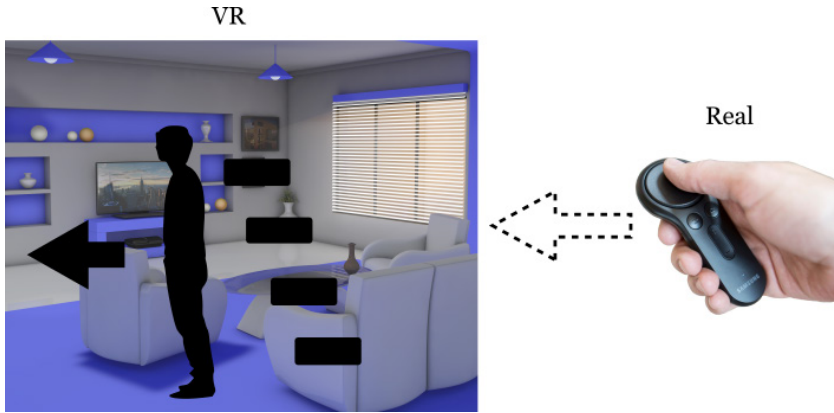


Figure 6 – Smooth artificial locomotion

*Interaction*

For the user to interact with the virtual environment in an immersive way, the Smartphone manages the images to be viewed according to the user's head movement, this is possible due to the smartphone's inertial sensors, achieving greater realism and comfort in the VR. The Gear VR controller also includes an inertial measurement unit, which allows addressing a pointer in the virtual environment with 2 degrees of freedom, as shown in Figure 7. In addition, the selection of options is executed by a trigger button.

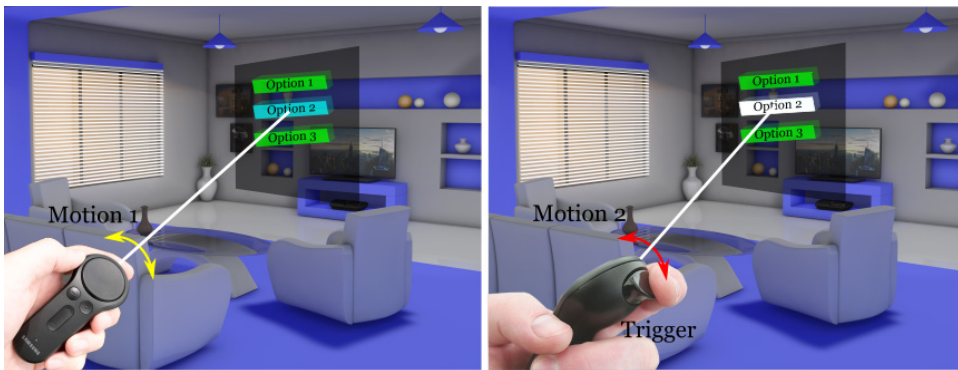


Figure 7 –Virtual interaction

*User Interface*

The VR application has three interface panels to choose, Figure 8 lists these components. Initially, the user must log in to the system using a username and password, this data allows retrieving the information of the user profile and remember the achievements. The

next panel is used to select the level of difficulty to solve, loading the system according to the user’s selection. Finally, the results panel presents the scores reached at the end of each cycle.

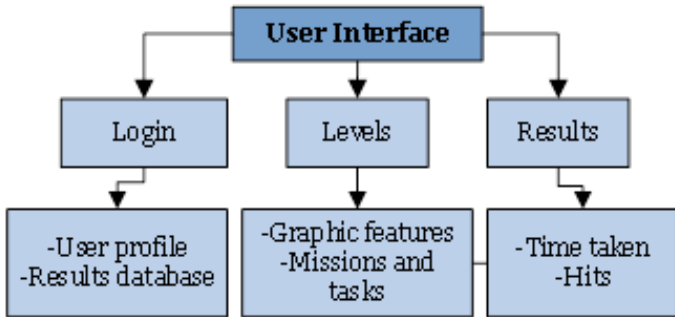


Figure 8 – User interface components

### 4.3.Database

The VR application has a database which stores the information in three blocks, as shown in Figure 9. The user block saves the data for access to the application and the profile of the users registered in the system. The information of the missions contains the mazes for the three levels of difficulty, stores the geometric shapes, the tasks to be done in the path of the mazes, and finally the results, where the time histories and successes obtained at the end of each game are recorded.

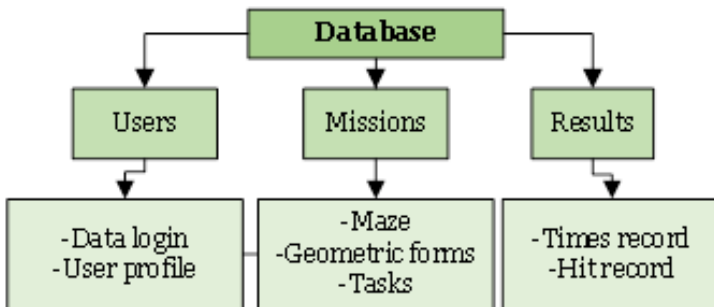


Figure 9 – Database

## 5. Experimental results

For the experimentation of the immersive virtual reality mobile application, an example is presented in this Section. For this, a Galaxy S8+ Smartphone and the Gear VR headset with its controller has been used, where Figure 10 shows the experiments carried out



with a male user of 60 years of age. In this example, the user is healthy but presents some memory difficulties produced by age.



Figure 10 – Experiments on GearVR device

When started the game, the user must log in with their email and password, as shown in Figure 11. In case of not being registered, a new user profile must be created with the personal data.

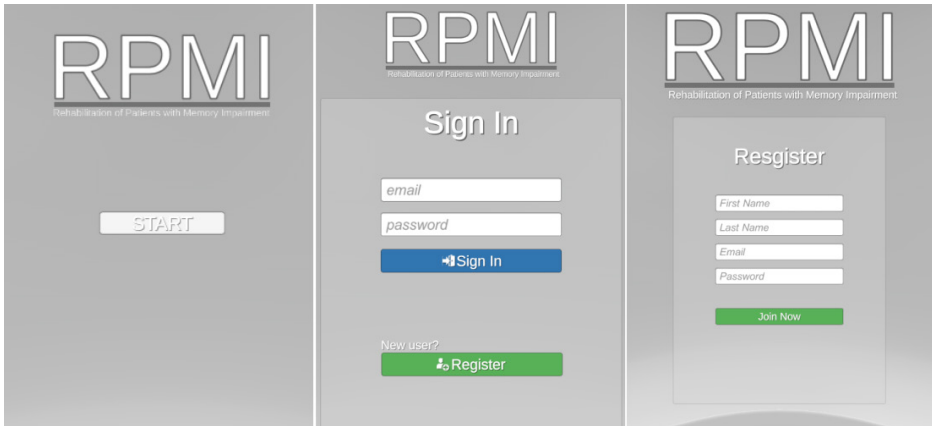


Figure 11 – Login to the application

Then choose the level of difficulty to be evaluated. Figure 12 presents the three levels to solve in maze.

Figure 13 shows the first view of the maze to be solved from an aerial view. This allows the user to analyze the exit routes for later move inside the maze, and then he/she is located at the entrance of the route.

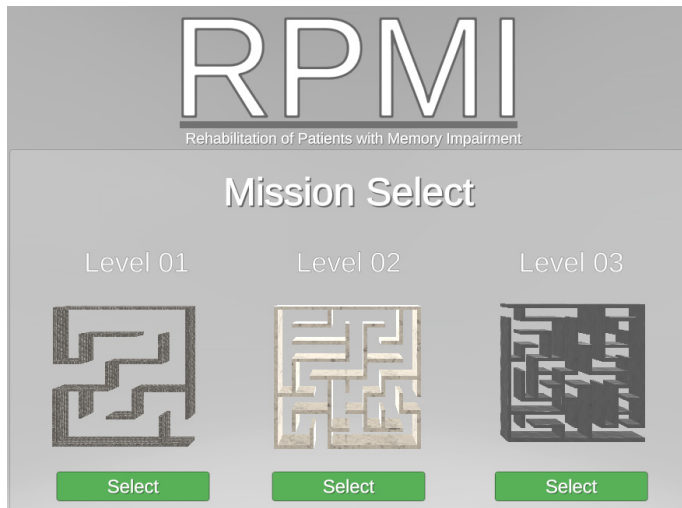


Figure 12 – Interface to choose the level of difficulty



Figure 13 – Starting the game

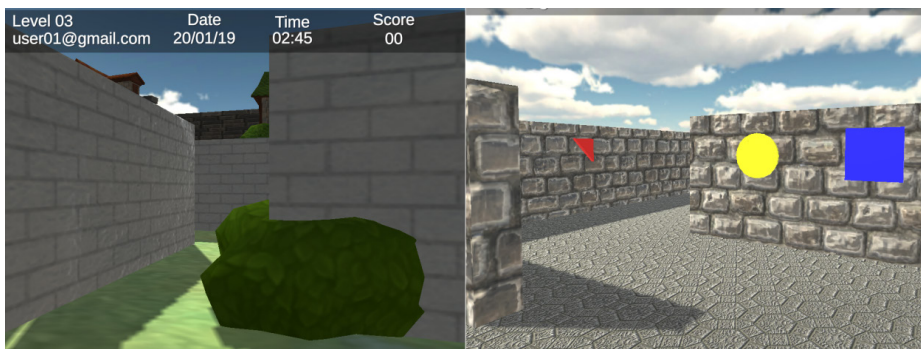


Figure 14 – Inside the maze

Once inside the maze, the users must move in the directions which they consider correct using the touchpad of the Gear VR controller. In the path, the user will find geometric figures according to the level selections, see Figure 14.

At the end of the maze, a questionnaire appears which records the geometric shapes remembered and assigns a score according to the user’s responses. These data are stored and summarized in the results screen of Figure 15, where the user registers 5 days of experiments, he/she have solved the maze in the three levels of difficulty, and an improvement in the score reached is observed, as well as in the time taken to find the exit.

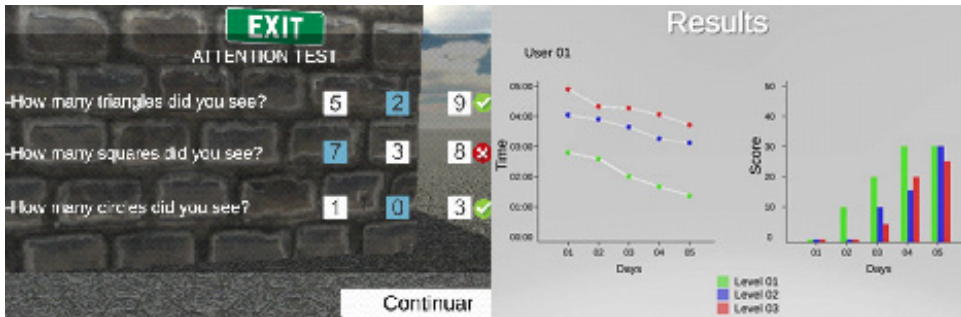


Figure 15 – Results

Nº	Questions	Score	Operation
1	<i>I think I would like to use this system frequently</i>	4	4-1=3
2	<b><i>I find this system unnecessarily complex</i></b>	1	5-1=4
3	<i>I think the system is easy to use</i>	5	5-1=4
4	<b><i>I think you would need technical support to make use of the system</i></b>	1	5-1=4
5	<i>I find the various functions of the system quite well integrated</i>	4	4-1=3
6	<b><i>I have found too much inconsistency in this system</i></b>	1	5-1=4
7	<i>I think most people would learn to make use of the system quickly</i>	5	5-1=4
8	<b><i>I found the system quite uncomfortable to use</i></b>	3	5-3=2
9	<i>I have felt very safe using the system</i>	3	3-1=2
10	<b><i>I would need to learn a lot of things before I can manage the system</i></b>	1	5-1=4
	TOTAL		34
	<b>Global Value</b>		<b>85</b>

Table 1 – Survey results

Additionally, Literature of (Sauro & Lewis, 2011) and (Shaheen & Rehman, 2018) is used to determine the usability of the application by means of a SUS test. The score is determined by the sum of the values of each item, said score will have a range of 0 to 4. For numbers 1, 3, 5, 7 and 9, the operation is the score given minus 1; for items 2, 4, 6, 8 and 10, the operation is 5 minus the score. The total sum of the results is multiplied by 2.5 obtaining the overall value of the SUS. The final result is obtained in the range of 0 to 100. For the answers indicated in the questions, Table 1 is obtained.

The results of this example indicate that the application works correctly and provides a user-friendly experience in the test performed, however, it also shows an opportunity for improvement in some questions of the SUS, especially in providing security to user.

## 6. Conclusions

Modern mobile devices support immersive virtual reality applications, this because of their high throughput and multiple sensors. Specifically, cognitive virtual rehabilitation allows the user to treat the progress of a neurodegenerative disease in its early stages. This implies which mild memory impairment can be treated by memory exercises in virtual environments.

This application supports the user to train their memory through a maze-solving game in an immersive way using the Gear VR, allowing the user to remember an aerial view of the routes and to practice the spatial orientation in the virtual environment. In addition, the patient might memorize geometric shapes which must be remembered at the end of the maze. The results show that the user performs many successful tests with improvements in their memory retention scores, and an acceptable usability score.

Future work is intended to include more experiences in the process of navigate through the maze and include biometric sensors in the user to monitor the patient's vital and cognitive states.

## References




- Arango, J. E., Mazo, J. C., & Peñapalacio, A. (2013). Sistema para Rehabilitación del Síndrome del Miembro Fantasma utilizando Interfaz Cerebro- Computador y Realidad Aumentada. *RISTI - Revista Ibérica de Sistemas e Tecnologias de Informação*, 93–106. DOI: 10.4304/risti.11.93-106
- Chicaiza, F. A., Lema-Cerda, L., V. M. Á., Andaluz, V. H., Varela-Aldás, J., Palacios-Navarro, G., & García-Magariño, I. (2018). Virtual Reality-Based Memory Assistant for the Elderly. In *Lecture Notes in Computer Science* (pp. 269–284).
- Ding, N., Zhou, W., & Fung, A. Y. H. (2018). Emotional effect of Cinematic VR compared with traditional 2D film. *Telematics and Informatics*, (April). DOI: 10.1016/j.tele.2018.04.003
- Green, M. S., Mathew, J. J., Venkatesh, A. G., & Green, P. (2018). Utilization of Smartphone Applications by Anesthesia Providers. *Anesthesiology Research and Practice*, 2018, 5–9.

- Jonsdottir, J., Bertoni, R., Lawo, M., Montesano, A., Bowman, T., & Gabrielli, S. (2018). Serious games for arm rehabilitation of persons with multiple sclerosis. A randomized controlled pilot study. *Multiple Sclerosis and Related Disorders*, 19, 25–29. DOI: 10.1016/j.msard.2017.10.010
- Lv, Z., Esteve, C., Chirivella, J., & Gagliardo, P. (2017). rehabilitation Serious Game Based Personalised Healthcare System for Dysphonia Rehabilitation. *Pervasive and Mobile Computing*. DOI: 10.1016/j.pmcj.2017.04.006
- Raptis, G. E., Fidas, C., & Avouris, N. (2018). Effects of mixed-reality on players' behaviour and immersion in a cultural tourism game: A cognitive processing perspective. *International Journal of Human - Computer Studies*. DOI: 10.1016/j.ijhcs.2018.02.003
- Razo Salas, M. A., Vázquez Reyes, S., & Solís Robles, R. (2016). Mejoras del proceso endoscópico usando aplicaciones móviles. *RISTI - Revista Ibérica de Sistemas e Tecnologías de Informação*, 115–127. DOI: 10.17013/risti.17.115
- Sauro, J., & Lewis, J. R. (2011). When Designing Usability Questionnaires , Does It Hurt to Be Positive ? In *Proceedings of the SIGCHI Conference on Human Factors in Computing Systems* (pp. 2215–2223).
- Shaheen, R., & Rehman, M. (2018). Evaluating Health Information Apps on Real Life Smart Phone Use. In *ACM International Conference Proceeding Series 30*.
- Wang, A. R., & Holsinger, R. M. D. (2018). Exercise-Induced Brain-Derived Neurotrophic Factor Expression: Therapeutic Implications for Alzheimer's Dementia. *Ageing Research Reviews*, 48, 109–121. DOI: 10.1016/j.arr.2018.10.002
- Wang, M., & Reid, D. (2013). Using the Virtual Reality-Cognitive Rehabilitation Approach to Improve Contextual Processing in Children with Autism. *The Scientific World Journal*, 2013.
- Yasini, M., & Marchand, G. (2016). Adoption and Use of a Mobile Health Application in Older Adults for Cognitive Stimulation. *Studies in Health Technology and Informatics*, 13–17. DOI: 10.3233/978-1-61499-633-0-13
- Zanier, E. R., Zoerle, T., Lernia, D. Di, & Riva, G. (2018). Virtual Reality for Traumatic Brain Injury. *Frontiers in Neurology*, 9(May), 1–4. DOI: 10.3389/fneur.2018.00345
- Zhang, M. W. B., & Ho, R. C. M. . (2017). Smartphone applications for immersive virtual reality therapy for internet addiction and internet gaming disorder. *Technology and Health Care*, 1, 367–372. DOI: 10.3233/THC-1601282

### **III. Head-mounted display-based application for cognitive training**

Article

# Head-Mounted Display-Based Application for Cognitive Training

José Varela-Aldás <sup>1,2</sup>, Guillermo Palacios-Navarro <sup>1,\*</sup>, Rebecca Amariglio <sup>3,4</sup>  
and Iván García-Magariño <sup>5</sup>

<sup>1</sup> Department of Electronic Engineering and Communications, University of Zaragoza, 44003 Teruel, Spain; josevarela@uti.edu.ec

<sup>2</sup> Facultad de Ingeniería y Tecnologías de la Información y la Comunicación, Universidad Tecnológica Indoamérica, Ambato 180103, Ecuador

<sup>3</sup> Medical School, Harvard University, Boston, MA 02115, USA; ramariglio@mgh.harvard.edu

<sup>4</sup> Massachusetts General Hospital, Boston, MA 02114, USA

<sup>5</sup> Department of Software Engineering and Artificial Intelligence, Complutense University of Madrid, 28040 Madrid, Spain; igarciam@ucm.es

\* Correspondence: guillermo.palacios@unizar.es

Received: 21 October 2020; Accepted: 12 November 2020; Published: 17 November 2020



**Abstract:** Virtual Reality (VR) has had significant advances in rehabilitation, due to the gamification of cognitive activities that facilitate treatment. On the other hand, Immersive Virtual Reality (IVR) produces outstanding results due to the interactive features with the user. This work introduces a VR application for memory rehabilitation by walking through a maze and using the Oculus Go head-mounted display (HMD) technology. The mechanics of the game require memorizing geometric shapes while the player progresses in two modes, autonomous or manual, with two levels of difficulty depending on the number of elements to remember. The application is developed in the Unity 3D video game engine considering the optimization of computational resources to improve the performance in the processing and maintaining adequate benefits for the user, while the generated data is stored and sent to a remote server. The maze task was assessed with 29 subjects in a controlled environment. The obtained results show a significant correlation between participants' response accuracy in both the maze task and a face-pair test. Thus, the proposed task is able to perform memory assessments.

**Keywords:** cognitive rehabilitation; head-mounted display; immersive virtual reality; memory assessment; Oculus Go; serious game; wearable system

## 1. Introduction

Reality refers to the physical world in which the human being develops and lives with other elements, using all his senses. Although the activities carried out by a user still require their presence, technological means of communication have been designed that have changed the way to interact with the environment [1,2]. With the advancement of science, extended reality (XR) systems have been developed that allow reproducing environments, people, and objects with high fidelity using a computer [3,4]. This term includes virtual reality (VR), augmented reality (AR), and mixed reality (MR) [5]. VR refers to complete three-dimensional virtual representations of the real world or objects within it [6]. The first applications focused on entertainment, although they explored other areas such as marketing and engineering [7–9]. Continuing with the evolution and in order to provide the user with a range of experiences that resemble real ones, immersive environments have been implemented [4]. This allows the user to have the perspective of living in one reality and experiencing another synthetically at the same time.

Approaches based on interaction with a user, body language, and gestures have allowed objects to be manipulated in VR. A full immersive system can incorporate a wide field of view, high resolution, a head-mounted display (HMD), and auditory and tactile or force feedback [10]. Unlike a real scenario, the applications that can be performed with a virtual environment are unlimited. Understanding a concept, learning a procedure or doing a recreational activity are possible thanks to VR. Its application is multidisciplinary and in areas such as education, it allows the development of practices in medicine, biology, military, geology, aeronautics, engineering, and so forth [6]. In Chen et al. [11], Parong et al. [12], and Park et al. [13], motivational, attitudinal and behavioral changes can be seen in the student–teacher interaction in the learning process. Virtually exploring scenes that in reality would not be possible, stimulates the student to better understand and memorize the academic content [9,14].

The benefits that have been obtained in the field of medicine, contribute to preventing and maintaining the state of health of the person [15]. In diseases like Parkinson’s [16–18], challenging activities are performed in a safe environment, as a tool for neurorehabilitation of the upper and lower extremities. As a complement, qualitative data can be obtained on the emotions and experiences that patients feel during experiments [19]. The utility of immersive virtual reality (IVR) systems in the rehabilitation of traumatic brain injuries can be seen in the review presented by Aida et al. [20]. People who have suffered a stroke are also subject to rehabilitation processes, replacing conventional practices with systems that simulate the development of games or interactive activities. [21–25]. In psychology, social signals can be analyzed in a virtual world that requires contrast with the real one [26]. It must be taken into account that the content developed must be personalized and optimized to stimulate the individual in the desired way [27].

Despite the advantages offered by IVR systems, the underlying methodologies and theories used to influence users must be understood, since the use of immersive technology in the long term could affect their behavior, perception, and motor skills [28,29]. These systems can be used to avoid bad habits, addictions or aggressive behavioral responses [30–32]. Cognitive stimulation is a fundamental strategy for the improvement and rehabilitation of mental capacities and executive functions, such as memory, attention, processing speed, and contextual learning [33,34], evaluating in this way the behavior of the participants and improving the conditions that unbalance their state of mental well-being [35]. Although the literature does not allow establishing the full effectiveness of IVR to counteract disorders such as dementia, potential distractors are reduced and the experience of people with mild cognitive impairment is improved [36].

IVR is considered a valid alternative tool for the rehabilitation of cognitive decline at all ages. De Luca et al. [37] described the case of a 15-year-old adolescent with traumatic brain injury (TBI) treated using CAREN (Computer Assisted Rehabilitation Environment), who obtained a significant improvement in his specific cognitive and motor domains. Similarly, in De Luca et al. [38], outstanding results in semi-immersive virtual rehabilitation in young adults (averaging 40 years old) who suffered from TBI are discussed. When performing cognitive therapies in older adults, positive emotional changes have been observed, with an opening to a broader application, as described by Appel et al. [26]. Although the immersive experience can produce side effects (dizziness, nausea, headache, and stomachache), it is more likely that non-immersive sessions are carried out in them, as presented by Gamito et al. [39] and Liu et al. [40]. The effect obtained can be influenced by age, therefore, Shakare et al. [41] develop a 3D environment for navigation and cycling, tested on participants of various ages (two groups of 26 and 64 years on average) to assess their experiences, as a precedent for future work.

Memory is evaluated using neuropsychological exams; VR offers tools to apply evaluations with greater cognitive demands of the participant. VR has been proven to provide fairer results with age, so assessments applied at different ages showed variations on the classical exams, but not on the memory VR exam [42]. VR has also been used to evaluate complex cognitive functions such as prospective memory, in the case of [43] authors confirmed the deterioration of this memory in the early stages of Alzheimer’s disease. In this way, VR has been inserted as a memory diagnosis and



rehabilitation tool, but there are few IVR studies aimed at evaluating memory, which motivates the development of applications with different levels of immersion [44].

The intelligence that characterizes the human being requires normal functioning of cognitive abilities. For this reason, memory requires being part of exercise and rehabilitation processes when the situation requires it. Dietrichkeit et al. [45] present a study carried out in healthy people and others with psychosis, determining that the positive effects that VR generates on the memory of the second group are greater. Mitrovic et al. [46] and Krokos et al. [47] present proposals for immersive systems to promote the development of prospective memory, in daily and long-term tasks, respectively. In Ventura et al. [48], the performance of episodic memory is compared when using immersive and non-immersive systems in healthy people. In this way, it is determined that the participants in the first group can recall a greater number of long-term events compared to the second.

Some memory-oriented IVR applications have been tested in healthy and patients that have some cognitive impairments to determine their effect on participants. Corriveau et al. [49] used a virtual store to memorize 12 familiar items and the results indicated that there were high levels of presence and higher levels of motivation for the VR tool in comparison with the traditional task. They also pointed out that memory performance in the VR task was positively correlated with performance on a traditional memory task in different age groups. Bréchet et al. [50] analyzed the first-person influence on IVR for virtualized episodes of everyday life and determined that delayed recovery performance can be improved when participants view their body as part of the virtual scene. Ouellet et al. [51] presented a virtual store to evaluate the daily memory in participants with and without cognitive impairment, whose results were validated with traditional questionnaires.

Cognitive functions deteriorate with aging and neurodegeneration, as has already been seen in the described literature. For this reason, motivating and effective proposals should be implemented to train these functions from middle age, preventing the advent of long-term mental problems. The type of system proposed (immersive or non-immersive), age, and other inherent physical and biological factors of the participants must be taken into account, in order to offer an appropriate tool for each of them. Several investigations were developed using immersive environments focused on the different types of memory, with a greater preponderance to the long-term ones. In this context, this manuscript presents an interactive system using IVR for assessing and training memory. An application that includes virtual environments was developed in the Unity 3D video game engine and the Oculus Go (HMD) headset was used as an immersive device. The main contribution of the current work is the presentation of a low-cost solution intended for memory training purposes that can also be used in community-based environments.

This work is organized as follows. Section 2 includes the materials and methods, with the design of the proposed task to assess memory, its main features as well as the conducted experiments to validate the application. Section 3 presents the main results. Section 4 is devoted to the discussion and Section 5 deals with the conclusions and future work.

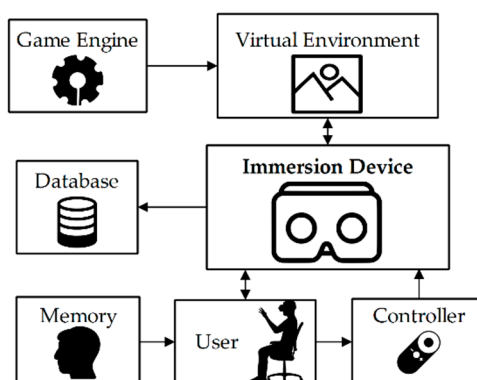
## 2. Materials and Methods

### 2.1. Formulation

A usable app designed to train memory using cognitive stimulation exercises is required. Traditional cognitive rehabilitation strategies consist of ordering patterns, memorizing events and performing mental operations, normally carried out in printed notebooks or using digital screens. There are also personalized cognitive stimulation sessions that require a specialist, which implies a greater investment of time, infrastructure, and money. These commonly applied tools can generate some type of stress to the user, reduce motivation and degrade treatment results.

The technology has an infinity of applications in rehabilitation. Specifically, VR combined with serious games has positive effects on the user, emulating therapeutic activities as entertainment. In addition, the use of immersion devices allows to improve concentration in cognitive rehabilitation,

excluding distractions present in the real environment. Figure 1 presents the proposal described in this document, where VR is used for the patient to interact with a set of predefined cognitive exercises through a hand controller. The system provides a virtual environment developed in a game engine, where all the visual and auditory information is played on the immersion device. The results of the games are also saved in a database for later review and analysis.



**Figure 1.** Formulation of the memory rehabilitation problem using an immersive virtual reality application.

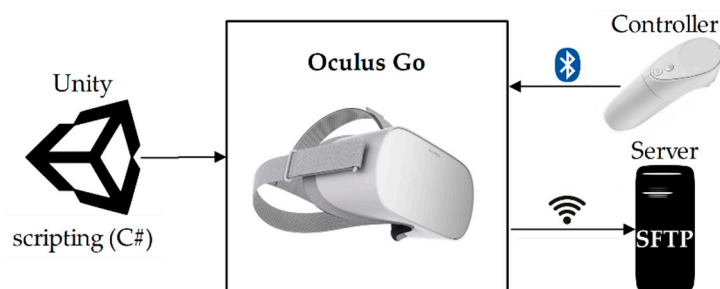
The proposed application differs from traditional techniques since the rehabilitation strategy consists of memorizing patterns while carrying out other interaction activities with the virtual environment. In this way, greater cognitive activity occurs, and the actions are fed back with sound to reinforce the immersion in the environment. The game is designed so that the user makes minimal movements, considering that the player's position must always be seated on a fixed chair to avoid collisions with objects in real space. In addition, the specialist can access the result history from anywhere, because the database sends the stored information to a file transfer server.

Within the serious game, the user has to walk through a maze in first person using the HMD device. While moving through the corridors geometric shapes appear, and the user has to remember both the color and the number of appearances. The analysis is carried out from two modes, autonomous and manual locomotion (user-controlled mode). In the autonomous mode, the player is automatically taken to the exit of the maze, whereas in the user-controlled mode, the player has to do it by commanding the Controller.

## 2.2. Components

Regarding the components required for this proposal, this focuses on implementing a wearable rehabilitation system that allows the user easily locate it anywhere in the home and it is economically accessible. Similarly, versatile and developer-friendly software (game engine) is required, which makes it easy to use immersion devices and enables the application to be linked to the file transfer server. In the current market, there is a great variety of HMDs with different input devices, as well as multiple game development environments. Consequently, the mentioned aspects are considered to select the necessary elements.

Figure 2 shows the components selected to implement this proposal, the HMDs to use are the Oculus Go that belong to the Oculus VR Company belonging to Facebook. This VR device is the successor of the Gear VR and its main feature is independence, since it does not require wiring, nor a Smartphone, nor a computer for its operation. Oculus Go is an all-in-one VR viewer for its display and built-in audio. In connectivity, it has Bluetooth 4.1 technology to communicate a single wireless controller, and it has Wifi 802.11ac communication to connect to the network.



**Figure 2.** Components of the immersive virtual reality application.

Technically, the HMD have the following characteristics: Android 7.1.2 operating system, system installed on a Qualcomm Snapdragon 821 chip, 3Gb LPDDR4 memory, 64 Gb storage (latest model), screen resolution of  $1280 \times 1440$  per eye, frequency 60 to 72 Hz refresh rate, 101 degree field of view, density of 12.67 pixels per degree of vision, Adreno 530 graphics processing unit, dimensions  $190 \text{ mm} \times 105 \text{ mm} \times 115 \text{ mm}$ , mass 468 g, integrated battery 2600 mAh for a range of two hours of play, and a price of approximately US \$ 200.

The remote input controller incorporated in the Oculus Go has an inertial measurement unit (IMU) to track 3 degrees of freedom of angular movement (useful as a pointer to interact with the virtual environment); it also includes a circular touch panel and four push buttons (Trigger, Back, Touchpad and Oculus). For its operation, a single AA battery powers it.

The Oculus Go have development compatibility with Unreal and Unity 3D, of these two game engines, the second has a more versatile and easy-to-develop work environment. Unity is a video game development platform with online support documentation, and has cross-platform compilation support. To build virtual environments Unity use the PhysX physics engine, animations using Mechanism technology and scripting is implemented in C# (.NET Framework). In relation to costs, Unity has two versions, a free personal and a professional one that requires payment.

For file transfer, an SFTP server from the University of Zaragoza is used, which allows the results to be sent in a secure manner. This is possible thanks to the connectivity of the device with the internet through a wireless network and the Microsoft Visual Studio libraries for file transfer protocols.

The advantages of this immersion device are remarkable, favoring the development of the application proposed in this work. The comfort of independence and the acceptable weight of the glasses are some of the benefits found. However, the excessive use of these HMD produces undesirable effects, some of the symptoms are dizziness, nausea, and vertigo, and worse still, when the user has health problems the risk increases, among the consequences are epileptic seizures, for this reason it is important to consult the player's background before considering him a participant in this proposal.

### 2.3. IVR Game Design

There are several possibilities to design a tool that exercises memory, but the most important thing is to provide it with simplicity to facilitate the use of the application and the analysis of the results. The game was initially designed to memorize geometric shapes within the virtual environment so that as the player progresses, more elements to memorize appear. The basic geometric shapes and the quantity of each one must be memorized; additionally the color assigned to each group of figures must be remembered, according to the level of difficulty selected. The user's journey is within a maze, from the entrance to the exit, solving the maze in first person. On the other hand, the maze navigation mode has two modes, the autonomous mode where the player only concentrates on memorizing the geometric shapes and their colors, and the manual mode (user-controlled mode) where the player controls the movements to find the exit. This last mode adds more elements to the cognitive exercise and allows analyzing the solution times of the maze.

Figure 3 presents the entire algorithm of the application from start to finish. Initially the user menu is displayed to record the player's data. This menu consists of an alphabetical keyboard to

enter the user’s names, considering that it can be selected from a pre-existing list of players, where the execution data is read and stored in the database and additionally an option is included to exit the game at any time. Then, a menu is presented to decide the navigation mode within the maze. In the autonomous mode, the navigation agent is enabled, whereas in manual mode, controlled locomotion is enabled and reproduces an aerial view to identify the way to the exit of the maze. This menu has the option to return to the previous menu.

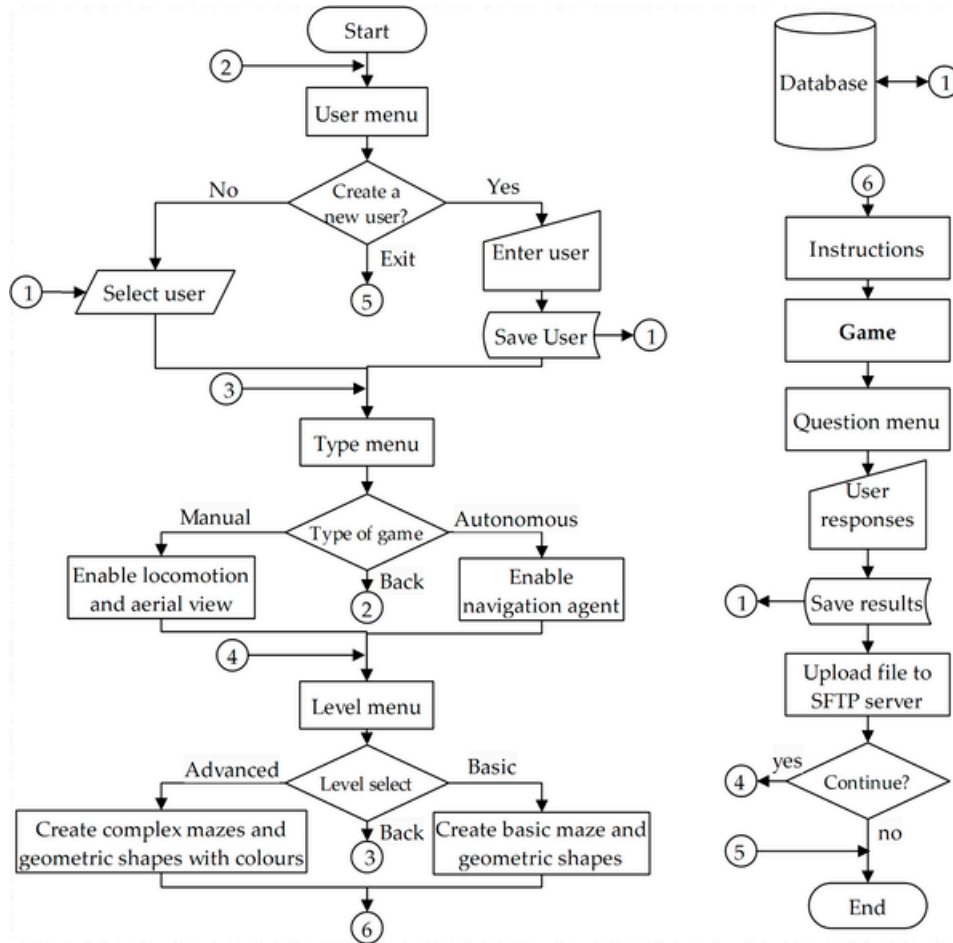


Figure 3. Algorithm of the cognitive rehabilitation application.

Below is the difficulty level menu, offering two options. The basic level (BL) generates a maze of low difficulty and locates the geometric shapes (square, triangle and circle) randomly (see Figure 4a). The advanced level (AL) generates a more complex maze and locates the geometric shapes with their respective colors (red, green and blue), one color for each type of shape (see Figure 4b). Regarding the generation of the maze, the internal configuration is produced in a random way so that the mazes are not repeated, in terms of the number of shapes, a maximum of ten are created for each shape, and the colors are also assigned randomly, this menu also has the option to return to the previous menu.

Returning to Figure 3. Once the level is selected, the instructions for the game are displayed for a certain time, the aerial view is played (in manual mode) and the game begins, considering that at any time the user can close from the game and return to the level menu. When the player reaches the exit of the maze, the menu of questions related to the number and color of the shapes is displayed. Entering the answers ends the game, saving the results in the database and sending the file to the SFTP server. Finally, the user decides whether to continue playing or exit the application.

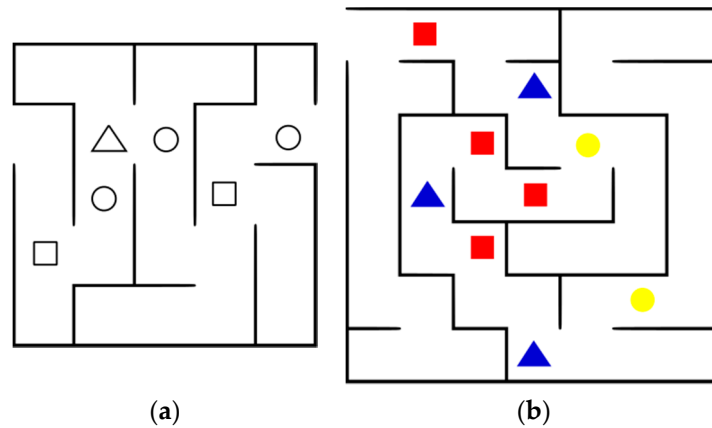


Figure 4. Difficulty levels: (a) Basic; (b) Advanced.

2.4. Development of the VR Application

The application is developed using the Unity 3D engine of game. Figure 5 presents the implemented scheme to develop the game; the main components are Game Objects and Scripts. The Unity environment allows creating the game scene, where all the Game Objects are inserted, starting from the camera that is linked to the VR device, the 3D models that make up the virtual environment and the two levels of difficulty of the maze, the sources of audio, and the different interaction menus, each component has a functionality that is controlled from the Scripts.

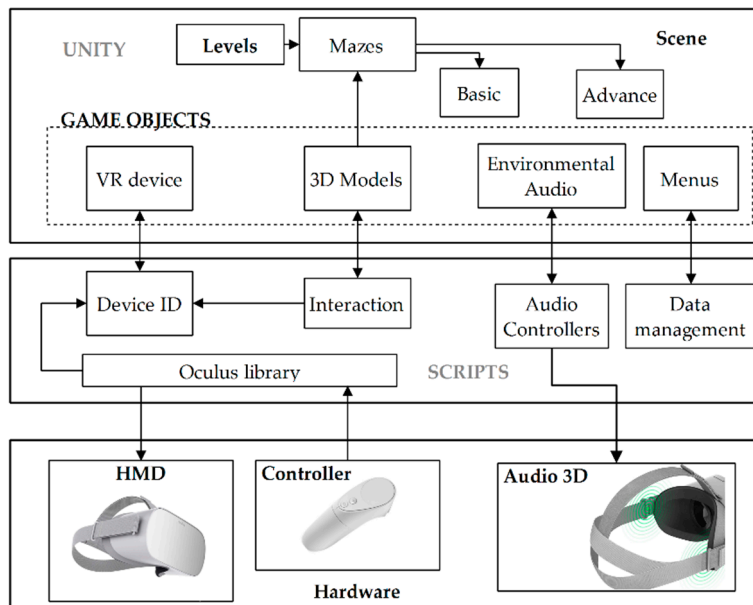


Figure 5. Diagram of the development of the immersive virtual reality application.

Scripts contain C# programming to link the different actions of the application. To implement these programs, several libraries are used that allow access to the hardware and functions required by the system. The interaction between external devices and Game Objects is done in different scripts, as well as events for audio playback. Data handling requires specific libraries that allow you to create, edit, and store the files, which also use the network connection to send the files to the remote server.

Next, the elements developed for the VR application are described, as shown in Figure 6. In the game mechanics, the links are made between all the menus from the start of the game to the user’s responses. The program activates and deactivates the Canvas as required, the menus are mainly made up of buttons, but it also uses dropdowns to show the options of existing users and the responses. In the

game, invisible colliders are created to detect when the user enters and exits the maze, which allows measuring time and activating the menu of questions. There are also colliders in the geometric shapes that are continuously rotating. They disappear on contact with the player and give a feedback to the user by means of a sound.

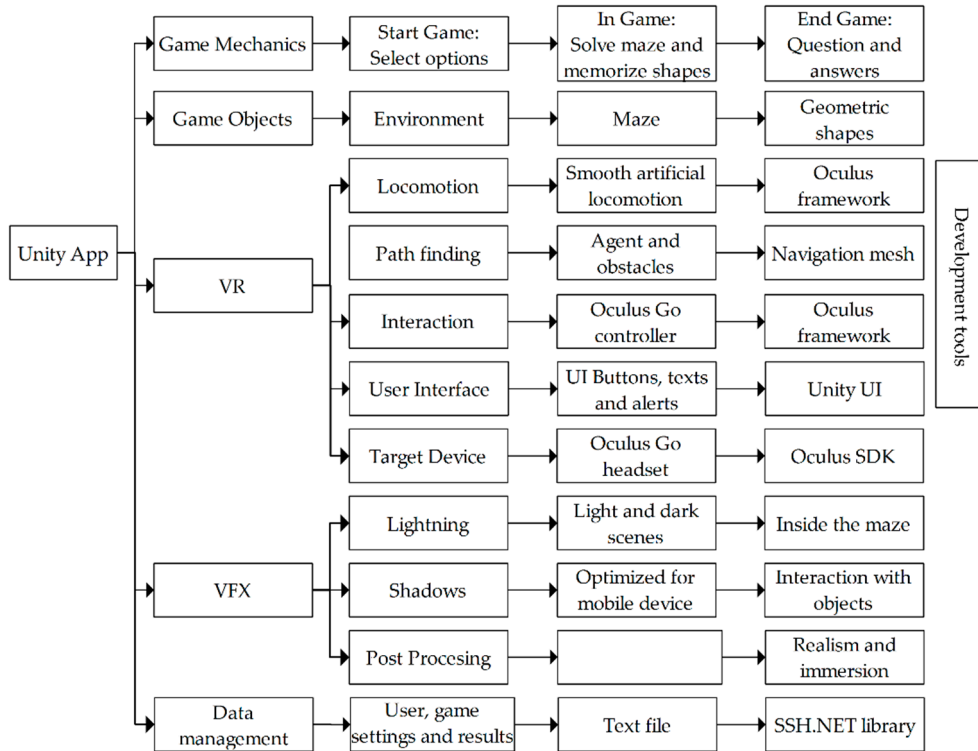


Figure 6. Developed elements of the virtual reality application.

The visual Game Objects are those that make up the scene environment, the maze and the geometric shapes. The environment consists of a field with grass, small country houses, water, trees, and stones, these elements were imported from different Assets. Mazes are generated automatically using a Pure Recursive cell-based algorithm, this 3D model is made up of three Prefabs (Walls, Pillars and Floors) that are located in the positions generated by the algorithm. The geometric shapes are positioned in the maze spaces at random and are Prefab with animation to rotate continuously.

Player movements are run using the Smooth Artificial Locomotion technique; the Oculus framework allows reading data from the Controller’s touchpad using the OVRInput.Get function (OVRInput.Axis2D.PrimaryTouchpad), to affect the position and orientation of the camera (kinematic) using the Transform property.

Autonomous navigation is possible thanks to the Path Finder of Unity 3D that allows you to navigate from one point to another automatically and avoiding obstacles. For this reason, it is necessary to add a NavMeshAgent to the player and an additional NavMeshObstacle to the possible collision objects, where a flat is created and set as Navegation Static to generate a Bake where the player can move. To activate this mode in the Script, the destination is configured and the Agent.isStopped is turned off. On the other hand, aerial view (manual mode) requires disabling the player’s navigation agent to raise the camera.

The user interaction with the menus is done through a virtual pointer linked to the movements of the Oculus Go Controller, this works through a Line Renderer that detects the collision with the elements of the Canvas, to confirm the selection, press the Trigger button (OVRInput.Button.Trigger)). The Back button allows you to stop a game and the Oculus button can be used to exit the application. Menus were created with Unity’s user interface (UI) tools and

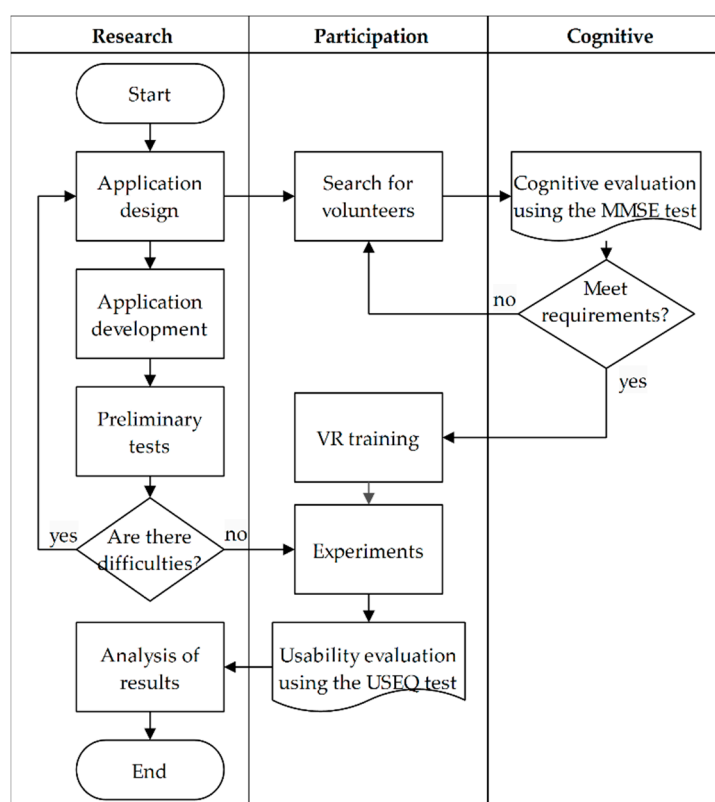
adding Colliders to buttons and dropdowns. To connect the virtual environment camera to the HMDs, the Prefab of the Oculus library called OVRCameraRig is used.

To conclude the edition of the virtual environment, the visual effects (VFX) are configured that produce a pleasant environment for the user. The lighting is adapted to distinguish some areas lighter than others, especially for the shadows generated within the maze. These shadows are generated using Lightmapping to optimize the consumption of resources on the mobile device, which improves interaction with objects. A post processing technique is also applied to improve the appearance on the camera and insert realism to the virtual environment; anti-aliasing softens the appearance of the graphics.

Finally, data management is implemented, where the information acquired is the username, the game configuration (type of game and level of difficulty), the correct answers, and the user's answers. The data is stored cumulatively in text files and sent to the SFTP server through the SSH: NET library, using functions of the SshNet.Sftp type.

### 2.5. Activities and Participants

This proposal is implemented following the processes in Figure 7, based on the design of the application detailed in Section 2.3, then the VR application is developed according to Section 2.4. The preliminary tests of the serious game are then carried out, analyzing the characteristics of the virtual environment and revealing possible errors; any detected difficulty requires improvements in the application.



**Figure 7.** Process diagram of the activities carried out.

Several changes were made according to this previous evaluation:

- The text was not very legible at certain distances due to the small size, so text font in menus and game instructions was enlarged.

- The menus were located below the level of the horizontal line of sight, requiring tilting the head to see all the option, so the menus were located in a higher position.
- The textures on the walls of the maze had a kind of discordance that affected aesthetics. Textures were configured to eliminate such errors.
- The aerial view changed very quickly and did not present a good angle of vision. For that reason, time was corrected and a better position for aerial view was established.
- The speed (both linear and angular) of locomotion (both autonomous and manual modes) were producing dizziness in the user; speed was reduced for the sake of comfortless.

Parallel to the development of the VR application, activities related to the participants are carried out, starting with the search for volunteers. The minimum requirements to consider a volunteer are to be at least 16 years old and agree to collaborate with the research, where the interested parties approved the informed consent to carry out the evaluations. Not all volunteers performed the experiments with the VR application, before a cognitive evaluation was performed using the Mini Mental State Examination (MMSE) test with adaptations to the participants [52]. The objective of this exam is to detect a possible deterioration in brain function that affects the use of the application, consequently, the results of the experiments, since this proposal is evaluated in healthy subjects of different ages.

Table 1 contains the MMSE test questions with their respective scores (total 30 points), this evaluation consists of 11 items. Temporal orientation -1- is analyzed by asking the volunteer for five data related to time, and spatial orientation -2- with five geographic location data. In the memory fixation -3- the patient is asked to repeat three words. In the attention or calculation -4- item, 3 is subtracted from the number 20 by 5 times, in case of presenting problems, it is asked to say the days of the week upside down. The memory -5- is evaluated by asking the words mentioned in the memory fixation. The denomination -6- is analyzed with the description of two objects. Then the user is asked to repeat -7- a phrase, and the language -8- is evaluated by reading and doing what a text indicates. Order tracking -9- is reviewed using three instructions given to the user, then the patient must write -10- a complete sentence (subject and predicate), and finally, the ability to copy -11- is evaluated by replicating two crossed pentagons using sticks.

**Table 1.** Mini mental state examination (MMSE) with adaptations.

Item	MMSE (Adaptation)	Score
1. Orientation in time	Year, date, Month, day, time of day	/5
2. Orientation in space	Place, floor, city, region, country	/5
3. Memory fixation	Apple, car, cow	/3
4. Attention—Calculation	Subtract 3 from 20 up to 5 times, or quote the 7 days of the week but upside down	/5
5. Reminder	Three objects learned instead	/3
6. Denomination	Pencil, shoe	/2
7. Repetition	“no, no, no, and no”	/1
8. Language	Read and do what is written: “close your eyes”	/1
9. Orders	Each individual is asked to follow the orders: ‘take this leaf, fold it in half, throw it on the ground’	/3
10. Writing	Each individual is asked to write a sentence	/1
11. Copy	Each individual is asked to draw the figure of two pentagons using 10 sticks	/1

The inclusion criteria to select the participants were: an MMSE score greater than 26, not having excess sensitivity to movement or motion sickness, and having no brain disorders or lesions that produce epilepsy. In total, 29 participants were recruited from the city of Ambato (Ecuador), whose characteristics are presented in Table 2. As far as formal education is concerned, participants had an average of 15.28 years (SD = 4.5), 62% had university studies and 38% did not. Overall, 52% were male and 48% female, 41% had no experience with VR and only 17% exhibited full experience, 55% carried out



cognitive exercise regularly (for their own interest or because they worked in cognitive activities), and only 14% had a family history of neurodegenerative diseases. The average age of the participants was 31.41 (SD = 10.6) years old (ranged 16 to 64), and the group's average score on the MMSE test was 29.07/30.

**Table 2.** Characteristics of the participants

Demographics	Data	Demographics	Data
Gender		Education	
Male	15	University	18
Female	14	Non-university	11
Age		MMSE	
Mean	31	Mean	29.07
SD	10	SD	0.87
Experience VR		Family history	
None	12	Yes	4
Some	12	No	25
Full	5	Cognitive exercise	
		Yes	16
		No	13

In order to contrast the results obtained in our maze task, a control test was carried out by participants. The control test was performed using a face–name pairs test. This test was similar to the common memory tests about face–name pairs we can find in the literature [53,54]. In this case, we used a short-time version that did not require several days for acquisition like in [53]. In the experiment, each participant had to memorize a sequence of 30 named faces (using 6 s per image), and then had to match faces with their respective names. We stored the response accuracy and completion times for every participant.

Prior to the experiments, all participants were trained in virtual reality using the Oculus Go, this to level the expertise in the use of IVR. Then, in the experiments, the participants generated results periodically and under similar conditions. After finishing the experiments, participants answer a simplified 6-question usability test to evaluate the VR application.

### 2.6. Statistical Analysis

We conducted Pearson's correlation tests to determine whether there were a positive and significant correlation between the participants' response accuracy in both the face–name pairs test and our maze task. We also evaluated the correlation to determine whether the years of formal education showed a significant positive correlation with performance on the task and to determine if the response accuracy or the completion times were sensitive to the changes related to age. T-student test were conducted when examining the effect of education on accuracy as well as to find for differences by gender in both response accuracy and completion times. The statistical significance was set at  $p < 0.05$ .

## 3. Results

### 3.1. Virtual Environment

After implementing the final corrections to the application, the final VR environment is obtained. Figure 8 presents some views of the basic level, showing the user menu with the keyboard to enter the names, the pre-game instructions, the maze from the aerial view, and the interior of the maze with the colorless geometric shapes. All the information in the system is presented in the Spanish language because the participants are Spanish speakers.

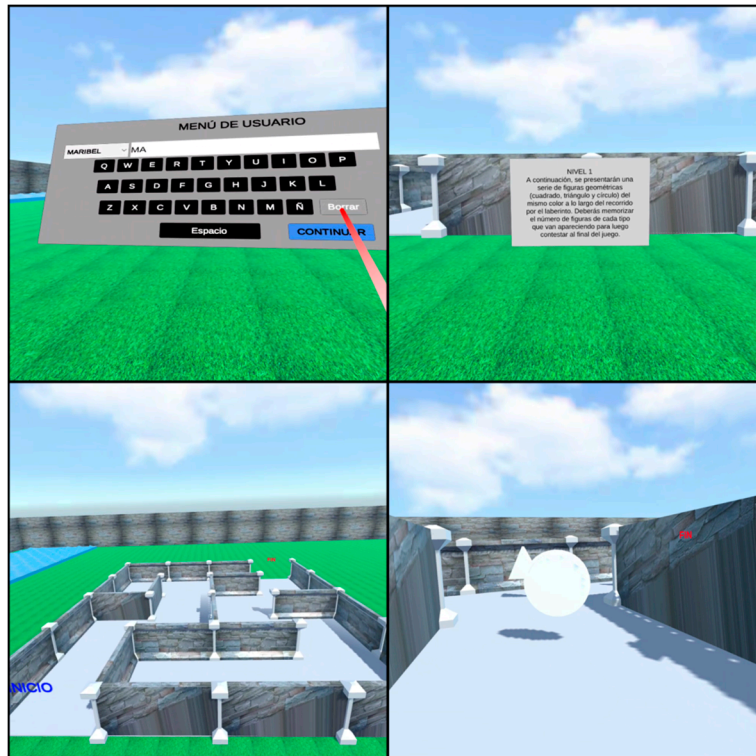


Figure 8. Immersive virtual reality scene views at the basic level.

Figure 9 shows more images of the virtual environment, this time the level menu, the maze of the second difficulty level, the interior view of the maze with colored geometric shapes, and the question and answer Canvas for the end of the game are presented. The landscapes are visibly attractive and the programmed functions work correctly. Due to the optimization of resources, the application requires a space of 45 Mb for its installation.

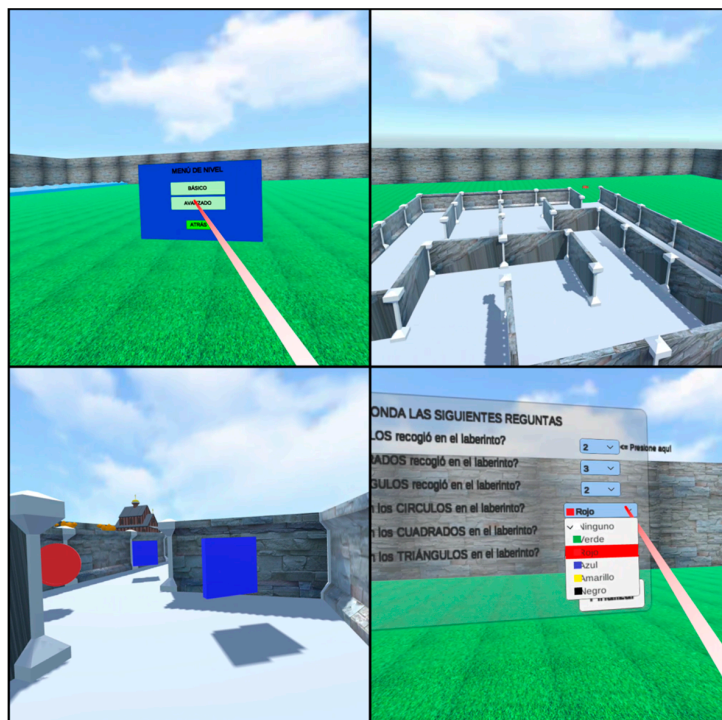


Figure 9. Immersive virtual reality scene views at the advanced level.

### 3.2. Experimentation

The tests were carried out with the participants by means of two Oculus Go VR Headset working simultaneously. Participants initially were trained for two weeks to become familiar with the equipment. Figure 10 shows some participants using the application, the experiments were carried out for 1 month and each participant performs at least ten tests in each of the game levels (basic and advanced).



Figure 10. Participants using the immersive virtual reality application.

#### 3.2.1. Autonomous Mode

Figure 11 depicts the results of the participants in the autonomous mode, where the players only memorize the geometric shapes without worrying about the movements within the maze. At the basic level, there is a maximum of three correct answers per test, and the participants performed ten tests. At the advanced level, there is a maximum of six correct answers per test and participants performed ten tests to accomplish the autonomous mode task. Across all the participants, mean response accuracy (correct answers percentage) was high (85% on average), being higher for the advanced level (86.6% on average) regarding the basic one (81.8% on average). All participants achieved accuracy at or above 50%. The total time to accomplish the task was 65 s for the first level and 97 s for the second one. Figure 11 shows the results of the experiment for both levels basic (a) and advanced (b).

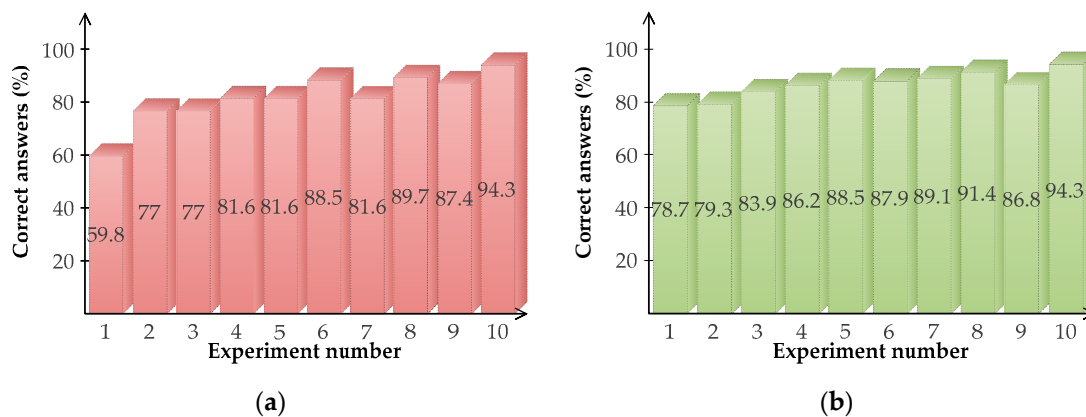
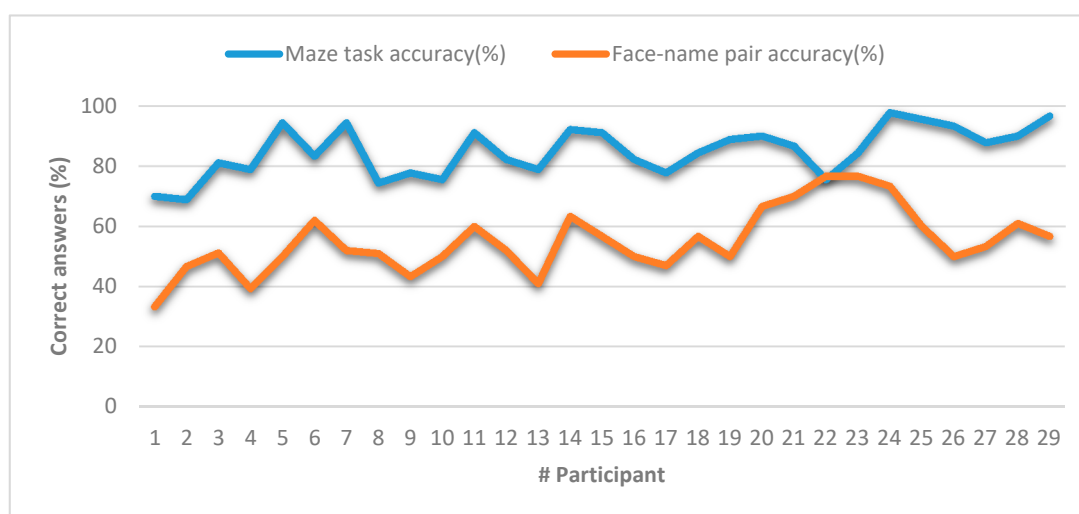


Figure 11. Results of the immersive virtual reality application in the autonomous game mode: (a) Success at the basic level; (b) Success at the advanced level.

Significant differences were found in the mean response accuracy by gender in the whole of the task ( $t(27), p = 0.046$ ) although not in each one of the levels of difficulty (BL:  $t(27), p = 0.065$ , AL:  $t(27), p = 0.278$ ). In this case, males performed better than females ( $M = 87.7, SD = 6.06\%$  versus  $M = 81.7, SD = 9.3$ ).

When examining the effect of education on accuracy, participants with a formal education greater than or equal to 14 years had a significantly better performance ( $M = 87.25\%, SD = 7.43\%$  versus  $M = 80.77\%, SD = 8.01\%$ ;  $t(27) = 2.17; p = 0.039$ ). In addition, the years of formal education show

a significant positive correlation with performance on the task ( $r = 0.465$ ,  $p = 0.011$ ). In order to determine if the response accuracy in this task was sensitive to changes related to age, we evaluated the correlations between age with the accuracy of the response and we did not find any association. We also conducted the face–name pair test [54], broadly used for memory assessment purposes. Figure 12 compares the mean response accuracy for both the maze task and the face–name pairs test, where one can observe that both measurements methods followed similar trends and shapes. In order to corroborate such assumption, we conducted Pearson’s correlation test between the results of both memory measurement methods. Table 3 shows the results of this correlation test. According to the results, we found a positive and significant correlation between the participants’ response accuracy in both the face–name pairs test and our maze task ( $r = 0.435$ ,  $p = 0.018$ ), which was medium–high according to Cohen criteria [55].



**Figure 12.** Comparison of memory measurements between the maze task and the face–name pair test in autonomous mode.

**Table 3.** Correlation between the response accuracy of both the maze task and the face–name pair test (autonomous mode).

		Maze Task	Face–Name Pair Test
Maze Task	Pearson Correlation	1	0.435 *
	Sig. (2-tailed)		0.018
	N	29	29
Face–Name Pair Test	Pearson Correlation	0.435 *	1
	Sig. (2-tailed)	0.018	
	N	29	29

\* Correlation is significant at the 0.05 level (2-tailed).

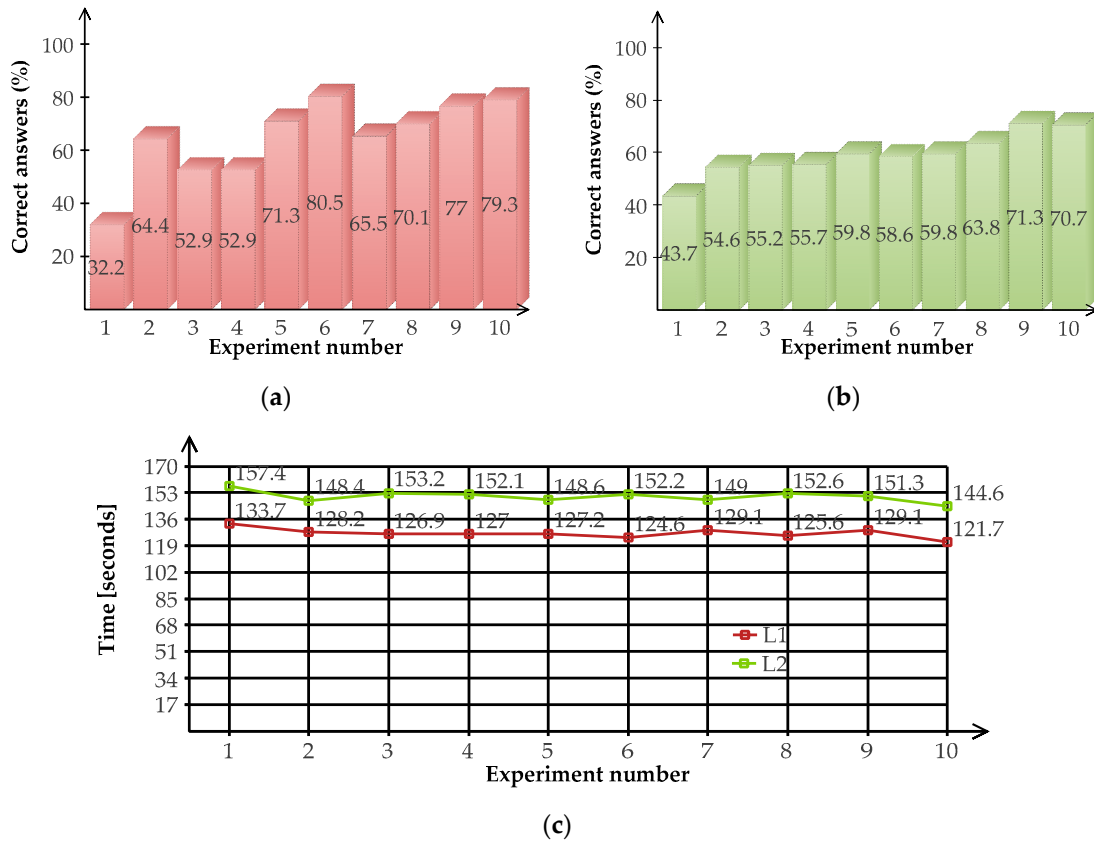
### 3.2.2. User-Controlled Mode

Within this mode, players memorize geometric shapes and control the movements within the maze. The number of performed tests by participants was the same as in the autonomous mode (ten tests in each level).

There were no significant differences in the average response accuracy by sex neither in the task as a whole ( $t(27)$ ,  $p = 0.195$ ) nor within levels of difficulty (BL:  $t(27)$ ,  $p = 0.193$ , AL:  $t(27)$ ,  $p = 0.405$ ). The same applies in terms of global ( $t(27)$ ,  $p = 0.934$ ) and partial (BL:  $t(27)$ ,  $p = 0.704$ , AL:  $t(27)$ ,  $p = 0.869$ ) completion times.

Across all the participants, the average response accuracy (percentage of correct answers) was moderate (61% on average), being higher at the basic level (64.6 %) in comparison with the advanced

level (59.3%). All participants except one (46.67%) exhibited an accuracy greater than 50%. The total completion time of participants as a whole ranged between 105.15 and 155.04 s. The average total completion time was 139.35 (SD = 10.43) seconds. The average completion times for the basic level and advanced level were 127 and 152 s, respectively. Figure 13 shows the participants' results in the user-controlled mode (both response accuracy and completion times, respectively).

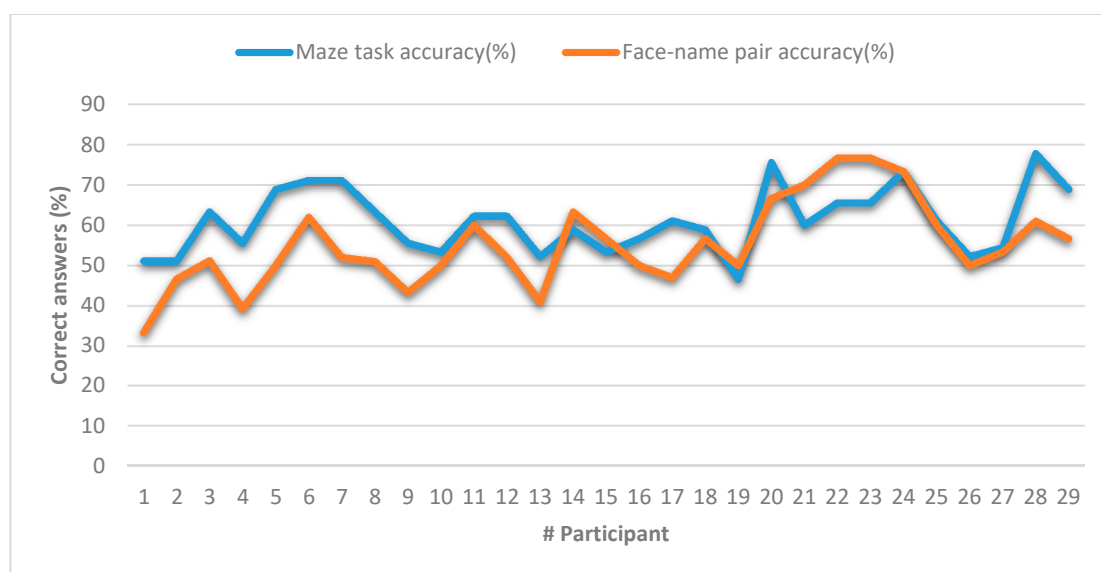


**Figure 13.** Results of the immersive virtual reality application in the user-controlled mode of the game: (a) Success rate at the basic level; (b) Success rate at the advanced level; (c) Maze completion times.

By examining the effect of education on response accuracy and completion time, participants with a formal education of 14 years or higher performed significantly better ( $M = 63.68\%$ ,  $SD = 8.4\%$  versus  $M = 56.11\%$ ,  $SD = 4.54\%$ ;  $t(27) = 2.63$ ;  $p = 0.014$ ). Furthermore, the years of formal education show a significant positive correlation with the performance on the task ( $r = 0.463$ ,  $p = 0.01$ ). We did not find any association with the total completion times of the task.

In the same way, as we did in the autonomous mode, we compared the mean response accuracy for both the maze task and the face–name pairs test (see Figure 14). In order to confirm if a linear correlation may exist, we conducted Pearson’s correlation test between the results of both memory measurement methods. Table 4 shows the results of this correlation test. According to the results, we found a positive and significant correlation between the participants’ response accuracy in both the face–name pairs test and our maze task under a user-controlled mode ( $r = 0.577$ ,  $p = 0.001$ ), which is high according to Cohen criteria [55].

Finally, to determine if the response accuracy or the completion times in this task were sensitive to the changes related to age, we evaluated the correlations between age with the response accuracy and with the completion time for the different levels of the task (BL and AL). Age was not significantly associated neither with response accuracy nor with the completion time in the two levels of the task ( $p > 0.05$  in both cases). The same happened (no significant association for completion times and response accuracy in the face–name pair test).



**Figure 14.** Comparison of memory measurements between the maze task and the face-name pair test in user-controlled mode.

**Table 4.** Correlation between the response accuracy of both the maze task and the face-name pair test (user-controlled mode).

		Maze Task	Face-Name Pair Test
Maze Task	Pearson Correlation	1	0.577 **
	Sig. (2-tailed)		0.001
	N	29	29
Face-name pair Test	Pearson Correlation	0.577 **	1
	Sig. (2-tailed)	0.001	
	N	29	29

\*\* Correlation is significant at the 0.01 level (2-tailed).

### 3.3. User Evaluation

To evaluate the application from the perspective of the participants, the USEQ satisfaction test (User Satisfaction Evaluation Questionnaire) [56] was applied. It allows us to measure the usability of VR applications for rehabilitation and consists of six questions evaluated from 1 to 5. Table 5 presents the test results, obtaining an average score of 28.36 (SD = 0.46), showing a high degree of satisfaction of the participants.

**Table 5.** USEQ test results for the maze task.

Question	Mean	SD
Q1. Did you enjoy your experience with the system?	4.91	0.26
Q2. Were you successful using the system?	4.79	0.41
Q3. Were you able to control the system?	4.52	0.62
Q4. Is the information provided by the system clear?	4.97	0.18
Q5. Did you feel discomfort during your experience with the system?	4.45	0.85
Q6. Do you think that this system will be helpful for rehabilitation?	4.72	0.45
	28.36	0.46

In general, users express their satisfaction with this experience, mentioning that all the elements of the application are comfortable to use and the information presented is quite clear. At the beginning of the experiment, there were some participants dissatisfied with the application because they experienced

dizziness at first, but then they adapted to the environment. In general, the participants think that the system can be helpful for rehabilitation purposes.

#### 4. Discussion

VR has been explored as a cognitive rehabilitation tool [37–40]. Specifically, IVR has not reached its maximum expression in rehabilitation due to the side effects it produces [39,40], although there are results that show a better response in immersive systems for cognitive rehabilitation [46–48,50,51]. We believed that IVR systems based on a head-mounted display (HMD) offer many advantages in comparison with traditional treatments. Namely, customization based on user's needs, possibility to graduate, low cost, more in terms of presence and ecological validity [57].

The main goal was to develop a task to assess the memory by exploiting the benefits of an IVR environment. At the same time, the task was intended for memory training purposes, especially focused on attentional memory. The application was developed using basic elements of the Unity 3D game engine, which has optimized the features and reduced the memory space required. Furthermore, the system constantly collects the generated information and sends it to an external server that allows the results to be easily extracted. The results based on by 29 patients of different ages (ranged 16 to 64) showed that the accuracy of participants measured in percentage of correct answers in a controlled environment was correlated (statistically significantly) with the response accuracy of participants in retrieving face–name associations in a validated type of memory test.

The observed correlations between the response accuracy in both the maze task and the face–pair test [54] align with other studies. In particular, González-Landero et al. [53] designed a smart cupboard (SC) as a tool to perform memory measurements and they also found a significant correlation between the accuracy response in both the SC and face–pair test for a sample of 23 adults. Like in their study, we observed that the participants' results of the face–pair test were well below the results achieved by the participants in the maze task. One plausible explanation deals with the fact that attention appears to be able to influence items already stored in visual memory. Our application works sustained attention, since it works the ability to focus and maintain attention on a task over a long period [58,59]. This idea is in line with the study of Murray and colleagues [60], who showed that selective attention could restore forgotten items to visual short-term memory (VSTM). Therefore, if we direct attention to items already encoded in memory, the probability of their recall improves. Furthermore, they stated that attention could rescue information that would otherwise be lost or unavailable to retrieval processes. Other authors such as Zang and Luck, demonstrated that attention protects items from being forgotten [61], whereas Matsukura and colleagues' work suggested that attention can assist in selectively encoding items into visual memory [62]. This suggests to us that perhaps we should bring these values closer together, probably by increasing the difficulty of the task. In fact, in the user-controlled mode (more difficult for the user) the correlations between our task and the face pair test were greater. It opens the door to new designs in which the difficulty of the task is slightly increased.

On the other hand, the results of completion times in the maze task indicated that there were important differences between the two modes (autonomous and controlled). The user-controlled mode involves introducing a distracting variable as an interference that made the completion more difficult for the participants (at both levels). In line with the abovementioned fact, the inclusion of some distracting elements can increase the difficulty and consequently, make the task more similar to realistic daily conditions.

Finally, in spite of the fact that some studies have reported side effects such as nausea or dizziness that are indicative of “simulator sickness” related to vestibular–optical reflexes [63,64], the participants did not present considerable discomfort with the application because the player's speeds were adjusted to a minimum to avoid dizziness and other side effects of the headset. This was achieved despite the wide age range of the users who evaluated this proposal, although some users wanted to increase this

speed, at the risk of having these effects, which is not convenient if we want to use the application on patients in the future.

However, this study had several limitations. First, we did not compare non-treated controls, so it is difficult to evaluate the degree of effectiveness of our cognitive task. Instead of comparing it with a non-treated control, we compared the experimental group performance with a well-known test [54] by means of Pearson's correlation.

We also find that neither the response accuracy nor the completion times in this task were sensitive to the changes related to age. As far as completion times and response accuracy in the face–name pair test, we also find any association, partly due to the low average age in the sample. This fact is very important because there is a deterioration of memory with age and in some neurodegenerative diseases. Therefore, we should consider a greater sample for future studies, and if possible, with more presence of older subjects, in order to elucidate whether the task can be sensitive either in response accuracy or in completion times to age. This will allow us to extract interesting conclusions for application to a population with neurodegenerative diseases. To support this theory, longer studies should be conducted over time in a population of subjects suffering some neurodegenerative diseases such as Alzheimer's or Parkinson's diseases, and at different stages of the disease evolution. Such studies could confirm our hypotheses: first, to evaluate if the developed task could serve as a training task to improve short-term memory and second, to evaluate if the task could help to detect memory losses and eventually detect the disease at earlier stages. The inclusion of people more likely to develop a neurodegenerative disease due to genetic factors, for example, could be of capital importance to perform a better evaluation of our tool.

## 5. Conclusions and Future Work

In this preliminary study, we developed a virtual reality-based immersive application intended for both memory assessment and memory training purposes. A low-cost device (the Oculus Go HMD headset) was used as an immersive device. The results on response accuracy based on 29 participants showed that the accuracy of our task was correlated (statistically significantly) with the response accuracy of participants in retrieving face–name associations in the validated face–pair test assessment. Therefore, we ascertained that our task to assess memory converges with other extant and popular memory assessments such as the face–pair test assessment.

Future work deals with the creation of a robust tool for cognitive rehabilitation purposes by exploiting the benefits of immersive and low-cost technologies. They open the door to studies to elucidate which is better and under what conditions; taking into account the type of subjects/patients, age, etc. Thus, we intend to establish experiments with control groups that use a non-immersive technology compared to experimental groups using purely immersive technology through HMD such as the Oculus Go headset. We want to evaluate the tool in community-based environments before stepping into clinical settings. It is our goal to provide the tool with virtual environments closer to reality, and specifically close to activities of daily living (ADL), since the obtained results in the experimental setups are better transferred into daily life.

The obtained results also showed improvements in the memory retention of users as they use the application, especially when they are only concerned with memorizing geometric shapes (autonomous mode). This can lead us to use the tool for training purposes too [65]. The developed application also works attention, which is very important in diseases such as Alzheimer's, where one of the possible neuropsychological markers deals with the attentional deterioration those patients may suffer in the preclinical phase of the disease. Thanks to mental dexterity tasks such as the one developed in this study, we can stimulate these cognitive functions. The application can also warn us of a deficit in sustained attention that may occur in other neuropsychiatric disorders. With this idea in mind, we plan to evaluate other cognitive functions such attention, immediate recognition memory, etc., in the same way as in the study of Kang [66].



Another line of this work is related to the introduction of cueing in cognitive tasks. Murray and colleagues showed that a specific type of cueing may improve recall for items that otherwise would have been irretrievable, providing critical evidence that attention can restore forgotten information to VSTM [60]. We think that immersive technology may improve that process.

We have left in the air one of the modes of operation, the user-controlled mode, in which the user must manage his journey through the maze to find the exit and finish the test. We intend to work on it in the future as well, to investigate how or to what extent interference that occupies our working memory capacity affects final performance. We hypothesize that adequate and sustained training over time can improve our working memory, and, consequently our short-term memory [67].

**Author Contributions:** Conceptualization, J.V.-A., R.A. and G.P.-N.; Investigation, J.V.-A., R.A., G.P.-N. and I.G.-M.; Methodology, J.V.-A., R.A. and G.P.-N.; Resources, J.V.-A.; Software, J.V.-A.; Supervision, G.P.-N., R.A. and I.G.-M.; Validation, J.V.-A. and G.P.-N.; Visualization, J.V.-A.; Writing—original draft, J.V.-A. and G.P.-N.; Writing—review and editing, J.V.-A., G.P.-N. and I.G.-M. All authors have read and agreed to the published version of the manuscript.

**Funding:** This research and the APC was funded by Universidad Tecnológica Indoamérica (Ecuador).

**Acknowledgments:** The authors wish to thank the participants and the Universidad Tecnológica Indoamérica for the support provided in this research.

**Conflicts of Interest:** The authors declare no conflict of interest.

## References

- Farshid, M.; Paschen, J.; Eriksson, T.; Kietzmann, J. Go boldly!: Explore augmented reality (AR), virtual reality (VR), and mixed reality (MR) for business. *Bus. Horiz.* **2018**, *61*, 657–663. [\[CrossRef\]](#)
- Wolfartsberger, J. Analyzing the potential of Virtual Reality for engineering design review. *Autom. Constr.* **2019**, *104*, 27–37. [\[CrossRef\]](#)
- Yung, R.; Khoo-Lattimore, C. New realities: A systematic literature review on virtual reality and augmented reality in tourism research. *Curr. Issues Tour.* **2019**, *22*, 2056–2081. [\[CrossRef\]](#)
- Alcañiz, M.; Bigné, E.; Guixeres, J. Virtual Reality in Marketing: A Framework, Review, and Research Agenda. *Front. Psychol.* **2019**, *10*, 1530. [\[CrossRef\]](#)
- Kim, Y.; Kim, H.; Kim, Y.O. Virtual Reality and Augmented Reality in Plastic Surgery: A Review. *Arch. Plast. Surg.* **2017**, *44*, 179–187. [\[CrossRef\]](#)
- Dunn, J.; Yeo, E.; Moghaddampour, P.; Chau, B.; Humbert, S. Virtual and augmented reality in the treatment of phantom limb pain: A literature review. *NeuroRehabilitation* **2017**, *40*, 595–601. [\[CrossRef\]](#)
- Nilsson, N.C.; Serafin, S.; Steinicke, F.; Nordahl, R. Natural walking in virtual reality: A review. *Comput. Entertain.* **2018**, *16*, 1–22. [\[CrossRef\]](#)
- Loureiro, S.M.C.; Guerreiro, J.; Eloy, S.; Langaro, D.; Panchapakesan, P. Understanding the use of Virtual Reality in Marketing: A text mining-based review. *J. Bus. Res.* **2019**, *100*, 514–530. [\[CrossRef\]](#)
- Román-Ibáñez, V.; Pujol, F.A.; Mora, H.; Pertegal-Felices, M.L.; Jimeno-Morenilla, A. A Low-Cost Immersive Virtual Reality System for Teaching Robotic Manipulators Programming. *Sustainability* **2018**, *10*, 1102. [\[CrossRef\]](#)
- Eslater, M. Immersion and the illusion of presence in virtual reality. *Br. J. Psychol.* **2018**, *109*, 431–433. [\[CrossRef\]](#) [\[PubMed\]](#)
- Cheng, K.; Tsai, C.-C. A case study of immersive virtual field trips in an elementary classroom: Students' learning experience and teacher-student interaction behaviors. *Comput. Educ.* **2019**, *140*, 103600. [\[CrossRef\]](#)
- Parong, J.; Mayer, R.E. Learning science in immersive virtual reality. *J. Educ. Psychol.* **2018**, *110*, 785–797. [\[CrossRef\]](#)
- Park, S.H.; Ryu, J. Exploring Preservice Teachers' Emotional Experiences in an Immersive Virtual Teaching Simulation through Facial Expression Recognition. *Int. J. Hum. Comput. Interact.* **2018**, *35*, 521–533. [\[CrossRef\]](#)
- Stepan, K.; Zeiger, J.; Hanchuk, S.; Del Signore, A.; Shrivastava, R.; Govindaraj, S.; Iloreta, A. Immersive virtual reality as a teaching tool for neuroanatomy. *Int. Forum Allergy Rhinol.* **2017**, *7*, 1006–1013. [\[CrossRef\]](#) [\[PubMed\]](#)

15. Wiederhold, B.K.; Riva, G. Virtual Reality Therapy: Emerging Topics and Future Challenges. *Cyberpsychol. Behav. Soc. Netw.* **2019**, *22*, 3–6. [[CrossRef](#)] [[PubMed](#)]
16. Kim, A.; Darakjian, N.; Finley, J.M. Walking in fully immersive virtual environments: An evaluation of potential adverse effects in older adults and individuals with Parkinson's disease. *J. Neuroeng. Rehabil.* **2017**, *14*, 1–12. [[CrossRef](#)] [[PubMed](#)]
17. Cikajlo, I.; Potisk, K.P. Advantages of using 3D virtual reality based training in persons with Parkinson's disease: A parallel study. *J. Neuroeng. Rehabil.* **2019**, *16*, 119. [[CrossRef](#)]
18. Sánchez-Herrera-Baeza, P.; Cano-De-La-Cuerda, R.; Oña-Simbaña, E.D.; Palacios-Ceña, D.; Pérez-Corrales, J.; Cuenca-Zaldivar, J.N.; Güeita-Rodríguez, J.; Carlos, B.; Alberto, J.; Cuesta-Gomez, A. The Impact of a Novel Immersive Virtual Reality Technology Associated with Serious Games in Parkinson's Disease Patients on Upper Limb Rehabilitation: A Mixed Methods Intervention Study. *Sensors* **2020**, *20*, 2168. [[CrossRef](#)]
19. Sokolov, A.A.; Collignon, A.; Bieler-Aeschlimann, M. Serious video games and virtual reality for prevention and neurorehabilitation of cognitive decline because of aging and neurodegeneration. *Curr. Opin. Neurol.* **2020**, *33*, 239–248. [[CrossRef](#)]
20. Aida, J.; Chau, B.; Dunn, J. Immersive virtual reality in traumatic brain injury rehabilitation: A literature review. *NeuroRehabilitation* **2018**, *42*, 441–448. [[CrossRef](#)]
21. Almousa, M.; Al-Khalifa, H.S.; Al-Sobayel, H. Requirements Elicitation and Prototyping of a Fully Immersive Virtual Reality Gaming System for Upper Limb Stroke Rehabilitation in Saudi Arabia. *Mob. Inf. Syst.* **2017**, *2017*, 1–12. [[CrossRef](#)]
22. Ronchi, R.; Perez-Marcos, D.; Giroux, A.; Thomasson, M.; Serino, A.; Saj, A.; Blanke, O. Use of immersive virtual reality to detect unilateral spatial neglect in chronic stroke. *Ann. Phys. Rehabil. Med.* **2018**, *61*, e90–e91. [[CrossRef](#)]
23. Weber, L.M.; Nilsen, D.M.; Gillen, G.; Yoon, J.; Stein, J. Immersive Virtual Reality Mirror Therapy for Upper Limb Recovery after Stroke: A Pilot Study. *Am. J. Phys. Med. Rehabil.* **2019**, *98*, 783–788. [[CrossRef](#)] [[PubMed](#)]
24. Huang, Q.; Wu, W.; Chen, X.; Wu, B.; Wu, L.; Huang, X.; Jiang, S.; Huang, L. Evaluating the effect and mechanism of upper limb motor function recovery induced by immersive virtual-reality-based rehabilitation for subacute stroke subjects: Study protocol for a randomized controlled trial. *Trials* **2019**, *20*, 1–9. [[CrossRef](#)]
25. De Luca, R.; Buono, V.L.; Leo, A.; Russo, M.; Aragona, B.; Leonardi, S.; Buda, A.; Naro, A.; Calabrò, R.S. Use of virtual reality in improving poststroke neglect: Promising neuropsychological and neurophysiological findings from a case study. *Appl. Neuropsychol. Adult* **2017**, *26*, 96–100. [[CrossRef](#)]
26. Appel, L.; Appel, E.; Bogler, O.; Wiseman, M.; Cohen, L.; Ein, N.; Abrams, H.B.; Campos, J.L. Older Adults With Cognitive and/or Physical Impairments Can Benefit From Immersive Virtual Reality Experiences: A Feasibility Study. *Front. Med.* **2020**, *6*, 329. [[CrossRef](#)]
27. Crescentini, C.; Chittaro, L.; Capurso, V.; Sioni, R.; Fabbro, F. Psychological and physiological responses to stressful situations in immersive virtual reality: Differences between users who practice mindfulness meditation and controls. *Comput. Hum. Behav.* **2016**, *59*, 304–316. [[CrossRef](#)]
28. Lanier, M.; Waddell, T.F.; Elson, M.; Tamul, D.J.; Ivory, J.D.; Przybylski, A.K. Virtual reality check: Statistical power, reported results, and the validity of research on the psychology of virtual reality and immersive environments. *Comput. Hum. Behav.* **2019**, *100*, 70–78. [[CrossRef](#)]
29. Chessa, M.; Maiello, G.; Borsari, A.; Bex, P.J. The Perceptual Quality of the Oculus Rift for Immersive Virtual Reality. *Hum. Comput. Interact.* **2019**, *34*, 51–82. [[CrossRef](#)]
30. Sobhani, A.; Farooq, B. Impact of smartphone distraction on pedestrians' crossing behaviour: An application of head-mounted immersive virtual reality. *Transp. Res. Part F Traffic Psychol. Behav.* **2018**, *58*, 228–241. [[CrossRef](#)]
31. Hudak, J.; Blume, F.; Dresler, T.; Haeussinger, F.B.; Renner, T.J.; Fallgatter, A.J.; Gawrilow, C.; Ehrlis, A.-C. Near-Infrared Spectroscopy-Based Frontal Lobe Neurofeedback Integrated in Virtual Reality Modulates Brain and Behavior in Highly Impulsive Adults. *Front. Hum. Neurosci.* **2017**, *11*, 425. [[CrossRef](#)] [[PubMed](#)]
32. Detez, L.; Greenwood, L.-M.; Segrave, R.; Wilson, E.; Chandler, T.; Ries, T.; Stevenson, M.; Lee, R.S.C.; Yücel, M. A Psychophysiological and Behavioural Study of Slot Machine Near-Misses Using Immersive Virtual Reality. *J. Gambl. Stud.* **2019**, *35*, 929–944. [[CrossRef](#)] [[PubMed](#)]
33. Kyrlitsias, C.; Michael-Grigoriou, D. Asch conformity experiment using immersive virtual reality. *Comput. Animat. Virtual Worlds* **2018**, *29*, e1804. [[CrossRef](#)]

34. Kroes, M.C.W.; Dunsmoor, J.E.; Mackey, W.E.; McClay, M.; Phelps, E.A. Context conditioning in humans using commercially available immersive Virtual Reality. *Sci. Rep.* **2017**, *7*, 8640. [[CrossRef](#)]
35. Gerber, S.M.; Jeitziner, M.-M.; Knobel, S.E.J.; Mosimann, U.P.; Müri, R.M.; Jakob, S.M.; Nef, T. Perception and Performance on a Virtual Reality Cognitive Stimulation for Use in the Intensive Care Unit: A Non-randomized Trial in Critically Ill Patients. *Front. Med.* **2019**, *6*, 287. [[CrossRef](#)] [[PubMed](#)]
36. Sayma, M.; Tuijt, R.; Cooper, C.; Walters, K. Are We There Yet? Immersive Virtual Reality to Improve Cognitive Function in Dementia and Mild Cognitive Impairment. *Gerontologist* **2019**, *60*, e502–e512. [[CrossRef](#)]
37. De Luca, R.; Portaro, S.; Le Cause, M.; De Domenico, C.; Maggio, M.G.; Ferrera, M.C.; Giuffrè, G.; Bramanti, A.; Calabrò, R.S. Cognitive rehabilitation using immersive virtual reality at young age: A case report on traumatic brain injury. *Appl. Neuropsychol. Child* **2019**, *9*, 282–287. [[CrossRef](#)]
38. De Luca, R.; Maggio, M.G.; Maresca, G.; Latella, D.; Cannavò, A.; Sciarrone, F.; Voi, E.L.; Accorinti, M.; Bramanti, P.; Calabrò, R.S. Improving Cognitive Function after Traumatic Brain Injury: A Clinical Trial on the Potential Use of the Semi-Immersive Virtual Reality. *Behav. Neurol.* **2019**, *2019*, 1–7. [[CrossRef](#)]
39. Gamito, P.; Oliveira, J.; Morais, D.; Coelho, C.; Santos, N.; Alves, C.; Galamba, A.; Soeiro, M.; Yerra, M.; French, H.; et al. Cognitive Stimulation of Elderly Individuals with Instrumental Virtual Reality-Based Activities of Daily Life: Pre-Post Treatment Study. *Cyberpsychol. Behav. Soc. Netw.* **2019**, *22*, 69–75. [[CrossRef](#)]
40. Liu, Y.; Tan, W.; Chen, C.; Liu, C.; Yang, J.; Zhang, Y. A Review of the Application of Virtual Reality Technology in the Diagnosis and Treatment of Cognitive Impairment. *Front. Aging Neurosci.* **2019**, *11*, 280. [[CrossRef](#)]
41. Sakhare, A.R.; Yang, V.; Stradford, J.; Tsang, I.; Ravichandran, R.; Pa, J. Cycling and Spatial Navigation in an Enriched, Immersive 3D Virtual Park Environment: A Feasibility Study in Younger and Older Adults. *Front. Aging Neurosci.* **2019**, *11*, 218. [[CrossRef](#)] [[PubMed](#)]
42. Pflueger, M.O.; Stieglitz, R.-D.; Lemoine, P.; Leyhe, T. Ecologically relevant episodic memory assessment indicates an attenuated age-related memory loss—A virtual reality study. *Neuropsychology* **2018**, *32*, 680–689. [[CrossRef](#)] [[PubMed](#)]
43. Lecouvey, G.; Morand, A.; Gonneaud, J.; Piolino, P.; Orriols, E.; Pélerin, A.; Da Silva, L.F.; De La Sayette, V.; Eustache, F.; Desgranges, B. An Impairment of Prospective Memory in Mild Alzheimer’s Disease: A Ride in a Virtual Town. *Front. Psychol.* **2019**, *10*, 241. [[CrossRef](#)] [[PubMed](#)]
44. La Corte, V.; Sperduti, M.; Abichou, K.; Piolino, P. Episodic Memory Assessment and Remediation in Normal and Pathological Aging Using Virtual Reality: A Mini Review. *Front. Psychol.* **2019**, *10*, 173. [[CrossRef](#)]
45. Dietrichkeit, M.; Grzella, K.; Nagel, M.; Moritz, S. Using virtual reality to explore differences in memory biases and cognitive insight in people with psychosis and healthy controls. *Psychiatry Res.* **2020**, *285*, 112787. [[CrossRef](#)]
46. Mitrovic, A.; Mathews, M.; Ohlsson, S.; Holland, J.; McKinlay, A. Computer-Based Post-Stroke Rehabilitation of Prospective Memory. *J. Appl. Res. Mem. Cogn.* **2016**, *5*, 204–214. [[CrossRef](#)]
47. Krokos, E.; Plaisant, C.; Varshney, A. Virtual memory palaces: Immersion aids recall. *Virtual Real.* **2019**, *23*, 1–15. [[CrossRef](#)]
48. Ventura, S.; Brivio, E.; Riva, G.; Baños, R.M. Immersive Versus Non-immersive Experience: Exploring the Feasibility of Memory Assessment through 360° Technology. *Front. Psychol.* **2019**, *10*, 2509. [[CrossRef](#)]
49. Corriveau Lecavalier, N.; Ouellet, É.; Boller, B.; Belleville, S. Use of immersive virtual reality to assess episodic memory: A validation study in older adults. *Neuropsychol. Rehabil.* **2018**, *30*, 462–480. [[CrossRef](#)]
50. Bréchet, L.; Mange, R.; Herbelin, B.; Theillaud, Q.; Gauthier, B.; Serino, A.; Blanke, O. First-person view of one’s body in immersive virtual reality: Influence on episodic memory. *PLoS ONE* **2019**, *14*, e0197763. [[CrossRef](#)]
51. Ouellet, E.; Boller, B.; Corriveau-Lecavalier, N.; Cloutier, S.; Belleville, S. The Virtual Shop: A new immersive virtual reality environment and scenario for the assessment of everyday memory. *J. Neurosci. Methods* **2018**, *303*, 126–135. [[CrossRef](#)] [[PubMed](#)]
52. Koné, Z. Adaptation of Mini Mental State Examination within a Population of Healthy Subjects in Mali: The Mamse. *Arch. Neurol. Neurosci.* **2019**, *4*, 1–8. [[CrossRef](#)]
53. Gonzalez-Landero, F.; García-Magariño, I.; Amariglio, R.E.; Lacuesta, R. Smart Cupboard for Assessing Memory in Home Environment. *Sensors* **2019**, *19*, 2552. [[CrossRef](#)] [[PubMed](#)]
54. Hampstead, B.M.; Sathian, K.; Moore, A.B.; Nalisnick, C.; Stringer, A.Y. Explicit memory training leads to improved memory for face–name pairs in patients with mild cognitive impairment: Results of a pilot investigation. *J. Int. Neuropsychol. Soc.* **2008**, *14*, 883–889. [[CrossRef](#)]

55. Cohen, J. *Statistical Power Analysis for the Behavioral Sciences*, 2nd ed.; Lawrence Erlbaum Associates: Hillsdale, NJ, USA, 1988.
56. Gil-Gómez, J.-A.; Manzano-Hernández, P.; Albiol-Pérez, S.; Aula-Valero, C.; Gil-Gómez, H.; Lozano, J.A. USEQ: A Short Questionnaire for Satisfaction Evaluation of Virtual Rehabilitation Systems. *Sensors* **2017**, *17*, 1589. [[CrossRef](#)]
57. Riva, G.; Alcañiz, M.; Anolli, L.; Bacchetta, M.; Baños, R.; Beltrame, F.; Botella, C.; Galimberti, C.; Gamberini, L.; Gaggioli, A.; et al. The VEPSY Updated Project: Virtual Reality in Clinical Psychology. *CyberPsychol. Behav.* **2001**, *4*, 449–455. [[CrossRef](#)]
58. Estévez-González, A.; García-Sánchez, C.; Junqué, C. Attention: A complex cerebral function. *Revista de Neurología* **1997**, *25*, 1989–1997.
59. Perry, R.J. Attention and executive deficits in Alzheimer's disease: A critical review. *Brain* **1999**, *122*, 383–404. [[CrossRef](#)]
60. Murray, A.M.; Nobre, A.C.; Stokes, M.G. Markers of preparatory attention predict visual short-term memory performance. *Neuropsychologia* **2011**, *49*, 1458–1465. [[CrossRef](#)]
61. Zhang, W.; Luck, S.J. Discrete fixed-resolution representations in visual working memory. *Nat. Cell Biol.* **2008**, *453*, 233–235. [[CrossRef](#)]
62. Matsukura, M.; Luck, S.J.; Vecera, S. Attention effects during visual short-term memory maintenance: Protection or prioritization? *Percept. Psychophys.* **2007**, *69*, 1422–1434. [[CrossRef](#)] [[PubMed](#)]
63. Regan, E.C.; Price, K.R. The frequency of occurrence and severity of side-effects of immersion virtual reality. *Aviat. Space Environ. Med.* **1994**, *65*, 527–530. [[PubMed](#)]
64. Hettinger, L.J.; Riccio, G.E. Visually Induced Motion Sickness in Virtual Environments. *Presence Teleoperators Virtual Environ.* **1992**, *1*, 306–310. [[CrossRef](#)]
65. García-Betances, R.I.; Jimenez-Mixco, V.; Arredondo, M.T.; Cabrera-Umpiérrez, M.F. Using Virtual Reality for Cognitive Training of the Elderly. *Am. J. Alzheimer's Dis. Other Dement.* **2014**, *30*, 49–54. [[CrossRef](#)]
66. Kang, Y.J.; Ku, J.; Han, K.; Kim, S.I.; Yu, T.W.; Lee, J.H.; Park, C. II Development and clinical trial of virtual reality-based cognitive assessment in people with stroke: Preliminary study. *Cyberpsychol. Behav.* **2008**, *11*, 329–339. [[CrossRef](#)]
67. Ericsson, K.A.; Chase, W.G.; Faloon, S. Acquisition of a Memory Skill. *Science* **1980**, *208*, 1181–1182. [[CrossRef](#)]

**Publisher's Note:** MDPI stays neutral with regard to jurisdictional claims in published maps and institutional affiliations.



© 2020 by the authors. Licensee MDPI, Basel, Switzerland. This article is an open access article distributed under the terms and conditions of the Creative Commons Attribution (CC BY) license (<http://creativecommons.org/licenses/by/4.0/>).

#### **IV. A Virtual Reality-Based Cognitive TeleRehabilitation System for Use in the COVID-19**

## Article

# A Virtual Reality-Based Cognitive Telerehabilitation System for Use in the COVID-19 Pandemic

José Varela-Aldás <sup>1,2,\*</sup>, Jorge Buele <sup>1,3</sup>, Pedro Ramos Lorente <sup>2</sup>, Iván García-Magariño <sup>4</sup> and Guillermo Palacios-Navarro <sup>2</sup>

<sup>1</sup> SISAu Research Group, Facultad de Ingeniería y Tecnologías de la Información y la Comunicación, Universidad Tecnológica Indoamérica, Ambato 180103, Ecuador; jorgebuele@uti.edu.ec

<sup>2</sup> Department of Electronic Engineering and Communications, University of Zaragoza, 44003 Teruel, Spain; pramos@unizar.es (P.R.L.); guillermo.palacios@unizar.es (G.P.-N.)

<sup>3</sup> Escuela Superior de Ingeniería y Tecnología, Universidad Internacional de la Rioja, 26006 Logroño, Spain

<sup>4</sup> Department of Software Engineering and Artificial Intelligence, Complutense University of Madrid, 28040 Madrid, Spain; igarciam@ucm.es

\* Correspondence: josevarela@uti.edu.ec

**Abstract:** The COVID-19 pandemic has changed people's lives and the way in which certain services are provided. Such changes are not uncommon in healthcare services and they will have to adapt to the new situation by increasing the number of services remotely offered. Limited mobility has resulted in interruption of treatments that traditionally have been administered through face-to-face modalities, especially those related to cognitive impairments. In this telerehabilitation approach, both the patient and the specialist physician enter a virtual reality (VR) environment where they can interact in real time through avatars. A spaced retrieval (SR) task is implemented in the system to analyze cognitive performance. An experimental group ( $n = 20$ ) performed the SR task in telerehabilitation mode, whereas a control group ( $n = 20$ ) performed the SR task through a traditional face-to-face mode. The obtained results showed that it is possible to carry out cognitive rehabilitation processes through a telerehabilitation modality in conjunction with VR. The cost-effectiveness of the system will also contribute to making healthcare systems more efficient, overcoming both geographical and temporal limitations.

**Keywords:** cognitive impairment; COVID-19; spaced retrieval; telerehabilitation; virtual reality



**Citation:** Varela-Aldás, J.; Buele, J.; Ramos Lorente, P.; García-Magariño, I.; Palacios-Navarro, G. A Virtual Reality-Based Cognitive Telerehabilitation System for Use in the COVID-19 Pandemic. *Sustainability* **2021**, *13*, 2183. <https://doi.org/10.3390/su13042183>

Academic Editor: Marc A. Rosen

Received: 26 January 2021

Accepted: 10 February 2021

Published: 18 February 2021

**Publisher's Note:** MDPI stays neutral with regard to jurisdictional claims in published maps and institutional affiliations.



**Copyright:** © 2021 by the authors. Licensee MDPI, Basel, Switzerland. This article is an open access article distributed under the terms and conditions of the Creative Commons Attribution (CC BY) license (<https://creativecommons.org/licenses/by/4.0/>).

## 1. Introduction

Comprehensive healthcare involves using the means and resources necessary to maintain people's health [1]. Technological progress has made it possible to improve these services, with examples including robotic surgery, liquid biopsy, portable sensors and telemedicine [2–4]. According to the World Health Organization (WHO), telemedicine is the provision of health services through the use of information and communication technologies (ICT) for the exchange of information between the health professional and the patient. The data obtained by using these interactive systems allow the prevention, diagnosis and treatment of diseases [5]. Technological development applied to medicine is linked to the widespread use of the Internet in public spaces, and most households admit that physical interaction is no longer mandatory [6]. The use of telemedicine should not replace the provision of conventional health services, but rather seeks to integrate them, making them more efficient and accessible to the user. All this should be done without neglecting the principles of confidentiality and professional ethics that should accompany any health practice [7,8]. However, as mentioned by Lawson et al. [9], innovations in the health sector must follow a rigorous testing process to validate their constant use in human beings. Several authors have made a comparison of the methodologies applied in telemedicine in contrast with the results obtained in conventional therapies, achieving good performance in the former [10,11].

Telemedicine offers remote monitoring, storage and delivery of clinical data and real-time interaction between physicians and patients [12]. This interaction is clearly seen in telerehabilitation, which provides rehabilitation services remotely in the patient's home or other chosen location [13]. Various types of technologies such as videos, computer programs or even live sessions can be used to guide the patient through the rehabilitation process [14]. In the beginning, the focus was on physical rehabilitation, achieving good results, which awakened interest in testing the effectiveness of rehabilitation on cognitive issues [15]. Namely, delirium (affecting consciousness, concentration and attention), amnesia (preceded by attention problems, disorientation and confusion) and dementia (where Alzheimer's is the most common disorder) [16].

The treatment of cognitive impairment varies according to the type of disease, the degree of severity and other factors specific to the person [17]. Whenever there is a progressive loss of memories, procedural memory rehabilitation symbolizes the basis for a successful therapy. This type of long-term memory will deteriorate the least in cases of dementia and other similar diseases [18]. A widely used neuropsychological rehabilitation technique in dementia is the spaced retrieval (SR) method [19]. This is a technique that consists of learning new information, which is retrieved continuously by increasing the time intervals between the evocations of such information.

This simple technique contributes to the rehabilitation processes of patients who present Parkinson's disease, Alzheimer's disease or brain injuries, promoting independence and close social interaction [20]. In fact, this technique has shown good results in Alzheimer's patients in different areas of memory, for example promoting retention of simple associations [21,22] or improving prospective memory [23,24]. It can be applied by any person (who does not have cognitive impairment) and it is based on the achievement of objectives, such as remembering family names, schedules and places. This is done with the premise that remembering information that is familiar to the patient involves less effort than when using new knowledge [25,26]. It should also be emphasized that in advanced stages of cognitive impairment, the technique is less effective. This rehabilitation technique and others require assessment and follow-up by the medical specialist, who must follow a plan, either in person or remotely, by using technological means or not. This article is organized as follows. Section 2 is devoted to the related work in the fields of telerehabilitation and VR application within the scope of the COVID-19 pandemic. Section 3 deals with the materials and methods used throughout the study, while Section 4 presents the results after the intervention, involving control and experimental groups. Finally, Section 5 presents the discussion and main conclusions of the study.

## 2. Related Work

As time goes by, patients' needs have become greater and more diverse. This is why telemedicine has been implemented in several health fields. The studies by Evans et al. [27] and Makhni et al. [28] introduced the use of robotics in the area of surgery (telerobotics), together with the identification of the advances and limitations. Another field of paramount importance deals with the training of health staff, of which the training of various skills and the practice of surgeries remotely are the most relevant aspects [29–31]. Telerehabilitation is also a topic of interest when dealing with children [32,33], young adults [34,35] and the elderly [36]. Especially the elderly, whose use is very limited because of physical discomfort and limitations in technology, should be highlighted. Telerehabilitation includes robotic assistance therapy [37], portable devices [38,39] and immersive systems [40], among others. The different techniques and devices used in the interventions have a high degree of acceptance and satisfaction among users, as shown in the review presented in [41].

The use of virtual reality (VR) in rehabilitation processes has been widely applied and the presence of this technology generates an added value in these processes [42]. VR has been used by physicians and researchers as a technological alternative that allows health procedures to be performed with new approaches and results in a safe environment. It also reduces the consumption of resources, avoiding unnecessary trips as an eco-friendly

measure. In addition, it offers the monitoring and delivery of immediate results, which allow evaluation of the evolution of the disease from quantitative and qualitative points of view through the application of tests [43]. All of these features (and more) have encouraged the use of VR in the treatment of different cognitive disorders [44]. In fact, the review carried out by Moreno et al. [45], which compiled 22 studies, showed that cognitive rehabilitation with VR generates improvements in memory and visual attention, as well as lowering levels of stress and anxiety. It is used in disorders such as neurocognitive disorders, patients with mild cognitive impairment or Alzheimer's disease. On the other hand, Park et al.'s work [46] presented 36 investigations that analyzed the use of VR in people with psychiatric disorders. It was identified that VR sessions are effective in treating anxiety, phobias and post-traumatic stress disorder (PTSD). Regarding the treatment of bipolar disorder, schizophrenia, depression, autism, and dementia, despite having positive results, further studies are required according to the authors.

VR has already been used for telerehabilitation of several diseases in recent years. Tieri et al. presented a review that highlighted the positive factors that an immersive environment provides to the patient during treatment [47]. On the other hand, Lindner et al. discussed the good results offered by VR in therapies to mitigate anxiety in public speaking as a support for health staff [48]. Likewise, the study by Isernia et al. [49] proposed telerehabilitation interventions for patients who had developed Alzheimer's disease to strengthen memory. Other post-stroke VR-based interventions have proven their efficiency compared to conventional therapies [15,50].

The COVID-19 pandemic has resulted in the social isolation of individuals, and thus the development of mental disorders [6]. In the study by Imperatori et al. [51], a brief review highlighted how VR applications have enabled specialists to provide therapy to patients. Mantovani et al. [6] provided an overview of how VR has contributed to cognitive telerehabilitation processes and the intensification triggered by this global health crisis. On the other hand, in [52], a multi-user virtual reality (MUVR) system was developed, in which the therapist interacts on a remote basis with patients with eating disorders. In the study, it is possible to identify how the user's dialogue with the psychotherapist's avatar (virtual environment) can reduce tension and stress during activities, instead of using a camera (videoconference). Although the participants did not know the therapists in person before, the real-time communication and virtual representation allowed confidence to develop throughout the sessions.

Internet access is becoming increasingly widespread and this fact has led to innovations in healthcare, offering greater benefits to the patient. The COVID-19 pandemic has encouraged the use of remote technological tools that allow a doctor-patient relationship to be maintained as closely as possible despite the distance. This is why a VR application for telerehabilitation has been developed, allowing interaction without any travel and replacing video conferences with a virtual environment. By doing so, the users will be able to gain access to rehabilitation programs in a safe manner and from the comfort of their homes.

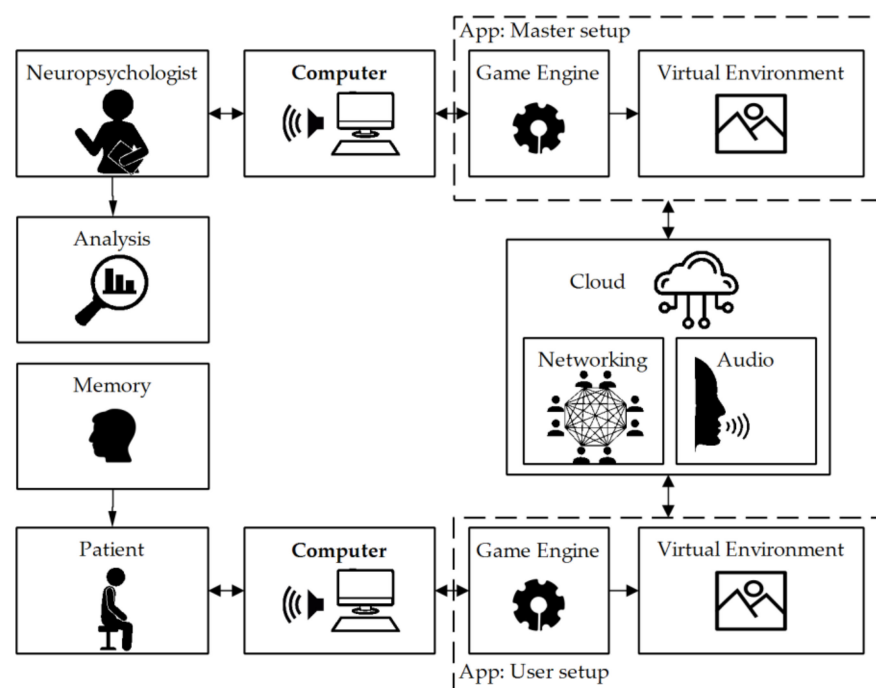
### 3. Materials and Methods

#### 3.1. Problem Statement

Telerehabilitation allows remote interaction between the patient and the medical specialist in order to share information and perform activities that improve the patient's condition through clinical therapy. Telecommunications and the Internet are vital in providing this service. Within the framework of the COVID-19 pandemic, it is important to reduce the contact between people as much as possible, creating room for the study of new proposals for telerehabilitation. Traditionally, telerehabilitation is carried out by using mobile communication technology or video call programs installed on personal computers. Although these tools allow for rapid interaction between users, there are limitations when sharing information and in data collection [53]. In neuropsychology, the specialist must present acoustic and visual information in the execution of cognitive activities, creating the



need for customized applications that include appropriate tools for remote rehabilitation. Specifically, in memory rehabilitation, the information presented must be retained by the patient according to the therapy needs, requiring applications with automated processes and visual richness that favor the patient's learning. In relation to the latter, VR offers flexible environments to execute neuropsychological rehabilitation tasks, which combined with multiplayer platforms allow users to interact online. The implementation of VR systems requires a display screen and input and output peripherals. Although there are several options available, as well as multiplatform video game engines, it is important to bear in mind the sustainability of the proposal. Thus, head-mounted display (HMD) devices are not appropriate because they are not common household devices, while mobile devices are limited by their screen dimensions. On the other hand, computers are still the most widely used large-screen devices at home, allowing for rapid installation of the proposed system. Figure 1 depicts the system proposed in this research, showing two opposite sides of the application; on one hand, the patient who must perform the cognitive exercises, while on the other hand, the therapist who must analyze the data generated in the cognitive therapy, with both users connected through computers. The application used provides different configurations for each user, so that the neuropsychologist is the administrator and has more privileges than the patient has as a user. This is because the master controls the information to be shown and decides the activities to be performed, although both users are in the same virtual environment. Network events and audio are transmitted using the cloud in a multiplayer platform that allows synchronized interaction.



**Figure 1.** Proposed system for cognitive telerehabilitation.

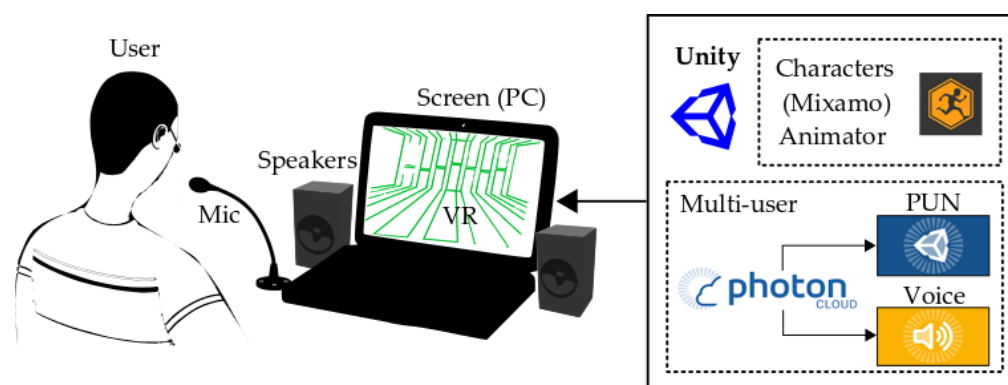
The proposal offers a VR multi-user application developed in a game engine, providing users with interactive elements for the process of cognitive rehabilitation by using the technique known as spaced retrieval. Through this technique, the neuropsychologist presents the information to be memorized and immediately asks the patient to identify the memorized elements (initial assessment). After this, the patient is distracted for a certain time with another activity, then again asked to retrieve the memorized elements (final assessment). These activities are performed within a virtual office, where the patient moves at will using a first-person view to provide an immersive experience and the administrator moves from a third-person view, taking greater control of the virtual environment. The movements take place using 3D characters (avatars), with animations programmed for

the actions performed by the user. The users are provided with voice communication to allow dialogue during the induction, rehabilitation and results processes. In addition, the patient's scores and response times are recorded in a file for later analysis. Finally, two groups of participants without neurodegenerative diseases are used to evaluate this system. The control group uses the conventional rehabilitation technique (face-to-face therapy) and the experimental group used the VR-based telerehabilitation application.

### 3.2. System Components

The system was designed for easy implementation in a standard home, so that users do not require specialized equipment or computer accessories that are difficult to install. In this context, personal computers (portable or non-portable) with Windows operating systems are the most used in the field of telerehabilitation. These devices generally include large screens and input–output devices, which are useful for interacting with the system. Regarding the development software, there are two highly popular options, namely Unity (San Francisco, CA, USA) and Unreal (Cary, NC, USA), both offering easy-to-learn engines and large support communities for application development. Based on these criteria, the system components for cognitive rehabilitation were defined.

Figure 2 shows the components required for the implementation of the system, whereby the computer monitor shows the virtual interface to the user and the audio is emitted through external or built-in speakers. The input elements (mouse, keyboard and microphone) allow interaction with the system. The selected game engine was Unity (Unity Technology, San Francisco, CA, USA), which allows the development of an application with both flexibility and multiplatform features. In addition, the proposal required three-dimensional animated characters or avatars, for which Mixamo was chosen. Mixamo is a web application that allows one to download prefabricated characters and avatar animations. As far as the multi-user platform is concerned, Unity works with Photon Cloud, a real-time interaction service that allows the synchronization of actions Photon Unity Networking (PUN) and communication by voice (Photon Voice).



**Figure 2.** Components of the multi-user system for cognitive telerehabilitation.

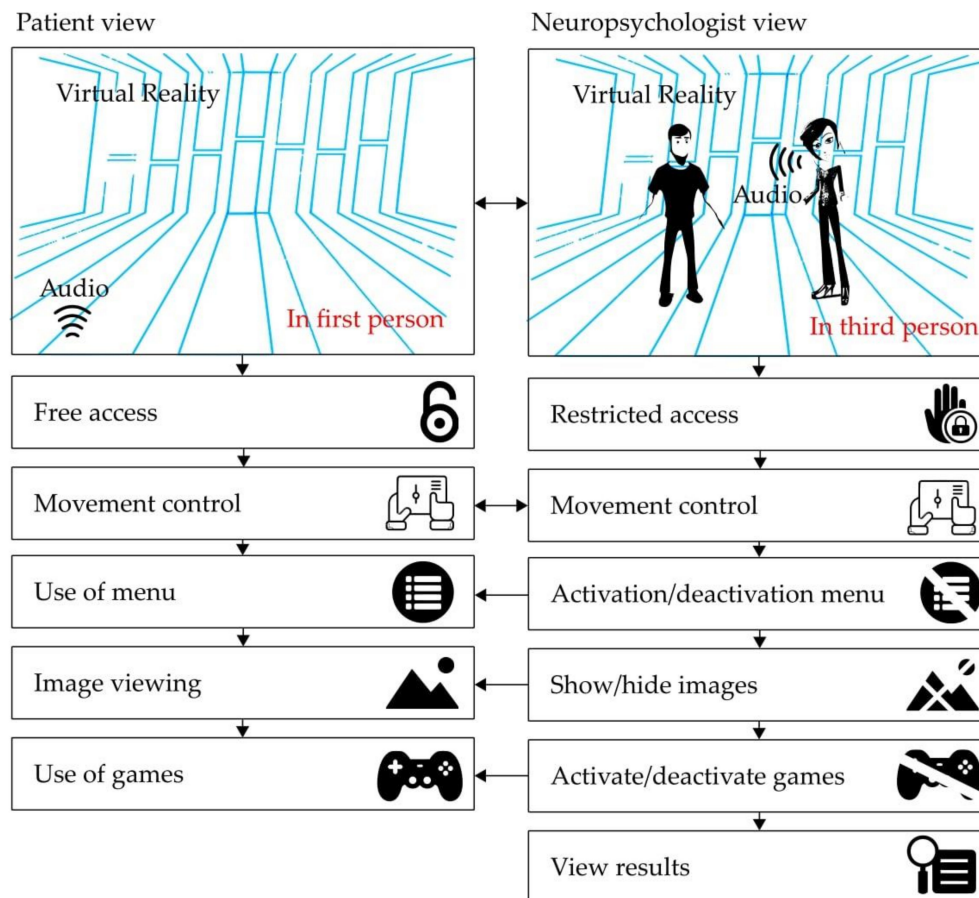
Internet connection is an essential requirement for the execution of the system, because the multi-user platform constantly exchanges information over the network to synchronize virtual environments and communicate with users. In addition, the results of the process are recorded in an open format file with CSV extension and then visualized in a simple spreadsheet. In the implementation of this proposal, no further software add-ons are required. On the other hand, the requirements regarding the user's knowledge include handling of screen devices and computer applications in general, and optionally some experience in VR or video games. Finally, although the patient experiences the virtual environment in first person, it is not necessary to restrict the system to users without motion sickness, because the immersion is minimal and the movements are gentle.

### 3.3. VR Application Design

There are several options to be implemented in the VR environment in the cognitive telerehabilitation process, but it is important to consider the simplicity of the tools for ease of use. The cognitive rehabilitation technique to be implemented was spaced retrieval [18], the strategy for which requires the presented information to be retained in the memory to observe the response to be observed immediately after (first assessment). After this, there is a sub-stage of error correction and reminder of the correct elements in the story, with the purpose of restarting the elements in the participant's memory. Then, the patient has to do extra activities for a certain period, aimed at distracting the participant. The time taken to perform this activity varies according to the patient and the decision of the specialist. For example, in healthy patients, it is common to wait between 10 and 20 min. After this period, the patient must again remember the elements recovered in the initial assessment. Each correctly remembered element is considered a success and each element not remembered is an error; selecting an incorrect element also results in an error. The entire procedure is performed within the virtual environment, using interactive tools to present information, distractions and response options, and with the control of the neuropsychologist at each stage.

The multiplayer system was designed for a maximum of two users at a time, with two independent roles. The patient role allows the virtual environment to be visualized in first person and the therapist role presents the environment in third person. A different configuration was established depending on the user role, so that the patient has less control of the system. Figure 3 summarizes the characteristics of each type of user role within the virtual environment. The first-person experience of the patient allows for a minimum level of immersion, while the user has the view from the player's position. In this way, the movements of the avatar in the VR environment are the main camera movements, although the patient can observe its avatar (patient role) for short periods of time when the movements are initiated. On the other hand, the neuropsychologist has a wider view of the virtual environment, visualizing the actions of both avatars and the elements that are incorporated into the scene in the rehabilitation process. Regarding the patient's attributes, the access to the main scene is free and the user can control the avatar's movements within the virtual environment, interact with the menus, visualize the images and use the games that are enabled. The privileges of the administrator are different, since this role has restricted access, which is secured by username and password. Once inside the main scene, they can freely control the movements of their avatar and can also activate and deactivate the menus, manage the visual information and the games within the scene experienced by the patient and of course visualize the results obtained by the patients.

The VR application consists of two user interaction scenes. The initial scene contains the start and configuration menus in two-dimensional format, where the player defines the access parameters before entering the virtual rehabilitation office. Then, the main scene contains the three-dimensional VR environment simulating a patient care office, where the telerehabilitation activities are performed and where users interact. Figure 4 shows the algorithm to be followed for the initial scene. It starts with a menu to select two available avatar choices: male or female. After this, the user selects their particular role (patient or neuropsychologist). If required, the user can return to the previous menu. Each role leads to a different access menu; in the patient role, the user only has to enter their name to access the next scene, whereas in the neuropsychologist role, the user must enter their name and password to gain access to the main scene. Whenever the input data are not correct, the user is prompted and cannot move on to the next scene until this is corrected. Once the user name is entered by the patient this is saved in a database.



**Figure 3.** Characteristics of user roles (patient and neuropsychologist) in the virtual reality (VR) application.

Figure 5 depicts the main algorithm scene. Once the VR environment has started up, the operating configurations are made according to the stored input data in the previous scene, the 3D VR models are loaded by applying the parameters according to the user role and subsequently avatars are instantiated. If the user enters when the scene is empty, only the local avatar is instantiated, otherwise both (local and remote) are instantiated. Once within the main scene, users can interact with the VR environment by moving around and talking to each other in order to become familiar with the system's features. When the rehabilitation process is about to start, both must be placed in the rest positions, sitting in their pre-established places, and then the neuropsychologist decides when to start. The information to be memorized is presented through audio and images and in video format played on a virtual screen within the environment. The video tells a short cartoon story with a duration of 2 min. The evaluation is performed through an option menu that contains 14 animals (7 of them appearing in the story), where the patient must select the right answers using the mouse. After this, the patient is distracted by a 3D game, where the user must solve mazes with different levels of difficulty; the number of mazes to be solved and their complexity depend on the therapist's criteria, which is set up beforehand. At this point a second evaluation is performed (final assessment). Both response accuracy and reaction times are saved in a database in a compatible spreadsheet format and the neuropsychologist can open the file when required. At any time, the administrator (neuropsychologist role) can stop, restart or repeat any of these rehabilitation processes if they consider it necessary.

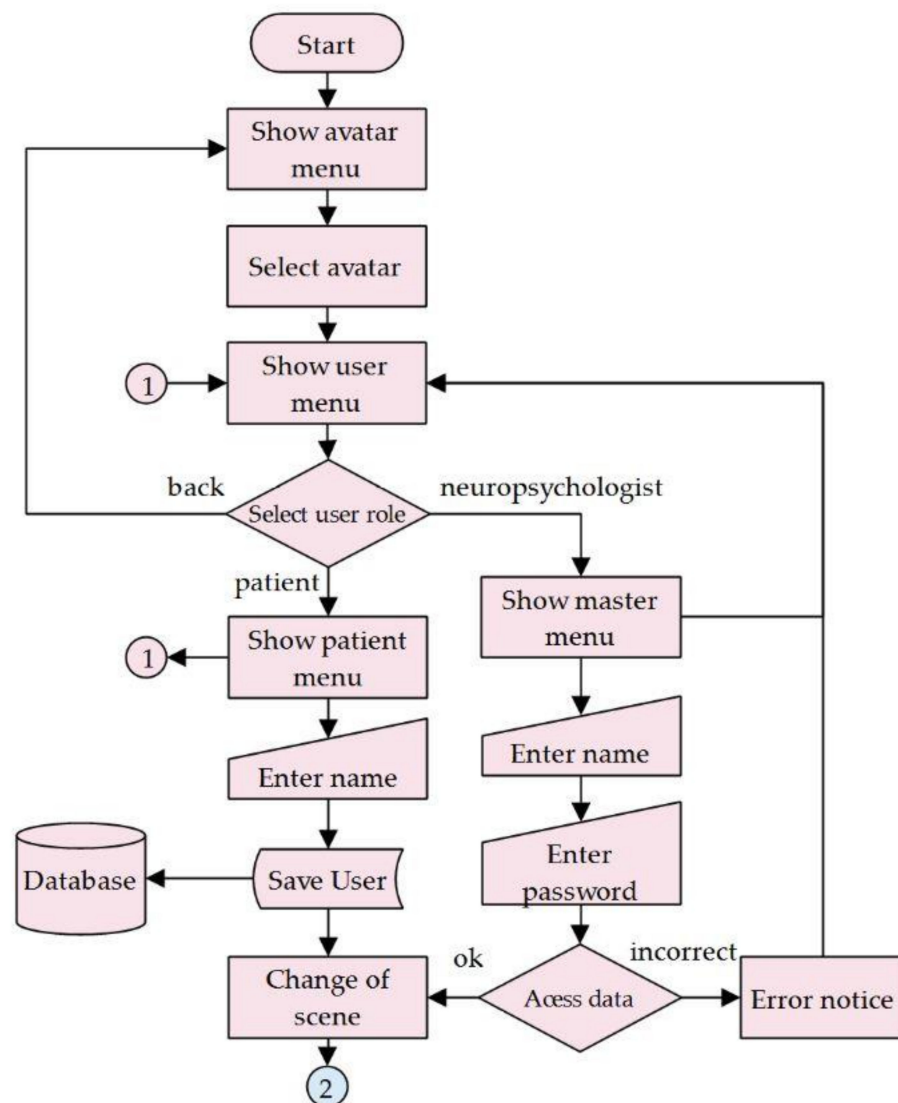


Figure 4. Initial scene algorithm in the VR application.

### 3.4. Development of the VR Environment

To develop the application, two computer software programs were used—Mixamo for the avatar animations and Unity to create the VR environment and execute the routines designed for the system. Figure 6 shows the general diagram developed in the Unity game engine, highlighting three main components: game objects, scripts and hardware. Unity's scenes mainly contain the elements that make VR possible, namely game objects that allow the creation of lights, cameras, 3D models, avatars and other objects. In this application, the game objects are the user avatars, 3D models, menus and audio components. To complete the VR rehabilitation office, some other elements were created with the basic tools in Unity and certain 3D models imported from the Asset Store. On the other hand, the scripts are the software that control the actions within Unity's scenes, which allow animations, activating menus, save files and many more functions to be shown. Within the system, the scripts are in charge of linking the hardware inputs with the avatars' movements and the application tasks; they enable game objects, play audio and video and generate the results. In addition, the scripts contain the sentences of the multiplayer functions, updating the actions for both user roles and sending the voice audio. The hardware connected to the application is the computer monitor, the input peripherals (mouse and keyboard) and input and output audio devices (speaker and microphone).

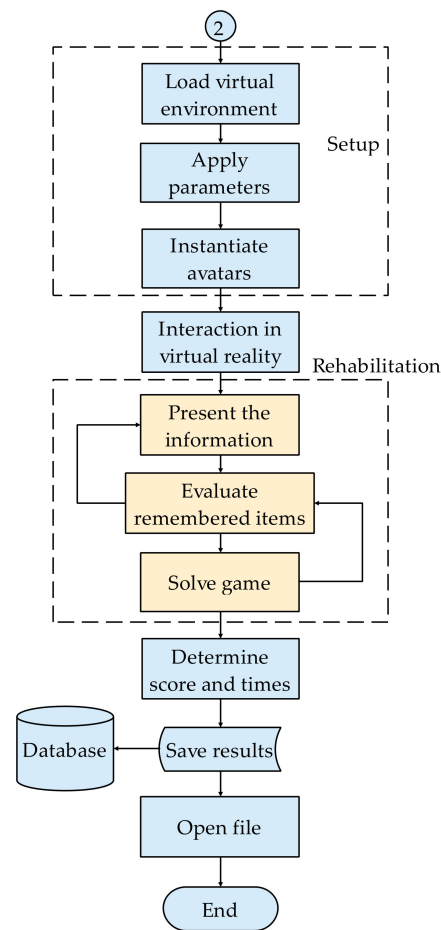


Figure 5. Main algorithm scene in the VR application.

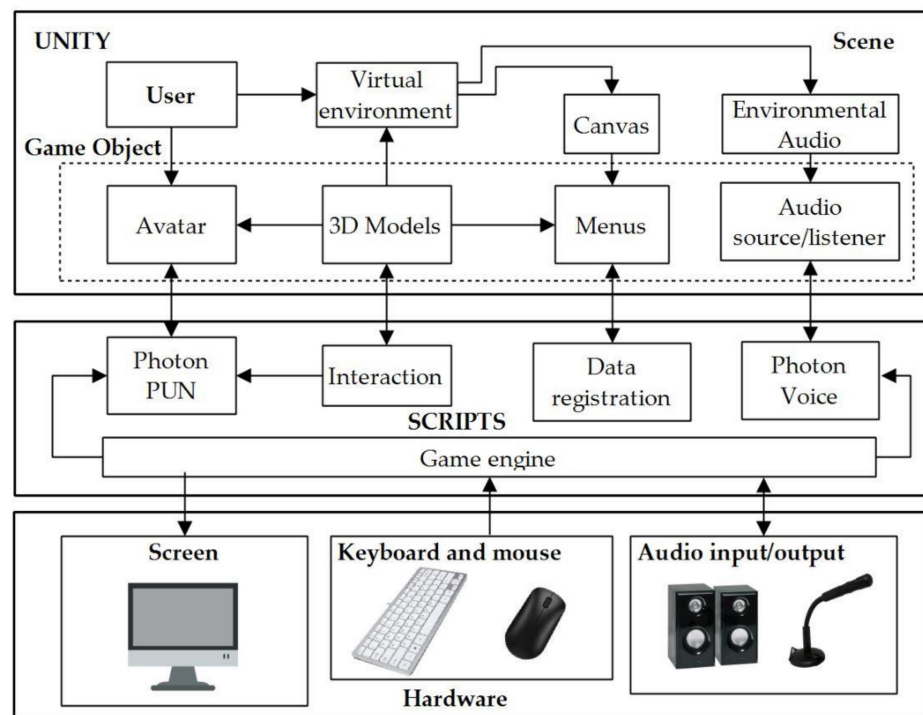


Figure 6. General diagram of the VR application (developed using Unity).

The avatars and multiuser features were developed in stages, as shown in Figure 7. The first stage involved downloading the avatars, animations and textures for the 3D model assembly via the Mixamo website. The objects were dragged into the game engine for the next stage. In the second phase, the avatars and animations were incorporated into the Unity environment, where the avatar game object was inserted into the scene and an animator controller was built. The animation controller allows combinations of movements to be added in the form of blocks of states connected through transitions. The control inputs were configured using parameters and a tree of combinations that regulate the type and speed of the animation. In addition, a special transition was inserted to adopt the sitting position (used to perform rehabilitation), imitating a real therapy session. The final stage of development included the programming of the scripts (C#) and the configurations of the objects in scene. In order to interact realistically with the environment, a capsule collider and a rigid body were added to the avatar, with the rest of objects maintained with colliders. Two scripts (for the avatar) are in charge of locomotion and camera tracking. The locomotion is performed kinematically using the *transform.Rotate* and *transform.Translate* commands and is controlled with the keyboard arrow keys (*Input.GetAxis*). Camera tracking is performed by modifying the states of the main camera in the scene through the *camera.position* and *camera.LookAt* commands, and the parameters for this script depend on the selected user role (first-person and third-person options available). In addition, pressing the space bar on the keyboard activates the transition so that the user takes a seat in the preset furniture according to the type of user role. Then, regardless of the position of the avatar, they walk to the destination and take a seat.

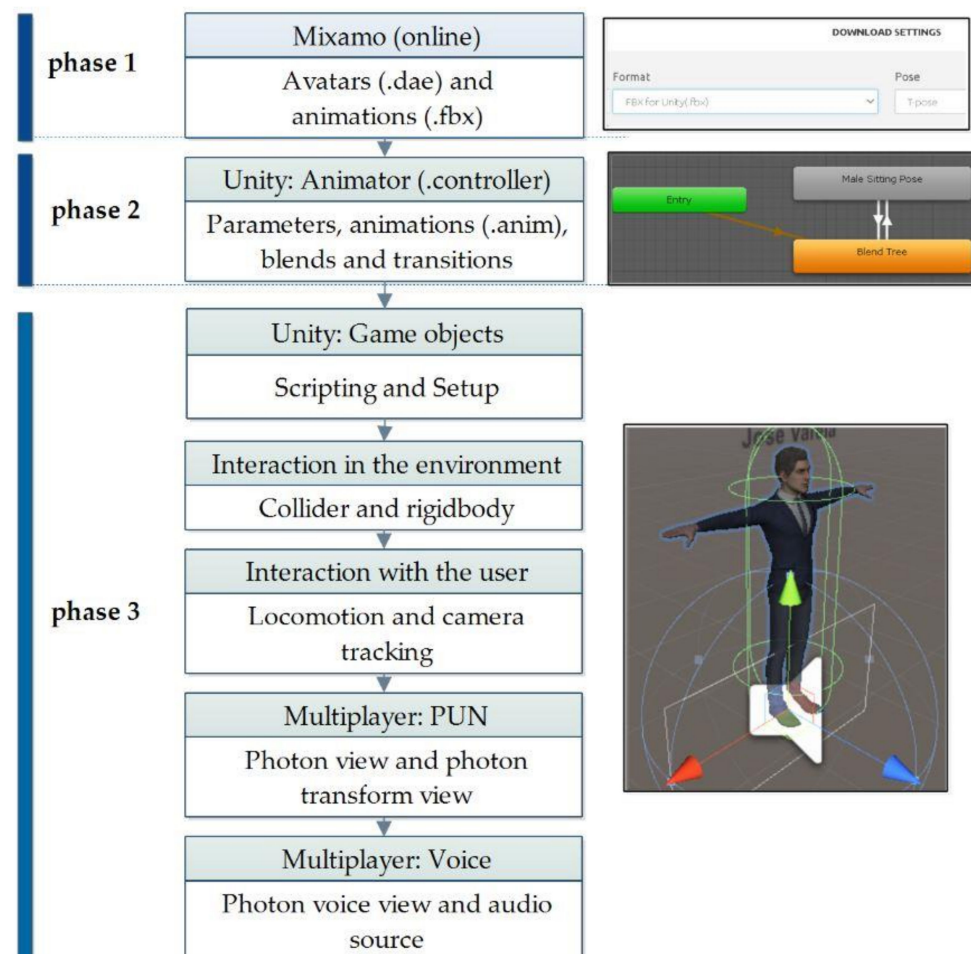


Figure 7. Development stages in the implementation of the VR application.

The scripts also contain the multiplayer actions implemented using the Photon Unity Networking (PUN) library. To load the main scene in the local and remote stations, a room in the Photon network is created using the command *PhotonNetwork.JoinOrCreateRoom*. The avatar is then instantiated using *PhotonNetwork.Instantiate*, so that all connected users appear in the application. The multiplayer configuration requires all game objects to be updated by PhotonNetwork with the script component called Photon View, which assigns an in-game ID and allows the basic states in all running applications to be modified. Additionally, each avatar must contain the Photon Transform View component, which synchronizes the movements performed by the user, so that they are displayed in all open applications. The update of the states via the menus, avatar animations and the maze game is done through remote procedure calls (RPCs). On the other hand, the movements controlled by the user only trigger the corresponding avatar by means of the *photonView.IsMine* command (a true value guarantees the execution only on the assigned avatar). Finally, the voice chat is installed for the avatar by means of the Photon Voice View and Speaker script components of the Photon Voice add-on, together with an audio source (within the Unity engine). This allows the remote user's audio to be played for verbal communication.

The scenes of the application were implemented and evaluated by the developers in search of improvements related to usability and errors, so as to improve system function. Figure 8 shows screenshots of the user interface in the initial scene, which is presented prior to the start of the main scene and allows basic user information to be collected, such as the avatar gender and the user role. In the patient role menu, there is only one input field, which allows the entered name to be registered in the system via keyboard. In the case of the neuropsychologist role, there are two input fields to be completed, the name and password. Finally, the "back" button allows the user to go back to the different menus and the "start" button loads the main VR scene.

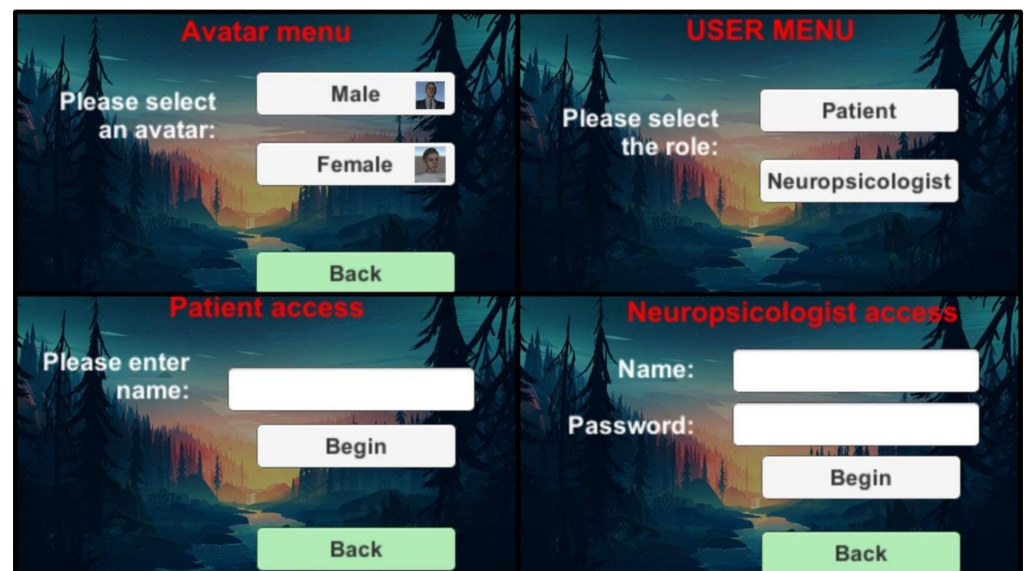


Figure 8. Screenshots of the implemented menus in the VR application (initial scene).

Figure 9 depicts the implemented VR environment from the patient's view. The images show the first-person screenshots with the elements of the virtual office: the video screen tells the story, the maze game is to be solved by the patient and the answers option menu is used for the memory assessment. The VR space contains armchairs, vases and wall paintings, with a large area of  $9 \times 7$  square meters for the avatars to move around. A label appears above the avatar, whose text is taken from the initial scene (to facilitate communication when talking to another person). The audio and video playback screen appears only when the neuropsychologist enables it and disappears in the same way or at



the end of the playback. The maze game is solved by taking out the sphere through the only existing exit, for which the user uses the directional keys on the keyboard. The evaluation menu is completed using the mouse to select the answers that the patient considers correct; once the evaluation is completed, the administrator (neuropsychologist role) disables this menu, saving the answers. On the other hand, Figure 10 shows the VR environment from the neuropsychologist's view, observing the avatars in third person and with the presence of the administrator menu, which is shown and hidden by pressing the letter "m" on the keyboard and is only available for this user role. The available options are: video playback, generation of the maze with the desired level of difficulty and patient evaluation. Should the results not be generated, the option to open results does not appear. In this case, the spreadsheet (.csv format) containing the following results is opened: number of successes, number of failures and response times of the first assessment; the same also occurs for the second assessment, which is performed after the distraction period.

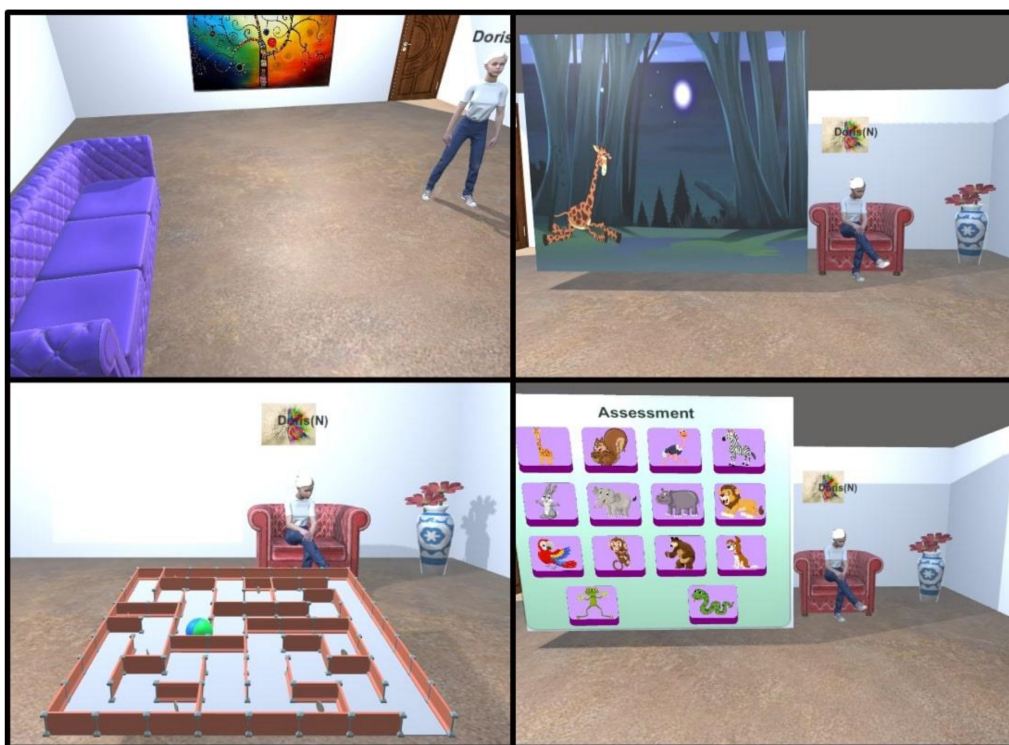
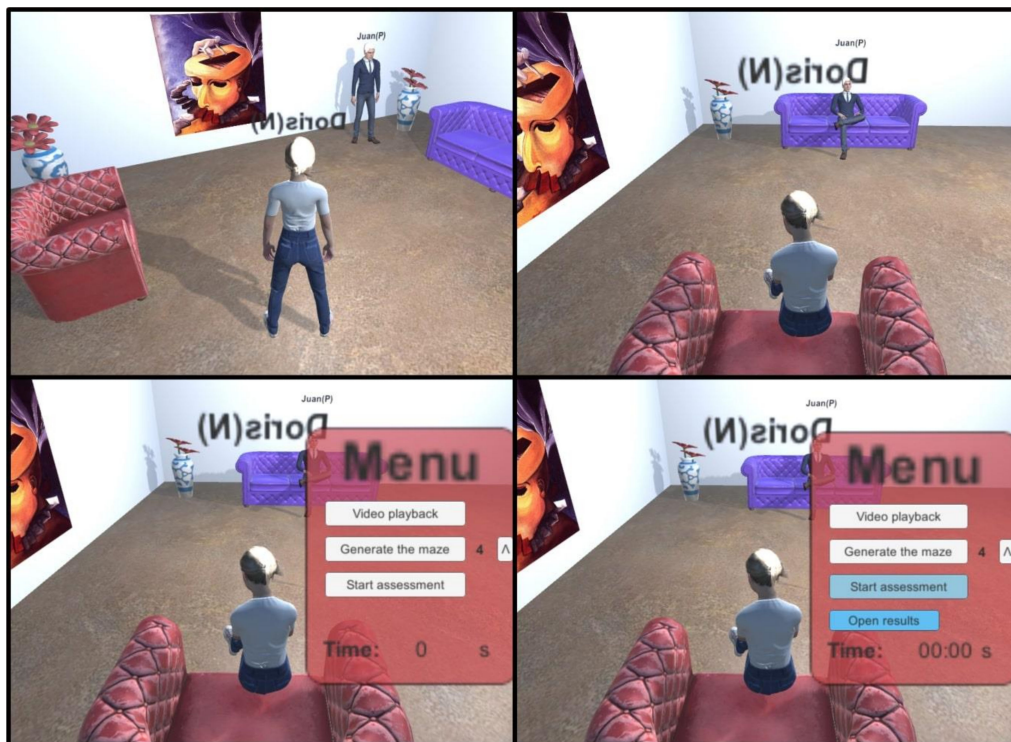


Figure 9. Screenshots of the main scene in the VR application (first-person view—patient mode).

### 3.5. Statistical Analysis

Statistical analysis was carried out using SPSS 16. Student *t*-tests were used to check for differences in age and years of education between the groups at baseline, while Pearson's Chi-squared test was used to verify the homogeneity between groups in terms of gender. The analysis of the obtained results after the intervention was performed using repeated measures ANOVA with between-subject (intervention: control vs. experimental) and within-subject factors (accuracy response: initial vs. final assessment). A paired *t*-test was performed to check for differences in reaction times in the experimental group, whereas Pearson's correlation was used to infer any association between reaction times and age, gender and years of education, respectively. Finally, the experimental group completed a usability test to measure the level of acceptance of the system's features. The statistical significance level was set to 0.05.



**Figure 10.** Screenshots of the main scene in the VR application (third-person view—neuropsychologist mode).

### 3.6. Participants

Two groups of participants were used for this research. The experimental group performed the tasks via the VR application and the control group performed the tasks following a conventional therapy approach by using printed materials in face-to-face mode. All participants signed an informed consent form prior to their participation in the research. The activities in the experimental group started with the installation of the VR application in the computer, followed by a phase to gain familiarity with the application (via video calls with the researchers), but without performing any rehabilitation activity. Participants were only recruited into the experimental group if they had some experience in handling computer applications. Table 1 details the demographics of the participants, consisting of 20 people in each group with members of both genders and with ages ranging between 18 and 65 years. Regarding the experimental group participants, 45% of this group were women, 50% had experience with VR or video games, 25% had a family history of neurodegenerative diseases and 60% used to performed cognitive activities on a regular basis. The average age was 32 years, with a standard deviation (SD) of 11 years, while the average level of education was 16 years, with an SD of 3.6 years. On the other hand, the control group contained 50% women, 20% of the participants had a family history of neurodegenerative diseases and 55% of the participants performed cognitive activities on a regular basis. The average age of the group was 35 years, with an SD of 13 years, while the average level of education was 14 years, with an SD of 4.9 years. No significant differences were found by gender ( $p = 0.525$ ), age ( $p = 0.543$ ) or years of education ( $p = 0.094$ ) between the groups.

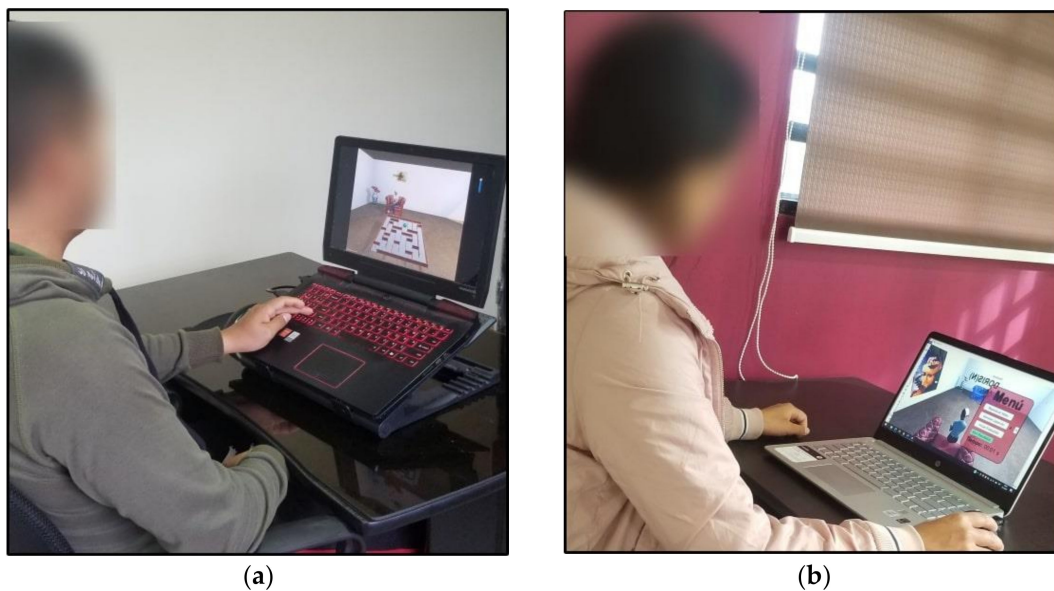
**Table 1.** Participant demographics.

Variable		Experimental Group	Control Group
Gender	Male	9	10
	Female	11	10
Age	Mean	32	35
	SD	11	13
Experience VR	Yes	10	0
	No	10	20
Education (in years)	Mean	16	14
	SD	3.6	4.9
Family history	Yes	5	4
	No	15	16
Cognitive exercise	Yes	12	11
	No	8	9

## 4. Results

### 4.1. Experimentation

The data were obtained from the participants belonging to both groups: the control group and experimental group. The latter group also undertook usability tests after the completion of the task. Figure 11 shows two users interacting with the application. The patient is solving a maze (Figure 11a) and the neuropsychologist is interacting with the main menu (Figure 11b). The system was used by 20 healthy patients and a neuropsychologist who conducted the cognitive rehabilitation procedure.

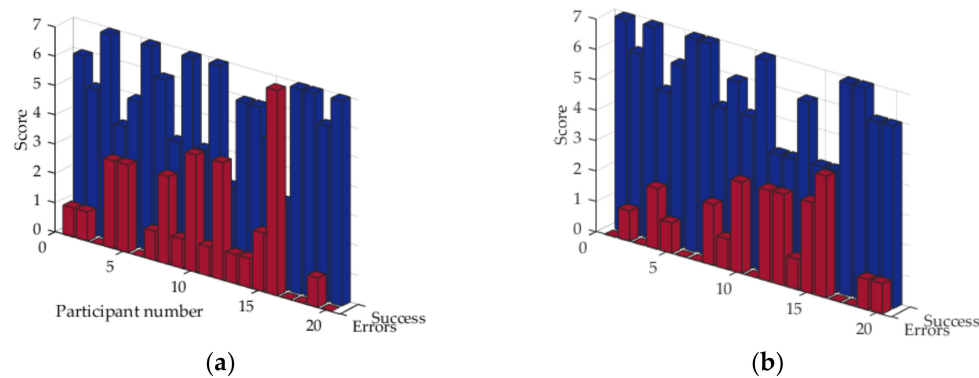


**Figure 11.** VR application evaluation: (a) user of application performing the patient role; (b) user of application performing the neuropsychologist role.

#### 4.1.1. Face-to-Face Mode

The control group performs only face-to-face rehabilitation using the spaced recovery technique, with physical materials such as printed sheets, a pencil and an eraser. The neuropsychologist begun by requesting written consent and explaining the processes to be performed. Then, a story was told with images and verbal descriptions immediately after the initial evaluation was performed. Figure 12a shows the results of the initial evaluation (immediate memory) for the 20 participants, with an average accuracy rate of

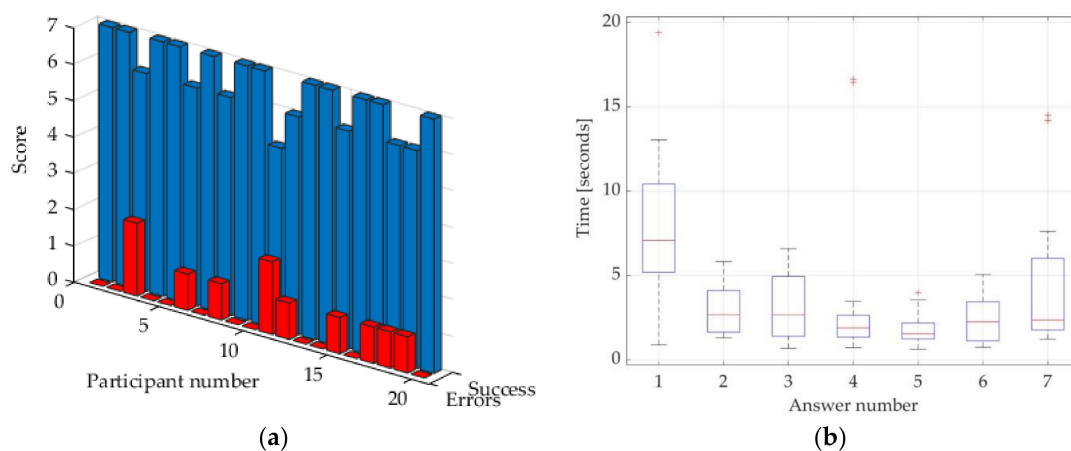
5.6/7 (80%) and an average error rate of 1.7/7 (24.3%), the latter corresponding to forgotten or erroneous elements. The next step dealt with the distraction stage, where the patient performed cognitive activities, solving printed mazes for a period of 20 min. The final evaluation dealt with the identification of the elements remembered after this period of time, with an average accuracy rate of 4.8/7 (68.6%) and an average error rate of 1.3/7 (18.6%). The results are shown in Figure 12b. A decrease of 11.4% in the accuracy response rates between the initial and final evaluations can be seen.



**Figure 12.** Results of the final assessment for the control group (face-to-face rehabilitation): (a) initial assessment scores; (b) final assessment scores.

#### 4.1.2. Telerehabilitation Mode

Experimentation in the VR application had one more stage in comparison to the face-to-face modality because the 20 participants had to learn to use the system prior to telerehabilitation. The usability of the application was subsequently evaluated. The results of the application were automatically determined, showing a 6.55/7 (94%) success rate and 0.55/7 (8%) error rate in the initial evaluation (Figure 13a), with better scores than those obtained in the face-to-face modality. The system also offers the reaction and response times for each correct element of the evaluation menu. Taking into account that only seven answers were correct, the median times (seconds) obtained were 7.07, 2.65, 2.65, 1.88, 1.53, 2.25, and 2.35, respectively, as shown in Figure 13b. The average response time was 3.74 s, with some outliers.



**Figure 13.** Results of the initial assessment for the experimental group: (a) accuracy and error response rates; (b) reaction times.

The results of the final assessment (spaced retrieval) only showed a few mistakes (2% in all tests), with an accuracy response rate of 98% (Figure 14a). Therefore, the performance was better than that obtained for the face-to-face modality (on average). As far as the final

evaluation response times were concerned, the following median times (seconds) were obtained: 3.3, 1.69, 1.75, 1.32, 1.43, 1.65, and 2.16 for correct items, with an average response time of 2.21 s. These values were lower (on average) than those obtained in the initial evaluation and there were also outliers.

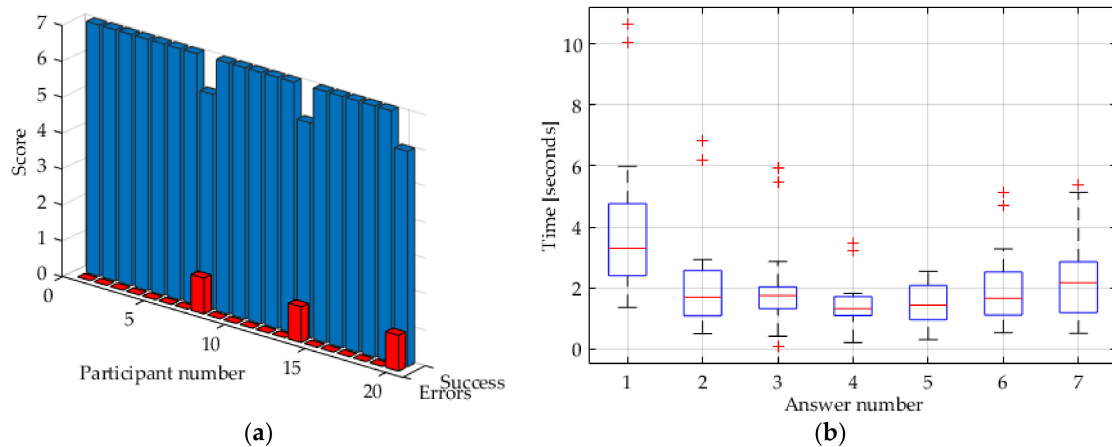


Figure 14. Results of the final assessment for the experimental group: (a) accuracy and error response rates; (b) reaction times.

#### 4.2. Comparative Analyses between and within Groups

The results for the accuracy response rates showed significant differences between groups ( $F(1, 38) = 12.95, p = 0.001$ ) in favor of the experimental group (telerehab group). In the comparisons within groups, the results did not show a significant difference over time ( $p = 0.061$ ) or in the interaction effect between factors ( $p = 0.701$ ). Figure 15 depicts the accuracy response rates (mean scores) for both the initial and final assessments and the group variable. Concerning the response times taken to accomplish the tasks within the experimental group, the average time spent in the final evaluation of the test was significantly lower ( $p = 0.001$ ) ( $M = 15.28, SD = 4.61$  for the final evaluation versus  $M = 25.87, SD = 12.05$  for the initial evaluation). On the other hand, there was no association ( $p > 0.05$ ) between response times and age ( $p = 0.175$ , initial assessment,  $p = 0.184$ , final assessment), gender ( $p = 0.352$ , initial assessment,  $p = 0.376$ , final assessment) or years of education ( $p = 0.361$ , initial assessment,  $p = 0.406$ , final assessment) in any of the assessments.

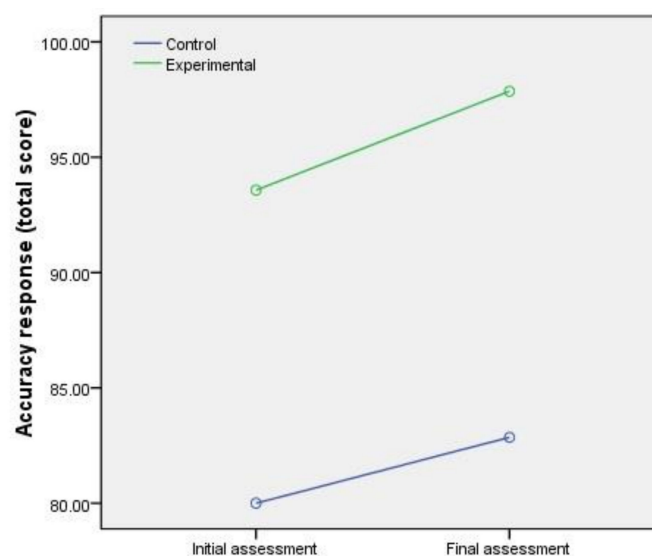


Figure 15. Estimated marginal means for accuracy response scores for the Space Retrieval (SR) task.

#### 4.3. Usability Analysis

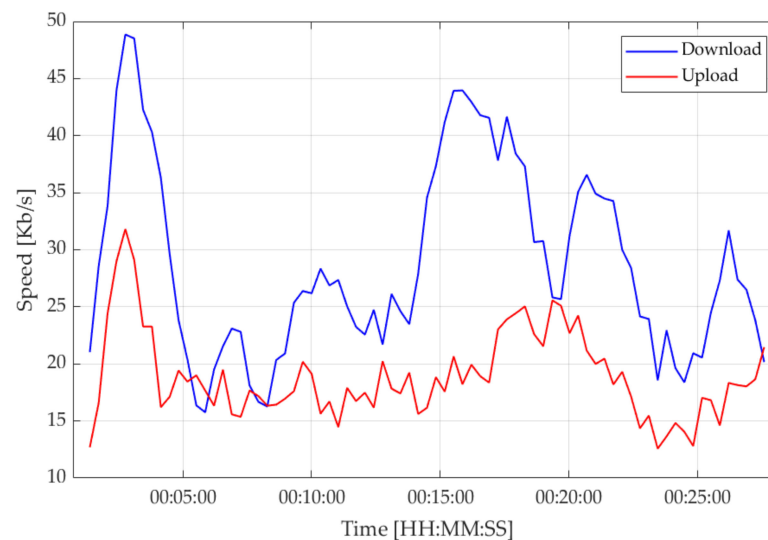
The usability analysis for any application is very important, and in this case even more so since a potential target group for cognitive rehabilitation is the elderly population. The system must have a sufficient degree of usability to avoid interaction difficulties, especially in this elderly group. The designed application, besides being as simple as possible, must also have a high degree of usability. To evaluate the usability of our system, we have used the suitability evaluation questionnaire (SEQ) test described in [54]. The instrument as designed to evaluate VR applications in rehabilitation activities. The test consists of 14 questions, comprising 13 closed-response items (Q1–Q13) and one item with an open-response option (Q14: “If you felt uncomfortable during the task, please indicate the reasons”). The closed-answer questions were assigned based on Likert scales, and the scores obtained for questions Q1, Q2, Q3, Q4, Q5, Q6 and Q11 were directly used for the overall score, whereas the scores obtained for questions Q7, Q8, Q9, Q10, Q12 and Q13 were processed by subtracting them from 6 (6-Qi). The questionnaire was given to the 20 participants after use of the VR application, the results for which are shown in Table 2. The overall score of 59.65/65 (91.77%) indicated the high usability of the system, with very low standard deviation (SD), denoting minimal difference in criteria. On the other hand, the lowest score was obtained for Q2, showing that immersion in the virtual environment was limited (it is a non-immersive system). With respect to Q14 (related to task discomfort), no participant reported any related discomfort.

**Table 2.** Usability test results ( $n = 20$ ).

Question	Mean	SD
Q1. How much did you enjoy your experience with the system?	4.65	0.45
Q2. How much did you feel you were in the environment of the system?	3.55	0.57
Q3. How successful were you in the system?	4.70	0.46
Q4. To what extent were you able to control the system?	4.40	0.80
Q5. How real is the virtual environment of the system?	4.20	0.87
Q6. Is the information provided by the system clear?	5.00	0.00
Q7. Did you feel discomfort during your experience with the system?	1.10	0.30
Q8. Did you experience dizziness or nausea during your practice with the system?	1.00	0.00
Q9. Did you experience eye discomfort during your practice with the system?	1.10	0.30
Q10. Did you feel confused or disoriented during your experience with the system?	1.40	0.49
Q11. Do you think that this system will be helpful for your rehabilitation?	4.65	0.63
Q12. Did you find the task difficult?	1.40	0.66
Q13. Did you find the devices of the system difficult to use?	1.50	0.67
<b>Total</b>	<b>59.65</b>	<b>0.48</b>

#### 4.4. Bandwidth Requirements

The online multi-user application may be limited by network requirements, so we analyzed the bandwidth requirements for a suitable level of function for the VR application. The communication between users involves the exchange of two types of data: the synchronization of movements and actions within the VR environment and conversation through voice. Figure 16 depicts the transmission rates in a common SR-based rehabilitation session that lasted 27 min and 30 s. A sampling rate of 15 s was used and transmission rates are shown in kilobytes per second (Kb/s). The download rate showed a minimum of 15.8 Kb/s, a maximum of 48.9 Kb/s and an average of 28.8 Kb/s. For upload rates, there was a minimum of 12.6 Kb/s, a maximum of 31.8 Kb/s and an average of 17.5 Kb/s. In general, very low transmission speeds were observed during normal operation due to the optimized performance of Photon Cloud, which synchronizes the two virtual environments through state updates, such as for positions, rotations, instructions and activations (without images), together with the exchange of voice data. In summary, the bandwidth requirements are very low and transmission rates ensure that this cognitive telerehabilitation approach can be applied in all households with a simple internet connection.



**Figure 16.** Transmission rates during a common SR-based telerehabilitation session.

## 5. Discussion and Conclusions

The objective of cognitive rehabilitation is to compensate for or repair certain cognitive functions that have been impaired by either age-related changes or a specific medical condition. The use of technology has made it possible to migrate those processes that were previously performed manually into computer-developed interfaces. The implementation of VR environments in the treatment of cognitive diseases has been taking place in recent years as a new alternative to conventional procedures [55,56]. VR therapy has been tested to improve cognitive abilities in people suffering from Alzheimer’s disease, Parkinson’s disease, trauma or after a stroke, among others [6,49,57]. Similarly, other psychiatric pathologies have been treated, as well as dementia, eating disorders and phobias [46,52,58].

Undoubtedly, VR-based interventions have been especially numerous in the cognitive rehabilitation of Alzheimer’s patients, providing satisfactory results, although the long-term effects are not yet fully known [57,59,60]. However, these sessions are usually administered face-to-face and the use of telerehabilitation is relatively new for the treatment of this disease [49]. Something similar occurs in post-stroke treatment, whereby the application of VR has already been widely developed [37,40,42], however remote assessment is more recent [9,15,50]. This shows that the application of VR in telerehabilitation is a new trend, the implementation of which has been accelerated by the COVID-19 pandemic. It is important to highlight that in synchronous sessions (real-time) a high interaction is achieved, while in asynchronous sessions this depends on the patient’s commitment [58].

In this work, we have developed a VR-based system that allows effective interaction between the patient and the specialist physician for cognitive rehabilitation purposes. We have implemented the spaced retrieval method for cognitive rehabilitation, a technique that had previously only been applied manually [20,25,26], but has now been digitized through the use of immersive environments. The system makes it possible to evaluate the patient’s ability to retain information over time. The results of our study, validated with healthy subjects aged 18 to 65 years and without diagnosed cognitive problems, show that it is possible to perform telerehabilitation or cognitive training with the help of virtual-reality-based applications. In fact, according to the assessments in the designed task, it should be noted that in both the initial and final assessments, there were significant differences in favor of the experimental group (telerehab group). In line with our study, Meltzer et al. compared a tablet-based telerehabilitation treatment with a face-to-face treatment for a total of 44 adults with communication disorders after stroke. They obtained statistically equivalent gains between the face-to-face and telerehabilitation groups for most of the tests used [61]. We can find another example in the study by van der Linden et al. [62], who developed an iPad-based cognitive telerehabilitation program for patients

with primary brain tumors based on previously evaluated face-to-face cognitive programs. They demonstrated its feasibility through measures such as adherence, attrition, accrual and patient experience.

This leads us to believe that not only are both cognitive training systems equivalent (face-to-face versus remote), but that the participants achieved better success rates in the two evaluations of the spaced retrieval task. This slight improvement in scores in the experimental group may have been due to greater focus on the activity and the memorized items being presented in an engaging environment within the VR setting. The adoption of a telerehabilitation system such as the one developed in this work promotes a series of clearly positive factors in cognitive rehabilitation, such as the possibility of more intense treatments, repeatability, the promotion of engagement, as well as the ability to transfer cognitive skills to the real world, as pointed out by Mantovani et al [6]. In addition, the proposed system acquires the user's response times, information that is relevant for the patient's cognitive analysis.

According to the results obtained in the usability test, we can state that the application helps in performing pleasant rehabilitation sessions in the same way that conventional therapies do. However, the results need to be validated with additional tasks that demand greater attention and cognitive effort. Although our study was a quasi-experimental and controlled design with a reasonable number of subjects, it would be desirable to validate the system with patients suffering from certain types of neurodegenerative disease, such as Alzheimer's disease (AD). In our favor, recent studies have pointed out important improvements in the cognitive rehabilitation of this population, such as the study conducted by Small and Cochrane [63], where interventions with SR helped to maintain the functioning of recent episodic memory. The study by Hawley and Cherry [64] showed that the training with the SR technique had a positive influence in the recall of simple face-name associations.

We have created a framework with which to meet future needs in the field and that can be used by healthcare staff to promote cognitive telerehabilitation. Within this framework processes can be automated, therefore allowing data collection in real time for subsequent analysis and decision-making. At the same time, social distancing measures due to the COVID-19 pandemic are promoted, increasing the safety of patients who can access rehabilitation services from the comfort of their homes. The advantages that our system provides (simplicity of use, high usability and cost-effectiveness, among others) are clearly in line with making healthcare systems more efficient and overcoming geographical limitations (for examples in areas that are difficult to access or areas with limited health services) and temporal limitations (reduction of waiting times). In the same way, it allows patients with reduced mobility to access healthcare professionals. For the above reasons, and due to the resource savings it offers, we can state that our approach is also environmentally friendly.

The design of this system was influenced by the great restrictions and difficulties inherent to the COVID-19 pandemic, such as reduced patient mobility, overrun health services and difficulties in carrying out community-based interventions. The fact is that the lessons learned from the COVID-19 pandemic have served to develop new technological advances, which are here to stay and will certainly be used in the future, even after the end of the pandemic [6]. In anticipation of future pandemics that may significantly affect our everyday life, the implementation of such approaches in the field of cognitive rehabilitation will undoubtedly help health systems to improve their efficiency in terms of the use of resources and time, to increase their productivity, and above all, patients may benefit from these telerehabilitation programs.

In future work, the authors of this research propose several lines of action. First, the developed system should be validated with patients with both mild and moderate cognitive impairment, for example patients suffering from Alzheimer's disease. Evidently, it will be necessary to include spaced retrieval tasks that demand a little more attention and effort in order to find contrastable evidence. Similarly, a usability evaluation will have to be taken into account, as this is critical when working with users who have specific



needs [65]. This evaluation should be performed in the design stages of the application, considering the execution time, level of immersion, comfort and possible adverse side effects on the participant. On the other hand, certain autonomous rehabilitation activities could also be added to the application that would allow users to train memory function without the need for a specialist physician and without removing the multiuser features that characterize this proposal. Finally, an important aspect that should be addressed in the case of discharged COVID-19 patients is the study of the different recovery trajectories through multidisciplinary telerehabilitation programs, in line with what Salawu et al. pointed out in their study [66]. In fact, the developed tool allows the implementation of a multidisciplinary telerehabilitation program that encompasses the different post-COVID 19 sequelae, such as psychological issues, cognitive disorders, physical problems and speech and language disorders.

**Author Contributions:** Conceptualization, G.P.-N., P.R.L. and I.G.-M.; methodology, G.P.-N., J.V.-A., P.R.L. and I.G.-M.; software, J.V.-A.; validation, G.P.-N., J.V.-A., P.R.L. and I.G.-M.; formal analysis, J.V.-A., G.P.-N. and P.R.L.; investigation, J.V.-A., J.B. and G.P.-N.; resources, J.V.-A., J.B. and G.P.-N.; data curation, J.V.-A., J.B. and G.P.-N.; writing—original draft preparation, J.V.-A., J.B. and G.P.-N.; writing—review and editing, G.P.-N., P.R.L. and I.G.-M.; visualization, J.V.-A. and J.B.; supervision, G.P.-N. and I.G.-M.; project administration, G.P.-N., P.R.L. and I.G.-M.; funding acquisition, G.P.-N. All authors have read and agreed to the published version of the manuscript.

**Funding:** This research received no external funding.

**Institutional Review Board Statement:** The study was conducted according to the guidelines of the Declaration of Helsinki, and approved by the Institutional Review Board of UNIVERSIDAD TECNOLÓGICA INDOAMÉRICA (protocol code UTI-IIDI-017-2021, approval date 6 January 2021).

**Informed Consent Statement:** Informed consent was obtained from all subjects involved in the study.

**Data Availability Statement:** No new data were created or analyzed in this study. Data sharing is not applicable to this article.

**Acknowledgments:** The authors wish to thank the participants and the Universidad Tecnológica de Indoamérica for the support provided in this research. The authors also want to thank Doris Pérez, the neuropsychologist who assisted us with the intervention and development of the experiment.

**Conflicts of Interest:** The authors declare no conflict of interest.

## References

1. Waller, M.; Stotler, C. Telemedicine: A Primer. *Curr. Allergy Asthma Rep.* **2018**, *18*, 1–9. [[CrossRef](#)]
2. Kruse, C.S.; Krowski, N.; Rodriguez, B.; Tran, L.; Vela, J.; Brooks, M. Telehealth and patient satisfaction: A systematic review and narrative analysis. *BMJ Open* **2017**, *7*. [[CrossRef](#)]
3. Taylor, L.; Capling, H.; Portnoy, J.M. Administering a Telemedicine Program. *Curr. Allergy Asthma Rep.* **2018**, *18*. [[CrossRef](#)]
4. Alhalaili, B.; Popescu, I.N.; Kamoun, O.; Alzubi, F. Nanobiosensors for the Detection of Novel Coronavirus 2019-nCoV and Other Pandemic/Epidemic Respiratory Viruses: A Review. *Sensors (Basel)* **2019**, *20*, 6591. [[CrossRef](#)] [[PubMed](#)]
5. Kruse, C.S.; Lee, K.; Watson, J.B.; Lobo, L.G.; Stoppelmoor, A.G.; Oyibo, S.E. Measures of effectiveness, efficiency, and quality of telemedicine in the management of alcohol abuse, addiction, and rehabilitation: Systematic review. *J. Med. Internet Res.* **2020**, *22*. [[CrossRef](#)] [[PubMed](#)]
6. Mantovani, E.; Zucchella, C.; Bottiroli, S.; Federico, A.; Giugno, R.; Sandrini, G.; Chiamulera, C.; Tamburin, S. Telemedicine and Virtual Reality for Cognitive Rehabilitation: A Roadmap for the COVID-19 Pandemic. *Front. Neurol.* **2020**, *11*. [[CrossRef](#)]
7. Scott Kruse, C.; Karem, P.; Shifflett, K.; Vegi, L.; Ravi, K.; Brooks, M. Evaluating barriers to adopting telemedicine worldwide: A systematic review. *J. Telemed. Telecare* **2018**, *24*, 4–12. [[CrossRef](#)] [[PubMed](#)]
8. AlDossary, S.; Martin-Khan, M.G.; Bradford, N.K.; Smith, A.C. A systematic review of the methodologies used to evaluate telemedicine service initiatives in hospital facilities. *Int. J. Med. Inform.* **2017**, *97*, 171–194. [[CrossRef](#)] [[PubMed](#)]
9. Lawson, D.W.; Stolwyk, R.J.; Ponsford, J.L.; McKenzie, D.P.; Downing, M.G.; Wong, D. Telehealth Delivery of Memory Rehabilitation Following Stroke. *J. Int. Neuropsychol. Soc.* **2020**. [[CrossRef](#)] [[PubMed](#)]
10. Jain, T.; Mehrotra, A. Comparison of Direct-to-Consumer Telemedicine Visits with Primary Care Visits. *JAMA Netw. Open* **2020**, *3*, e2028392. [[CrossRef](#)] [[PubMed](#)]
11. Hooshmand, M.; Foronda, C. Comparison of telemedicine to traditional face-to-face care for children with special needs: A quasiexperimental study. *Telemed. e-Health* **2018**, *24*, 433–441. [[CrossRef](#)]

12. Lee, J.Y.; Lee, S.W.H. Telemedicine Cost-Effectiveness for Diabetes Management: A Systematic Review. *Diabetes Technol. Ther.* **2018**, *20*, 492–500. [[CrossRef](#)] [[PubMed](#)]
13. Di Tella, S.; Pagliari, C.; Blasi, V.; Mendozzi, L.; Rovaris, M.; Baglio, F. Integrated telerehabilitation approach in multiple sclerosis: A systematic review and meta-analysis. *J. Telemed. Telecare* **2020**, *26*, 385–399. [[CrossRef](#)] [[PubMed](#)]
14. Jansson, M.M.; Rantala, A.; Miettunen, J.; Puhto, A.P.; Pikkarainen, M. The effects and safety of telerehabilitation in patients with lower-limb joint replacement: A systematic review and narrative synthesis. *J. Telemed. Telecare* **2020**. [[CrossRef](#)] [[PubMed](#)]
15. Sarfo, F.S.; Ulasavets, U.; Opare-Sem, O.K.; Ovbiagele, B. Tele-Rehabilitation after Stroke: An Updated Systematic Review of the Literature. *J. Stroke Cerebrovasc. Dis.* **2018**, *27*, 2306–2318. [[CrossRef](#)]
16. Leochico, C.F.D. Adoption of telerehabilitation in a developing country before and during the COVID-19 pandemic. *Ann. Phys. Rehabil. Med.* **2020**. [[CrossRef](#)]
17. Withiel, T.D.; Wong, D.; Ponsford, J.L.; Cadilhac, D.A.; Stolwyk, R.J. Feasibility and effectiveness of computerised cognitive training for memory dysfunction following stroke: A series of single case studies. *Neuropsychol. Rehabil.* **2020**, *30*, 829–852. [[CrossRef](#)]
18. Eley, J.W.B.; Van Ast, V.A.; Kindt, M. Human memory reconsolidation: A guiding framework and critical review of the evidence. *Psychol. Bull.* **2018**, *144*, 797–848. [[CrossRef](#)] [[PubMed](#)]
19. Landauer, T.K.; Bjork, R.A. Optimal rehearsal patterns and name learning. In *Practical Aspects of Memory*; Gruneberg, M.M., Morris, P.E., Sykes, R.N., Eds.; Academic Press: London, UK, 1978; pp. 625–632.
20. Small, J.A. A new frontier in spaced retrieval memory training for persons with Alzheimer’s disease. *Neuropsychol. Rehabil.* **2012**, *22*, 329–361. [[CrossRef](#)] [[PubMed](#)]
21. Haslam, C.; Hodder, K.I.; Yates, P.J. Errorless learning and spaced retrieval: How do these methods fare in healthy and clinical populations? *J. Clin. Exp. Neuropsychol.* **2011**, *33*, 432–447. [[CrossRef](#)]
22. Cherry, K.E.; Walvoord, A.A.G.; Hawley, K.S. Spaced retrieval enhances memory for a name-face-occupation association in older adults with probable Alzheimer’s disease. *J. Genet. Psychol.* **2010**, *171*, 168–181. [[CrossRef](#)]
23. Germano, C.; Kinsella, G.J.; Storey, E.; Ong, B.; Ames, D. The episodic buffer and learning in early Alzheimer’s disease. *J. Clin. Exp. Neuropsychol.* **2008**, *30*, 627–638. [[CrossRef](#)]
24. Ozgis, S.; Rendell, P.G.; Henry, J.D. Spaced retrieval significantly improves prospective memory performance of cognitively impaired older adults. *Gerontology* **2009**, *55*, 229–232. [[CrossRef](#)] [[PubMed](#)]
25. Han, J.W.; Son, K.L.; Byun, H.J.; Ko, J.W.; Kim, K.; Hong, J.W.; Kim, T.H.; Kim, K.W. Efficacy of the Ubiquitous Spaced Retrieval-based Memory Advancement and Rehabilitation Training (USMART) program among patients with mild cognitive impairment: A randomized controlled crossover trial. *Alzheimer’s Res. Ther.* **2017**, *9*. [[CrossRef](#)]
26. Avci, G.; Woods, S.P.; Verduzco, M.; Sheppard, D.P.; Sumowski, J.F.; Chiaravalloti, N.D.; DeLuca, J. Effect of Retrieval Practice on Short-Term and Long-Term Retention in HIV+ Individuals. *J. Int. Neuropsychol. Soc.* **2017**, *23*, 214–222. [[CrossRef](#)] [[PubMed](#)]
27. Evans, C.R.; Medina, M.G.; Dwyer, A.M. Telemedicine and telerobotics: From science fiction to reality. *Updates Surg.* **2018**, *70*, 357–362. [[CrossRef](#)] [[PubMed](#)]
28. Makhni, M.C.; Riew, G.J.; Sumathipala, M.G. Telemedicine in Orthopaedic Surgery: Challenges and Opportunities. *J. Bone Joint Surg. Am.* **2020**, *102*, 1109–1115. [[CrossRef](#)]
29. Yaghobian, S.; Ohannessian, R.; Mathieu-Fritz, A.; Moulin, T. National survey of telemedicine education and training in medical schools in France. *J. Telemed. Telecare* **2020**, *26*, 303–308. [[CrossRef](#)]
30. Sapci, A.H.; Sapci, H.A. Digital continuous healthcare and disruptive medical technologies: M-Health and telemedicine skills training for data-driven healthcare. *J. Telemed. Telecare* **2019**, *25*, 623–635. [[CrossRef](#)]
31. Walker, C.; Echternacht, H.; Brophy, P.D. Model for medical student introductory telemedicine education. *Telemed. e-Health* **2019**, *25*, 717–723. [[CrossRef](#)]
32. Camden, C.; Pratte, G.; Fallon, F.; Couture, M.; Barbari, J.; Tousignant, M. Diversity of practices in telerehabilitation for children with disabilities and effective intervention characteristics: Results from a systematic review. *Disabil. Rehabil.* **2020**, *42*, 3424–3436. [[CrossRef](#)]
33. Provenzi, L.; Borgatti, R. Potentials of Telerehabilitation for Families of Children with Special Health Care Needs during the Coronavirus Disease 2019 Emergency. *JAMA Pediatrics* **2020**. [[CrossRef](#)]
34. Ownsworth, T.; Arnautovska, U.; Beadle, E.; Shum, D.H.K.; Moyle, W. Efficacy of Telerehabilitation for Adults with Traumatic Brain Injury: A Systematic Review. *J. Head Trauma Rehabil.* **2018**, *33*, E33–E46. [[CrossRef](#)]
35. Tinelli, F.; Cioni, G.; Purpura, G. Development and implementation of a new telerehabilitation system for audiovisual stimulation training in hemianopia. *Front. Neurol.* **2017**, *8*. [[CrossRef](#)]
36. Julien, M.; D’Amours, J.; Leduc, M.P.; Côté, A.C.; Oziel Rodier, R.; Demers, L.; Desrosiers, J. Responsiveness of the Box and Block Test with Older Adults in Rehabilitation. *Phys. Occup. Ther. Geriatr.* **2017**, *35*, 109–118. [[CrossRef](#)]
37. Gassert, R.; Dietz, V. Rehabilitation robots for the treatment of sensorimotor deficits: A neurophysiological perspective. *J. Neuroeng. Rehabil.* **2018**, *15*. [[CrossRef](#)] [[PubMed](#)]
38. Wang, Q.; Markopoulos, P.; Yu, B.; Chen, W.; Timmermans, A. Interactive wearable systems for upper body rehabilitation: A systematic review. *J. Neuroeng. Rehabil.* **2017**, *14*. [[CrossRef](#)]

39. Gallagher, R.; Roach, K.; Sadler, L.; Glinatsis, H.; Belshaw, J.; Kirkness, A.; Zhang, L.; Gallagher, P.; Paull, G.; Gao, Y.; et al. Mobile technology use across age groups in patients eligible for cardiac rehabilitation: Survey study. *JMIR mHealth uHealth* **2017**, *5*. [[CrossRef](#)] [[PubMed](#)]
40. Hoermann, S.; Ferreira dos Santos, L.; Morkisch, N.; Jettkowski, K.; Sillis, M.; Devan, H.; Kanagasabai, P.S.; Schmidt, H.; Krüger, J.; Dohle, C.; et al. Computerised mirror therapy with Augmented Reflection Technology for early stroke rehabilitation: Clinical feasibility and integration as an adjunct therapy. *Disabil. Rehabil.* **2017**, *39*, 1503–1514. [[CrossRef](#)] [[PubMed](#)]
41. Capri, T.; Nucita, A.; Iannizzotto, G.; Stasolla, F.; Romano, A.; Semino, M.; Giannatiempo, S.; Canegallo, V.; Fabio, R.A. Telerehabilitation for Improving Adaptive Skills of Children and Young Adults with Multiple Disabilities: A Systematic Review. *Rev. J. Autism Dev. Disord.* **2020**. [[CrossRef](#)]
42. Langan, J.; Subryan, H.; Nwogu, I.; Cavuoto, L. Reported use of technology in stroke rehabilitation by physical and occupational therapists. *Disabil. Rehabil. Assist. Technol.* **2018**, *13*, 641–647. [[CrossRef](#)]
43. Maggio, M.G.; Russo, M.; Cuzzola, M.F.; Destro, M.; La Rosa, G.; Molonia, F.; Bramanti, P.; Lombardo, G.; De Luca, R.; Calabrò, R.S. Virtual reality in multiple sclerosis rehabilitation: A review on cognitive and motor outcomes. *J. Clin. Neurosci.* **2019**, *65*, 106–111. [[CrossRef](#)] [[PubMed](#)]
44. Rizzo, A.S.; Shilling, R. Clinical Virtual Reality tools to advance the prevention, assessment, and treatment of PTSD. *Eur. J. Psychotraumatol.* **2017**. [[CrossRef](#)]
45. Moreno, A.; Wall, K.J.; Thangavelu, K.; Craven, L.; Ward, E.; Dissanayaka, N.N. A systematic review of the use of virtual reality and its effects on cognition in individuals with neurocognitive disorders. *Alzheimer's Dement. Transl. Res. Clin. Interv.* **2019**, *5*, 834–850. [[CrossRef](#)]
46. Park, M.J.; Kim, D.J.; Lee, U.; Na, E.J.; Jeon, H.J. A literature overview of virtual reality (VR) in treatment of psychiatric disorders: Recent advances and limitations. *Front. Psychiatry* **2019**, *10*, 1–9. [[CrossRef](#)] [[PubMed](#)]
47. Tieri, G.; Morone, G.; Paolucci, S.; Iosa, M. Virtual reality in cognitive and motor rehabilitation: Facts, fiction and fallacies. *Expert Rev. Med. Devices* **2018**, *15*, 107–117. [[CrossRef](#)]
48. Lindner, P.; Miloff, A.; Fagnäs, S.; Andersen, J.; Sigeman, M.; Andersson, G.; Furmark, T.; Carlbring, P. Therapist-led and self-led one-session virtual reality exposure therapy for public speaking anxiety with consumer hardware and software: A randomized controlled trial. *J. Anxiety Disord.* **2019**, *61*, 45–54. [[CrossRef](#)]
49. Isernia, S.; Di Tella, S.; Pagliari, C.; Jonsdottir, J.; Castiglioni, C.; Gindri, P.; Salza, M.; Gramigna, C.; Palumbo, G.; Molteni, F.; et al. Effects of an Innovative Telerehabilitation Intervention for People With Parkinson's Disease on Quality of Life, Motor, and Non-motor Abilities. *Front. Neurol.* **2020**, *11*. [[CrossRef](#)] [[PubMed](#)]
50. Torrisi, M.; Maresca, G.; De Cola, M.C.; Cannavò, A.; Sciarrone, F.; Silvestri, G.; Bramanti, A.; De Luca, R.; Calabrò, R.S. Using telerehabilitation to improve cognitive function in post-stroke survivors: Is this the time for the continuity of care? *Int. J. Rehabil. Res.* **2019**, *42*, 344–351. [[CrossRef](#)]
51. Imperatori, C.; Dakanalis, A.; Farina, B.; Pallavicini, F.; Colmegna, F.; Mantovani, F.; Clerici, M. Global Storm of Stress-Related Psychopathological Symptoms: A Brief Overview on the Usefulness of Virtual Reality in Facing the Mental Health Impact of COVID-19. *Cyberpsychology Behav. Soc. Netw.* **2020**, *23*, 782–788. [[CrossRef](#)]
52. Matsangidou, M.; Otkhmezuri, B.; Ang, C.S.; Avraamides, M.; Riva, G.; Gaggioli, A.; Iosif, D.; Karekla, M. "Now i can see me" designing a multi-user virtual reality remote psychotherapy for body weight and shape concerns. *Hum.-Comput. Interact.* **2020**. [[CrossRef](#)]
53. Cottrell, M.A.; Galea, O.A.; O'Leary, S.P.; Hill, A.J.; Russell, T.G. Real-time telerehabilitation for the treatment of musculoskeletal conditions is effective and comparable to standard practice: A systematic review and meta-analysis. *Clin. Rehabil.* **2017**, *31*, 625–638. [[CrossRef](#)]
54. Gil-Gomez, J.A.; Gil-Gomez, H.; Lozano-Quilis, J.A.; Manzano-Hernandez, P.; Albiol-Perez, S.; Aula-Valero, C. SEQ: Suitability Evaluation Questionnaire for Virtual Rehabilitation systems. Application in a Virtual Rehabilitation system for Balance Rehabilitation. In Proceedings of the 2013 7th International Conference on Pervasive Computing Technologies for Healthcare and Workshops, Venice, Italy, 5–8 May 2013; IEEE: Venice, Italy, 2013; pp. 335–338. [[CrossRef](#)]
55. Sayma, M.; Tuijt, R.; Cooper, C.; Walters, K. Are We There Yet? Immersive Virtual Reality to Improve Cognitive Function in Dementia and Mild Cognitive Impairment. *Gerontologist* **2019**. [[CrossRef](#)] [[PubMed](#)]
56. Varela-Aldás, J.; Palacios-Navarro, G.; Amariglio, R.; García-Magariño, I. Head-mounted display-based application for cognitive training. *Sensors (Switzerland)* **2020**, *20*, 6552. [[CrossRef](#)] [[PubMed](#)]
57. Doniger, G.M.; Beeri, M.S.; Bahar-Fuchs, A.; Gottlieb, A.; Tkachov, A.; Kenan, H.; Livny, A.; Bahat, Y.; Sharon, H.; Ben-Gal, O.; et al. Virtual reality-based cognitive-motor training for middle-aged adults at high Alzheimer's disease risk: A randomized controlled trial. *Alzheimer's Dement. Transl. Res. Clin. Interv.* **2018**, *4*, 118–129. [[CrossRef](#)]
58. Manenti, R.; Gobbi, E.; Baglio, F.; Macis, A.; Ferrari, C.; Pagnoni, I.; Rossetto, F.; Di Tella, S.; Alemanno, F.; Cimino, V.; et al. Effectiveness of an Innovative Cognitive Treatment and Telerehabilitation on Subjects With Mild Cognitive Impairment: A Multicenter, Randomized, Active-Controlled Study. *Front. Aging Neurosci.* **2020**, *12*, 400. [[CrossRef](#)]
59. Lecouvey, G.; Morand, A.; Gonneaud, J.; Piolino, P.; Orriols, E.; Pélerin, A.; Da Silva, L.F.; de La Sayette, V.; Eustache, F.; Desgranges, B. An impairment of prospective memory in mild Alzheimer's disease: A ride in a virtual town. *Front. Psychol.* **2019**, *10*, 1–12. [[CrossRef](#)] [[PubMed](#)]

60. La Corte, V.; Sperduti, M.; Abichou, K.; Piolino, P. Episodic memory assessment and remediation in normal and pathological aging using virtual reality: A mini review. *Front. Psychol.* **2019**, *10*, 1–6. [[CrossRef](#)]
61. Meltzer, J.A.; Baird, A.J.; Steele, R.D.; Harvey, S.J.; Meltzer, J.A.; Baird, A.J.; Steele, R.D.; Stephanie, J. Computer-based treatment of poststroke language disorders: A non-inferiority study of telerehabilitation compared to in-person service delivery. *Aphasiology* **2018**, *32*, 290–311. [[CrossRef](#)]
62. Van Der Linden, S.D.; Sitskoorn, M.M.; Jan, G.; Karin, M.R. Feasibility of the evidence-based cognitive telerehabilitation program Remind for patients with primary brain tumors. *J. Neurooncol.* **2018**, *137*, 523–532. [[CrossRef](#)]
63. Small, J.A.; Cochrane, D. Spaced retrieval and episodic memory training in Alzheimer’s disease. *Clin. Interv. Aging* **2020**, *15*, 519–536. [[CrossRef](#)] [[PubMed](#)]
64. Hawley, K.S.; Cherry, K.E. Spaced-retrieval effects on name-face recognition in older adults with probable Alzheimer’s disease. *Behav. Modif.* **2004**, *28*, 276–296. [[CrossRef](#)]
65. Tuena, C.; Pedroli, E.; Trimarchi, P.D.; Gallucci, A.; Chiappini, M.; Goulene, K.; Gaggioli, A.; Riva, G.; Lattanzio, F.; Giunco, F.; et al. Usability issues of clinical and research applications of virtual reality in older people: A systematic review. *Front. Hum. Neurosci.* **2020**, *14*. [[CrossRef](#)] [[PubMed](#)]
66. Salawu, A.; Green, A.; Crooks, M.G.; Brixey, N.; Ross, D.H.; Sivan, M. A proposal for multidisciplinary tele-rehabilitation in the assessment and rehabilitation of COVID-19 survivors. *Int. J. Environ. Res. Public Health* **2020**, *17*, 4890. [[CrossRef](#)] [[PubMed](#)]

## **4. DISCUSIONES Y CONCLUSIONES**

### **4.1 DISCUSIÓN GLOBAL**

Esta investigación se suma a los recientes estudios que han demostrado la viabilidad de realizar un instrumento válido para la evaluación y rehabilitación de la memoria basado en RV. El aporte metodológico y tecnológico de nuestra investigación, incluye la combinación de características modernas para mejores prestaciones en los sistemas actuales de salud cognitiva. La validez de constructo de las tareas diseñadas se basa en el rendimiento de la memoria a través de la precisión de las respuestas en las diferentes evaluaciones realizadas. En resumen, la tarea diseñada en la aplicación *AppLab* en ambos modos de juego está altamente asociada (a través del coeficiente de correlación de Pearson) con el test FNAME (Hopper et al., 2005) en cuanto a los resultados obtenidos. Por su parte, la tarea implementada en la aplicación *AppTele* obtuvo mejores resultados (estadísticamente significativos) en el grupo experimental (grupo de tele rehabilitación) con respecto al grupo de control (pruebas tradicionales para evaluar la memoria). A continuación, se discuten todos los resultados obtenidos en el contexto de otros trabajos relacionados encontrados en la literatura.

#### **Características de las aplicaciones de RV desarrolladas**

Nuestro trabajo ofrece un marco metodológico para el desarrollo de aplicaciones de RVi y RV no inmersiva usando componentes accesibles y de bajo coste (objetivo a). Las principales características de nuestras aplicaciones son la flexibilidad, personalización, facilidad de desarrollo y la optimización de recursos computacionales. Estos son elementos importantes en la gestión de proyectos de investigación debido a las limitaciones de tiempo y recursos.

Revisando las características de las aplicaciones desarrolladas, en la aplicación *AppLab*, los elementos tridimensionales del EV son instanciados usando objetos básicos del motor de juegos (Unity 3D) y se usa además un algoritmo automático para la generación de laberintos (Jeong & Kim, 2016). En la aplicación *AppTele*, se utilizan *Assets* prefabricados con detalles visuales simples y suficientes para cumplir el propósito del EV (Rizzo et al., 2004b). Estos detalles permiten la instalación de las aplicaciones en dispositivos con

características computacionales reducidas, favoreciendo la ejecución de las pruebas experimentales y haciendo este tipo de tecnología más accesible a la población.

Una característica importante que se implementó en la *AppTele* es la característica multiusuario, que permite la interacción en tiempo real dentro de la escena y desde cualquier parte del mundo. Los participantes visualizan el estado del EV que se modifica constantemente desde cualquier estación, y permite el intercambio fluido de voz, para la conversación paciente-medico. En nuestros resultados se presentaron las tasas de recepción de datos, con máximo 48.9 Kb/s y un promedio de 28.8 Kb/s, y las tasas de transmisión de datos, con máximo 31.8 Kb/s y un promedio de 17.5 Kb/s, valores muy aceptables que avalan el rendimiento optimizado de la herramienta utilizada (Photon Cloud). Las aplicaciones de RV con características multiusuario no han sido exploradas en rehabilitación cognitiva, pero han arrojado resultados prometedores en la rehabilitación física como en la terapia neuromuscular (Baur et al., 2018).

El hardware del sistema también es importante en el diseño e implementación de la aplicación de RV. En nuestro caso, hemos pasado de un primer dispositivo inmersivo como las gafas Gear VR, con claras limitaciones de autonomía, a unas gafas Oculus Go, un dispositivo totalmente independiente de bajo coste. Estos nuevos dispositivos están reduciendo la barrera para diferentes aplicaciones de RV, creando importantes oportunidades de mejorar los resultados y reducir el tiempo de implementación (Coburn et al., 2017). También hemos utilizado sistemas de escritorio para algún desarrollo, como la aplicación de tele rehabilitación (Varela-Aldás et al., 2021), donde el usuario interactúa con el EV a través de los periféricos de entrada y salida como el teclado, el ratón, los altavoces y el micrófono. Estos dispositivos son muy comunes en el hogar y son accesibles desde precios muy económicos. Aunque existe la tendencia hacia las pantallas portátiles como teléfonos y tabletas (Wiederhold et al., 2018), los participantes de mayor edad prefieren las aplicaciones de escritorio. Además, se ha demostrado que el tamaño de la pantalla influye positivamente en la navegación (Bowman & McMahan, 2007), siendo una limitante de las pantallas móviles comúnmente usadas. En cambio, las aplicaciones de escritorio han tenido buena aceptación incluso en pacientes con lesión cerebral adquirida (Kuil et al., 2018). La ubicuidad de estos

dispositivos favorece la habituación previo al experimento, haciendo que el proceso preparación del estudio sea más rápido y simple (Smith, 2019).

Un aspecto interesante que se ha considerado sobre todo en el diseño de la aplicación *AppLab* tiene que ver con los conceptos de navegación activa y pasiva (Chrastil & Warren, 2012). En concreto, el recorrido por el interior del laberinto se realiza en 2 modalidades de juego. En la literatura, el modo controlado (por el usuario) es considerado como navegación activa mientras que el modo autónomo (navegación automática) como navegación pasiva. La navegación activa tiene un papel importante en la adquisición del conocimiento espacial como órdenes motoras que determinan la trayectoria de locomoción, información propioceptiva y vestibular para el auto movimiento y asignación de atención a las características del entorno. Según Chrastil & Warren (2012) y Montana et al. (2019), estos componentes son influenciados positivamente en la navegación activa.

La navegación activa ayuda en el rendimiento de la memoria espacial, debido a que la interacción con el entorno y la planificación de trayectorias favorece la retención de esta información. Por el contrario, parece que la memoria episódica se ve afectada negativamente porque el control de las acciones produce un efecto atencional equivalente a realizar dos tareas de forma simultánea (Bréchet et al., 2019; Plancher et al., 2013). Estos antecedentes son consistentes con nuestros resultados, debido que la evaluación realizada en la *AppLab* involucra recordar los elementos presentados en el camino. En el modo autónomo se obtuvo una precisión en las respuestas del 85% y en el modo controlado del 61%, respectivamente. Esta notoria diferencia del 24% para nuestro grupo de participantes, respaldaría la teoría de que la navegación activa no favorece la codificación de los elementos presentados en el proceso de aprendizaje. Sin embargo, Jebara et al. (2014) concluyeron en su investigación que la navegación activa puede mejorar la memoria episódica cuando no es demasiado exigente para los recursos cognitivos de los participantes. Esto podría indicar que navegar de forma activa en la *AppLab* requiere un elevado esfuerzo cognitivo, creando el efecto de doble tarea que dificulta el aprendizaje.

## **Sujetos de estudio y efectos fisiológicos**

Con relación a los sujetos de nuestros estudios, la aplicación *AppLab* fue validada con una muestra de 29 participantes sanos con distribución equilibrada de género. El rango de edad de los sujetos fue de 16 a 64 años, con edad media de 31 años y una desviación estándar de 10 años. Por otro lado, la aplicación de rehabilitación *AppTele* utilizó dos grupos de participantes adultos sanos, un grupo experimental de 20 participantes (media 32 años  $\pm$  11 años) y un grupo de control de 20 participantes (media 35 años  $\pm$  13 años). Ambos grupos con equidad en cuanto al género (sin diferencias significativas con respecto al sexo). Además, los estudios con pacientes sanos son tomados como referencia de un adecuado estado cognitivo y los resultados pueden servir como punto de partida en trabajos futuros con sujetos con algún tipo de deterioro cognitivo, por ejemplo (Corriveau Lecavalier et al., 2020).

Se han realizado estudios similares con adultos jóvenes y mayores, y ambos eran capaces de realizar la tarea sin diferencias notables, sin efecto de suelo ni de techo. Ouellet et al. (2018) utilizó estos dos mismos grupos de participantes sanos, sin evidencia de dificultades con respecto a la navegación, y sin encontrar problemas de equilibrio o malestar. En nuestro estudio inmersivo con la *AppLab*, tuvimos que ajustar la velocidad de movimiento hasta que los participantes no presenten cinetosis, por lo que debería considerarse este parámetro en actividades que incluyen navegación dentro del EV. Este ajuste no fue necesario en la aplicación no inmersiva de la *AppTele*, debido a que no existieron síntomas.

## **Valoración cognitiva**

Uno de los principales hallazgos de esta investigación, es la validación de un instrumento para la valoración cognitiva de la memoria (objetivo d). Para esto se utiliza una herramienta tradicional de diagnóstico (FNAME), que permite discriminar el estado cognitivo de los pacientes. La relación entre la memoria y el test FNAME ha sido demostrada en pacientes con DCL (Hampstead et al., 2008).

En nuestro estudio, la medida de consistencia de los métodos aplicados en la investigación (experimental vs. tradicional) se realiza a través del coeficiente de correlación de Pearson. El análisis estadístico realizado demuestra una asociación significativa, positiva y grande de acuerdo con (Cohen, 1988), entre los resultados en la precisión de las respuestas



de la tarea implementada en la aplicación *AppLab* y los resultados obtenidos en el test FNAME. Se evidencia una mayor asociación en el modo controlado por el usuario ( $r = 0,577$ ,  $p = 0,001$ ) frente al modo autónomo ( $r = 0,435$ ,  $p = 0,018$ ). Esto quiere decir que la tarea ejecutada bajo la modalidad controlada por el usuario presenta un grado de asociación mayor entre la tarea virtual y la prueba tradicional. Estos resultados avalan la propuesta como un instrumento apto para el cribado cognitivo. No obstante, abren la puerta también a nuevos diseños en los que se aumente ligeramente la dificultad de la tarea con propósitos de diagnóstico, con el fin de dilucidar si ese incremento nos sirve para realizar un mejor cribado y detectar posibles deterioros cognitivos.

En la bibliografía existen antecedentes que avalan nuestros resultados, González-Landero et al. (2019) hallaron una correlación positiva y significativa ( $r = 0,62$ ,  $p = 0,002$ ) entre la precisión de las respuestas al usar un armario inteligente y la aplicación del test FNAME. La propuesta fue igualmente validada con una muestra de 23 participantes adultos sanos. En el mismo estudio existe otra consistencia con nuestros resultados. Las puntuaciones obtenidas en el test FNAME está siempre por debajo de los resultados medidos en las pruebas experimentales. Esto podría deberse a que la atención sostenida que caracteriza estas propuestas basadas en RV, ayuda a rescatar información que de otro modo se perdería o no estaría disponible para los procesos de recuperación. Incluso se ha demostrado que la atención protege los elementos para que no se olviden y ayuda a codificar de forma selectiva los elementos en la memoria visual (Matsukura et al., 2007; Murray et al., 2011; Zhang & Luck, 2008).

Henry et al. (2012) realizaron un estudio similar teniendo en cuenta la precisión de la respuesta y los tiempos de reacción en una tarea simple de RVi para medir la inhibición cognitiva y motora en adultos. Los resultados iniciales confirmaron correlaciones significativas entre las medidas de la tarea de RVi con medidas de varias pruebas neuropsicológicas. Por otro lado, Armstrong et al. (2013) encontraron en su estudio una asociación significativa en el desempeño en una tarea de RV (destinada al personal del ejército en servicio activo) con las pruebas tradicionales de atención y funcionamiento ejecutivo. Por su parte Parsons & McMahan (2017) en su validación inicial de una tarea basada en RVi, encontraron unos resultados que se correlacionaron igualmente con las

puntuaciones de las pruebas de memoria neuropsicológica tradicionales. Otro análisis interesante y similar se encontró en el estudio de Parsons & Rizzo (2008), en el que demostraron que su herramienta basada en RV permitía medir el aprendizaje y la memoria, y era inconsistente con las medidas proporcionadas por las pruebas tradicionales que miden otros dominios neurocognitivos.

Los anteriores resultados apoyan la validez ecológica de la aplicación, respaldando la premisa de que la herramienta tiene potencial discriminador del estado cognitivo del participante.

### **Tele rehabilitación cognitiva**

Respecto a nuestra propuesta de tele rehabilitación, se ha contrastado la precisión de las respuestas de la actividad experimental respecto a la actividad convencional de rehabilitación presencial (objetivo e). Los resultados de precisión en la evaluación retardada (evaluación final) favorecen ampliamente al método experimental con una precisión del 98%, en comparación con el método tradicional (68.6%). Se evidencia un efecto de techo para la aplicación de tele rehabilitación en varios participantes que presentan un puntaje del 100 %. Esto indica que el rendimiento de la evaluación final en la tarea de recuperación espaciada alcanza una mejor precisión, a pesar de haber utilizado los mismos elementos de memorización con ambos grupos (Varela-Aldás et al., 2021).

Estos resultados no son tan contundentes en la evaluación inicial (inmediata), con una diferencia de 14% entre ambos métodos (a favor del método experimental). Aun así, es notoria la mejora de la precisión al usar el sistema de RV no inmersiva, con diferencias significativas entre ambos grupos ( $F(1, 38) = 12,95, p = 0,001$ ) (Varela-Aldás et al., 2021). No se encontraron trabajos similares que ayuden a discutir este fenómeno de forma específica, pero son varios los estudios que avalan la mejora significativa del desempeño en evaluaciones cognitivas con RV al compararse con evaluaciones tradicionales (Georgiev et al., 2021; Riva et al., 2019; Ventura et al., 2019). Las principales razones de la mejoría se deben a la riqueza multimedia, la motivación, simulaciones incorporadas y la retroalimentación visual.

Aun teniendo en cuenta que los resultados en la tarea de recuperación espaciada por parte del grupo experimental han sido significativamente mejores que aquellos del grupo de control, podemos concluir que, al menos, los sistemas son equivalentes en cuanto a las prestaciones que ofrecen para la realización de una evaluación cognitiva. Esta mejora en las puntuaciones en el grupo experimental puede deberse a un mayor enfoque en la actividad, codificando los elementos en un entorno que les parece más atractivo. La adopción de este tipo de sistemas promueve una serie de factores claramente positivos en la rehabilitación, como una mayor motivación, compromiso, así como la capacidad de transferir habilidades cognitivas al mundo real (Mantovani et al., 2020).

El sistema de tele rehabilitación así implementado en la aplicación *AppTele* permite una interacción efectiva entre el paciente y el médico especialista para el entrenamiento cognitivo. Existen trabajos similares que evalúan el desempeño de un tratamiento presencial respecto un tratamiento remoto. Meltzer et al. (2018) realizó un estudio con 44 adultos que padecían trastornos de comunicación después de un accidente cerebrovascular. Los resultados fueron equivalentes para los servicios médicos cuando estos se brindaron a través de tele rehabilitación o bien en persona. Por su parte, van der Linden et al. (2018) desarrolló un programa de tele rehabilitación cognitiva para pacientes con tumores cerebrales primarios basados en programas cognitivos presenciales previamente evaluados. Este estudio piloto sugiere que la rehabilitación cognitiva posoperatoria es factible con esta nueva herramienta.

De esta forma se ha establecido un marco de referencia que puede ser utilizado por el personal sanitario para promover la rehabilitación cognitiva de forma remota y segura (objetivo c). No solo se automatizan los procesos, lo cual permite tener información más precisa e inequívoca, sino que se proyecta a un futuro, donde la presencia física no sea necesaria. Las ventajas que aporta este sistema son la simplicidad de uso, alta usabilidad y sostenibilidad, entre otros. Esto promueve la mejora de los sistemas de salud, que incrementan su eficiencia y superan las limitaciones geográficas (áreas de difícil acceso o con servicios de salud limitados) y temporales (reducción de tiempos de espera y transporte). De la misma forma, permite a los pacientes con movilidad reducida acceder a los profesionales sanitarios desde la comodidad de sus hogares. Todos estos argumentos ratifican

el enfoque ecológico que tiene la RV al combinarse con el acceso remoto que provee internet en la actualidad.

### **Usabilidad de las aplicaciones de RV**

Una vez que las aplicaciones han sido utilizadas en los experimentos, es importante recibir retroalimentación de los usuarios, con el fin de analizar la facilidad de uso, así como el grado de aceptación por parte de los participantes de tales herramientas (objetivo g).

La herramienta *AppLab* se evaluó usando el test USEQ (Gil-Gómez et al., 2017). Este es un cuestionario reducido diseñado específicamente para evaluar la satisfacción del usuario en los sistemas de rehabilitación de RV. Se obtuvieron puntuaciones del 94.5% (en media) teniendo en cuenta los resultados de los 29 participantes. Por su parte, la aplicación *AppTele* fue evaluada usando el test SEQ (Gil-Gomez et al., 2013). Este es un cuestionario de 14 preguntas para la evaluación de idoneidad diseñado específicamente para sistemas de rehabilitación virtual, obteniéndose una puntuación media del 91.77%. En cuanto a las diferencias entre los dos test utilizados, el test USEQ está limitado a la evaluación de la satisfacción del usuario, mientras que el test SEQ abarca la evaluación de usabilidad, aceptación y seguridad. De esta manera, la evaluación de la aplicación *AppLab* estuvo enfocada exclusivamente en la satisfacción del paciente, debido a que la inmersión aún es una tecnología poco utilizada. Por el contrario, la evaluación de la aplicación *AppTele* se enfocó en más factores, debido a que cubre una necesidad real provocada por la pandemia del COVID-19, por lo que tiene potencial de aplicación directa en los centros médicos de rehabilitación cognitiva. En ambos casos, dichas calificaciones avalan la idoneidad de las aplicaciones para un uso extendido.

### **Fog computing**

Internet se ha convertido en un componente de vital importancia en el desarrollo de sistemas tecnológicos de salud, que buscan como uno de sus objetivos arquitecturas que optimicen los recursos disponibles. Los resultados obtenidos en el primer trabajo de investigación sobre un sistema basado en esta tecnología de computación en la niebla para el seguimiento de pacientes con trastornos neurodegenerativos, se alinean perfectamente con estos objetivos (Hu et al., 2017). Con este trabajo se demostró que una arquitectura basada

en la computación en la niebla puede lograr costes computacionales muy reducidos sin apenas interferir con las comunicaciones de los hospitales, asignando la recopilación de datos a diferentes servidores, almacenando localmente la mayor cantidad de información, y enviando únicamente los resultados de la actividad.

Este enfoque fue aprovechado en el desarrollo de las aplicaciones *AppLab* y *AppTele*, respectivamente (objetivo f). Por un lado, en la aplicación inmersiva *AppLab* todos los datos se almacenan en el dispositivo HMD portable, enviando al servidor únicamente los datos históricos del paciente. Por otro lado, en la aplicación no inmersiva *AppTele*, la información enviada entre las estaciones (cliente y medico) son únicamente los resultados, las ordenes de sincronización del EV y el audio de los usuarios para una mínima latencia (Haouari et al., 2018).

### **Limitaciones**

Este trabajo de investigación ha tenido algunas limitaciones. Una primera cuestión que debe abordarse en investigaciones futuras es la validación de las herramientas desarrolladas en esta tesis con grupos de participantes más numerosos y de mayor edad. De esta manera tendremos una mayor evidencia para dilucidar si las tareas desarrolladas pueden ser sensibles en la precisión de las respuestas o en los tiempos de ejecución, con el propósito de diagnosticar de forma temprana las EN (Cavedoni et al., 2020). Esto permitirá extraer conclusiones interesantes y con ello reforzar la validez ecológica de las herramientas basadas en RV para su aplicación a una población que está sufriendo algún tipo de EN, tales como EP, EA o esclerosis múltiple (ES). Este tipo de herramientas ya están demostrando su importancia en la detección de disfunciones cognitivas que los tradicionales test no han sido capaces de hacerlo (Ruet & Brochet, 2020). Las restricciones de la pandemia COVID-19 no han permitido la inclusión de tales sujetos en nuestros estudios, por lo que se hace necesaria la realización de estudios con intervenciones más o menos dilatadas en el tiempo con este tipo de sujetos, evaluando si dichas intervenciones aportan información a la hora de detectar una pérdida de memoria y/o ralentizar el deterioro cognitivo (Cabinio et al., 2020).

### **4.2 CONCLUSIONES FINALES**

En este apartado explicaremos las principales aportaciones (originales) de esta tesis.

En primer lugar, esta tesis ha contribuido en la creación y validación (a través de herramientas y test previamente validados y ampliamente utilizados) de herramientas basadas en RV para la evaluación cognitiva. Estas herramientas se han enfocado fundamentalmente en ofrecer un servicio de rehabilitación por medio de la utilización de tecnologías de bajo coste. Las aplicaciones se han desarrollado aprovechando tanto las ventajas de las tecnologías de RV no inmersivas como las inmersivas, respectivamente.

Por otro lado, se ha generado un marco para crear aplicaciones de asistencia remota (tele rehabilitación) que han demostrado ser igualmente válidas para rehabilitación cognitiva como lo son los métodos tradicionales (objetivo b). Este marco tiene suma importancia por la flexibilidad que presenta fundamentalmente en su uso en tiempos de pandemia, donde la movilidad de las personas y la oferta de servicios sanitarios presenciales de ha visto claramente reducida debido a la pandemia COVID-19.

Como aportación también de esta tesis, destacamos la utilización del enfoque de computación en la niebla en el desarrollo de nuestras aplicaciones, con el fin de hacerlas óptimas en cuanto al ancho de banda de red requerido.

#### **4.3 TRABAJOS FUTUROS**

En lo que respecta a los potenciales desafíos a considerar en relación con la RV como herramienta de tratamiento cognitivo, destacamos a continuación unas interesantes líneas de trabajo para futuras investigaciones.

En primer lugar, son pocos los estudios que analizan la navegación activa en un EV y el efecto en el rendimiento de la memoria. Ésta incluye la actividad física y la actividad psicológica del usuario, es decir el control motor y toma de decisiones. De esta manera tenemos el efecto de recreación virtual (“virtual enactment”), que se define como la influencia que proporciona la navegación activa u otro componente en la recuperación de la memoria, en comparación con la observación pasiva virtual del EV (Tuena et al., 2019). Se produce aquí una asociación o analogía entre el efecto de representación (Engelkamp et al., 1994) y la navegación virtual activa, ya que ambos impactan de forma selectiva en el procesado específico de objetos como el reconocimiento, pero no así con el procesado relacional (agrupación semántica de conceptos, por ejemplo). Algunos estudios han

demostrado que este efecto es capaz de mejorar el rendimiento de la memoria espacial (Brooks et al., 1999) y la memoria episódica (Jebara et al., 2014). Sin embargo, estudios más recientes no encontraron diferencias significativas en el aprendizaje espacial al comparar ambos métodos de navegación (Barhorst-Cates et al., 2020). En el caso de la ME, la mejora parece estar limitada a la participación activa con poca exigencia cognitiva (Jebara et al., 2014), ya que hay investigaciones que reportan incluso un peor rendimiento cognitivo al incluir navegación activa (Plancher et al., 2013). Otras tareas de memoria como agrupación semántica, recuerdo libre o interferencia proactiva, sin embargo, no se ven mejoradas (Sauzéon et al., 2016). Es evidente que faltan estudios para aclarar estas incertidumbres, por lo que trabajos futuros deben incorporar pruebas con múltiples niveles de actividad en la navegación y evaluar estos tipos de memoria para mostrar evidencias más claras acerca de dichos efectos de la recreación virtual.

Otra interrogante que se nos plantea para el futuro tiene relación en el tipo de entorno de RV a utilizar (inmersivo vs. no inmersivo). Es la influencia de la inmersión en las aplicaciones de RV para el entrenamiento de la memoria, la pregunta es si la precisión en la recuperación de la memoria es mejor en los sistemas inmersivos respecto a las aplicaciones de escritorio (no inmersivo). Algunos trabajos como el de Krokos et al. (2019) y Plechatá et al. (2019) han mostrado mejoras significativas cuando los ejercicios se han realizado en entornos inmersivos (con respecto a su realización en entornos no inmersivos). En el primer caso, se encontraron diferencias significativas en el rendimiento de una prueba de memoria (mediante el método de Loci) por parte del grupo experimental (gafas de RV) frente al grupo de control, que utilizó una aplicación de escritorio (entorno no inmersivo). La mejora fue de un 8.8% extra en la capacidad de recuperación. Por el contrario, en el segundo estudio, los resultados mostraron una mejora en el rendimiento de la memoria episódica en el grupo que realizó el ejercicio de memoria en la condición de aplicación de escritorio. Así pues, queda camino por recorrer con el fin de dilucidar si el grado de inmersión garantiza un mejor desempeño en las diferentes tareas de memoria.

Un término muy relacionado con la inmersión de los sistemas de RV e inherente a ellos es la presencia. Reggente et al. (2020) desarrollaron una aplicación de RV que implementaba el método de Loci a través de dos variantes con diferente nivel de presencia.

El grupo que utilizó la aplicación con mayor nivel de presencia recordó un 28% más de objetos con respecto a la otra variante de la aplicación, lo que podría implicar una relación positiva entre el grado de presencia y el rendimiento cognitivo en la prueba. Otros hallazgos plantean la cuestión de si este beneficio solo se produce en los casos que la manipulación de la inmersión afecta a elementos del entorno que son directamente relevantes en la evaluación posterior de la memoria (Smith, 2019). Consideramos interesante, pues, en indagar esta cuestión, máxime cuando no hay una metodología clara que permita evaluar los niveles de presencia en los diferentes sistemas de RV. De momento, se han diseñado cuestionarios para obtener dichos niveles (Lessiter et al., 2001; Slater, 1999; Usoh et al., 2000) , aunque también hay estudios que sin usar cuestionarios, evalúan las respuestas de personas basándose en la psicofísica (Slater, 2018; Slater et al., 2010).

Cada vez son más los estudios basados en RV que introducen simulaciones de ADL's en la rehabilitación de déficits cognitivos. Parece ser que su utilización en estos EV han mostrado mejoras importantes en el funcionamiento general cognitivo con respecto a los métodos tradicionales (Faria et al., 2016). Autores como Foloppe et al. (2015) encontraron un caso en el que el entrenamiento en una cocina virtual permitió a un sujeto con EA reaprender actividades relativas a la cocina y dicho aprendizaje se mantuvo estable con el tiempo. Por su parte, el estudio de Liao et al. (2020) encontró que las funciones cognitivas de un grupo de adultos con DCL mostraron una mayor eficiencia neuronal y mejoras en las IADL mediante entrenamiento virtual. Todos estos antecedentes nos invitan a pensar en la necesidad de un marco metodológico para el diseño de tareas de RV que involucren ADL para la rehabilitación de pacientes con diferentes niveles de deterioro cognitivo, máxime dadas las diferentes condiciones clínicas que podemos encontrar en la población objetivo. Esta idea ya se ha desarrollado en el caso de aplicaciones móviles para supervisión de supervivientes de cáncer (Navarro-Alamán et al., 2020).

Otro campo en el que sería interesante actuar es el de los estímulos (cues o cueing) que pueden incorporarse en las aplicaciones de RV. Dichos estímulos tienen influencia directa en la representación del entorno, y la forma en que el cerebro combina estas entradas para la formación del mapa cognitivo son todavía cuestiones sin resolver en la neurociencia cognitiva. Por ejemplo, hay algún estudio como el de Faria et al. (2016), que incluyen la



técnica de las “fading cues” (Riley & Heaton, 2000), consiste en reducir progresivamente los estímulos proporcionados (normalmente a partir de la tercera sección) en una tarea o actividad cognitiva con el fin de ir incrementando el nivel de dificultad. Son pocas las investigaciones que analizan estas cuestiones en EV y tampoco se han encontrado estudios que contrasten los estímulos entre dispositivos inmersivos y no inmersivos, constituyendo una oportunidad para trabajos futuros.

En línea con esta última idea de incorporaciones a las aplicaciones de RV, encontramos los elementos distractores. No hemos encontrado muchos estudios mostrando evidencias de su efecto en el rendimiento cognitivo al incluirlos en las tareas. Castelhana & Henderson (2005) concluyeron en su estudio que no hay diferencias significativas al memorizar visualmente de forma intencional o incidental. Es decir, el rendimiento cognitivo no se ve influenciado cuando el sujeto es informado sobre los objetos a memorizar frente a los elementos distractores que aparecen en la escena y sobre los cuales luego se le pregunta. Williams (2010) por su parte, aun asumiendo la teoría anterior, concluyó que el procesamiento diferencial de los elementos a memorizar y de los distractores añadidos (tanto relacionados como no relacionados), hace que las tareas de codificación puedan tener efecto en la memoria visual. Es por ello que consideramos interesante señalar esta línea de estudio de la influencia de los distractores, determinando las ventajas y desventajas de incluirlos en las herramientas de rehabilitación cognitiva.

## 5. BIBLIOGRAFÍA

- Alcañiz, M., Bigné, E., & Guixeres, J. (2019). Virtual reality in marketing: A framework, review, and research agenda. *Frontiers in Psychology*. <https://doi.org/10.3389/fpsyg.2019.01530>
- Alhalaili, B., Popescu, I. N., Kamoun, O., Alzubi, F., Alawadhia, S., & Vidu, R. (2020). Nanobiosensors for the detection of novel coronavirus 2019-ncov and other pandemic/epidemic respiratory viruses: A review. *Sensors (Switzerland)*, 20(22), 1–45. <https://doi.org/10.3390/s20226591>
- Alzheimer's Association. (2015). 2015 Alzheimer's disease facts and figures. *Alzheimer's and Dementia*, 11(3), 332–384. <https://doi.org/10.1016/j.jalz.2015.02.003>
- Alzheimer's Association. (2017). 2017 Alzheimer's disease facts and figures. *Alzheimer's & Dementia*, 13(4), 325–373. <https://doi.org/10.1016/j.jalz.2017.02.001>
- American Psychiatric Association. (2013). Diagnostic and Statistical Manual of Dsm-5. In Am Psychiatric Assoc.
- Armstrong, C. M., Reger, G. M., Edwards, J., Rizzo, A. A., Courtney, C. G., & Parsons, T. D. (2013). Validity of the Virtual Reality Stroop Task (VRST) in active duty military. *Journal of Clinical and Experimental Neuropsychology*, 35(2), 113–123. <https://doi.org/10.1080/13803395.2012.740002>
- Barhorst-Cates, E. M., Rand, K. M., & Creem-Regehr, S. H. (2020). Does active learning benefit spatial memory during navigation with restricted peripheral field? *Attention, Perception, & Psychophysics* 2020 82:6, 82(6), 3033–3047. <https://doi.org/10.3758/S13414-020-02038-7>
- Baur, K., Schättin, A., Bruin, E. D. de, Rienner, R., Duarte, J. E., & Wolf, P. (2018). Trends in robot-assisted and virtual reality-assisted neuromuscular therapy: a systematic review of health-related multiplayer games. *Journal of NeuroEngineering and Rehabilitation*, 15(1), 107. <https://doi.org/10.1186/S12984-018-0449-9>
- Bowman, D. A., & McMahan, R. P. (2007). Virtual reality: How much immersion is enough? *Computer*, 40(7), 36–43. <https://doi.org/10.1109/MC.2007.257>
- Brade, J., Lorenz, M., Busch, M., Hammer, N., Tscheligi, M., & Klimant, P. (2017). Being there again – Presence in real and virtual environments and its relation to usability and user experience using a mobile navigation task. *International Journal of Human-Computer Studies*, 101, 76–87. <https://doi.org/10.1016/J.IJHCS.2017.01.004>
- Bréchet, L., Mange, R., Herbelin, B., Theillaud, Q., Gauthier, B., Serino, A., & Blanke, O. (2019). First-person view of one's body in immersive virtual reality: Influence on episodic memory. *PLoS ONE*, 14. <https://doi.org/10.1371/journal.pone.0197763>
- Broeren, J., Claesson, L., Goude, D., Rydmark, M., & Sunnerhagen, K. S. (2008). Virtual rehabilitation in an activity centre for community-dwelling persons with stroke. The possibilities of 3-dimensional computer games. *Cerebrovascular Diseases (Basel, Switzerland)*, 26(3), 289–296. <https://doi.org/10.1159/000149576>
- Brooke, J. (1996). SUS: A “Quick and Dirty” Usability Scale. *Usability Evaluation In Industry*, 207–212. <https://doi.org/10.1201/9781498710411-35>
- Brooks, B., Attree, E., Rose, F., Clifford, B., & Leadbetter, A. (1999). The specificity of memory enhancement during interaction with a virtual environment. *Memory (Hove, England)*, 7(1), 65–78. <https://doi.org/10.1080/741943713>
- Cabinio, M., Rossetto, F., Isernia, S., Saibene, F. L., Cesare, M. Di, Borgnis, F., Pazzi, S., Migliazza, T., Alberoni, M., Blasi, V., & Baglio, F. (2020). The Use of a Virtual Reality Platform for the Assessment of the Memory Decline and the Hippocampal Neural Injury in Subjects with Mild Cognitive Impairment: The Validity of Smart Aging Serious Game (SASG). *Journal of Clinical Medicine* 2020, Vol. 9, Page 1355, 9(5), 1355. <https://doi.org/10.3390/JCM9051355>

- Castelhano, M., & Henderson, J. (2005). Incidental visual memory for objects in scenes. *Visual Cognition*, 12(6), 1017–1040. <https://doi.org/10.1080/13506280444000634>
- Cavedoni, S., Chirico, A., Pedroli, E., Cipresso, P., & Riva, G. (2020). Digital Biomarkers for the Early Detection of Mild Cognitive Impairment: Artificial Intelligence Meets Virtual Reality. *Frontiers in Human Neuroscience*, 0, 245. <https://doi.org/10.3389/FNHUM.2020.00245>
- Chrastil, E. R., & Warren, W. H. (2012). Active and passive contributions to spatial learning. *Psychonomic Bulletin & Review*, 19(1), 1–23. <https://doi.org/10.3758/S13423-011-0182-X>
- Coburn, J. Q., Freeman, I., & Salmon, J. L. (2017). A Review of the Capabilities of Current Low-Cost Virtual Reality Technology and Its Potential to Enhance the Design Process. *Journal of Computing and Information Science in Engineering*, 17(3). <https://doi.org/10.1115/1.4036921>
- Cohen, J. (1988). *Statistical power analysis for the behavioral sciences*. Lawrence Erlbaum Associates.
- Collotta, M., Pau, G., & Costa, D. G. (2018). A fuzzy-based approach for energy-efficient Wi-Fi communications in dense wireless multimedia sensor networks. *Computer Networks*, 134, 127–139. <https://doi.org/10.1016/J.COMNET.2018.01.041>
- Corriveau Lecavalier, N., Ouellet, É., Boller, B., & Belleville, S. (2020). Use of immersive virtual reality to assess episodic memory: A validation study in older adults. *Neuropsychological Rehabilitation*, 30(3), 462–480. <https://doi.org/10.1080/09602011.2018.1477684>
- Crosbie, J. H., Lennon, S., McNeill, M. D. J., & McDonough, S. M. (2006). Virtual Reality in the Rehabilitation of the Upper Limb after Stroke: The User's Perspective. *CyberPsychology & Behavior*, 9(2), 137–141. <https://doi.org/10.1089/cpb.2006.9.137>
- Crosbie, J., McDonough, S., Lennon, S., & McNeill, M. (2005). Development of a virtual reality system for the rehabilitation of the upper limb after stroke. In C. D. Nugent et al. (Ed.), *Personalised Health Management Systems* (Vol. 117, pp. 218–222). IOS Press.
- Doniger, G. M., Beeri, M. S., Bahar-Fuchs, A., Gottlieb, A., Tkachov, A., Kenan, H., Livny, A., Bahat, Y., Sharon, H., Ben-Gal, O., Cohen, M., Zeilig, G., & Plotnik, M. (2018). Virtual reality-based cognitive-motor training for middle-aged adults at high Alzheimer's disease risk: A randomized controlled trial. *Alzheimer's and Dementia: Translational Research and Clinical Interventions*, 4, 118–129. <https://doi.org/10.1016/j.trci.2018.02.005>
- Dunn, J., Yeo, E., Moghaddampour, P., Chau, B., & Humbert, S. (2017). Virtual and augmented reality in the treatment of phantom limb pain: A literature review. *NeuroRehabilitation*. <https://doi.org/10.3233/NRE-171447>
- Engelkamp, J., Zimmer, H. D., Mohr, G., & Sellen, O. (1994). Memory of self-performed tasks: Self-performing during recognition. *Memory & Cognition*, 22(1), 34–39. <https://doi.org/10.3758/BF03202759>
- Farahani, B., Firouzi, F., Chang, V., Badaroglu, M., Constant, N., & Mankodiya, K. (2018). Towards fog-driven IoT eHealth: Promises and challenges of IoT in medicine and healthcare. *Future Generation Computer Systems*, 78, 659–676. <https://doi.org/10.1016/j.future.2017.04.036>
- Faria, A. L., Andrade, A., Soares, L., & Bermúdez I Badia, S. (2016). Benefits of virtual reality based cognitive rehabilitation through simulated activities of daily living: a randomized controlled trial with stroke patients. *Journal of Neuroengineering and Rehabilitation*, 13(1), 1–12. <https://doi.org/10.1186/S12984-016-0204-Z>
- Farshid, M., Paschen, J., Eriksson, T., & Kietzmann, J. (2018). Go boldly!: Explore augmented reality (AR), virtual reality (VR), and mixed reality (MR) for business. *Business Horizons*. <https://doi.org/10.1016/j.bushor.2018.05.009>
- Fernandez Montenegro, J. M., & Argyriou, V. (2017). Cognitive evaluation for the diagnosis of Alzheimer's disease based on Turing Test and Virtual Environments. *Physiology & Behavior*, 173, 42–51. <https://doi.org/10.1016/j.physbeh.2017.01.034>
- Foloppe, D. A., Richard, P., Yamaguchi, T., Etcharry-Bouyx, F., & Allain, P. (2018). The potential of virtual

reality-based training to enhance the functional autonomy of Alzheimer's disease patients in cooking activities: A single case study. *Neuropsychological Rehabilitation*, 28(5), 709–733. <https://doi.org/10.1080/09602011.2015.1094394>

Folstein, M. F., Folstein, S. E., & McHugh, P. R. (1975). "Mini-mental state": a practical method for grading the cognitive state of patients for the clinician. *Journal of Psychiatric Research*, 12(3), 189–198. [https://doi.org/10.1016/0022-3956\(75\)90026-6](https://doi.org/10.1016/0022-3956(75)90026-6)

Furht, B. (2008). Desktop Virtual Reality. *Encyclopedia of Multimedia*, 150–151. [https://doi.org/10.1007/978-0-387-78414-4\\_294](https://doi.org/10.1007/978-0-387-78414-4_294)

García-Betances, R. I., Arredondo Waldmeyer, M. T., Fico, G., & Cabrera-Umpiérrez, M. F. (2015). A succinct overview of virtual reality technology use in Alzheimer's disease. *Frontiers in Aging Neuroscience*, 7(APR), 80. <https://doi.org/10.3389/fnagi.2015.00080>

García-Betances, R. I., Jiménez-Mixco, V., Arredondo, M. T., & Cabrera-Umpiérrez, M. F. (2015). Using virtual reality for cognitive training of the elderly. *American Journal of Alzheimer's Disease & Other Dementias*, 30(1), 49–54.

García-Magariño, I., Gonzalez Bedia, M., & Palacios-Navarro, G. (2018). FAMAP: A Framework for Developing m-Health Apps (pp. 850–859). [https://doi.org/10.1007/978-3-319-77703-0\\_83](https://doi.org/10.1007/978-3-319-77703-0_83)

Georgiev, D. D., Georgieva, I., Gong, Z., Nanjappan, V., & Georgiev, G. V. (2021). Virtual Reality for Neurorehabilitation and Cognitive Enhancement. *Brain Sciences* 2021, Vol. 11, Page 221, 11(2), 221. <https://doi.org/10.3390/BRAINSCI11020221>

Gerber, S. M., Jeitziner, M. M., Knobel, S. E. J., Mosimann, U. P., Müri, R. M., Jakob, S. M., & Nef, T. (2019). Perception and Performance on a Virtual Reality Cognitive Stimulation for Use in the Intensive Care Unit: A Non-randomized Trial in Critically Ill Patients. *Frontiers in Medicine*. <https://doi.org/10.3389/fmed.2019.00287>

Gil-Gomez, J. A., Gil-Gomez, H., Lozano-Quilis, J. A., Manzano-Hernandez, P., Albiol-Perez, S., & Aula-Valero, C. (2013). SEQ: Suitability Evaluation Questionnaire for Virtual Rehabilitation systems. Application in a Virtual Rehabilitation system for Balance Rehabilitation. *Proceedings of the 2013 7th International Conference on Pervasive Computing Technologies for Healthcare and Workshops, PervasiveHealth 2013*. <https://doi.org/10.4108/icst.pervasivehealth.2013.252216>

Gil-Gómez, J. A., Manzano-Hernández, P., Albiol-Pérez, S., Aula-Valero, C., Gil-Gómez, H., & Lozano-Quilis, J. A. (2017). USEQ: A short questionnaire for satisfaction evaluation of virtual rehabilitation systems. *Sensors (Switzerland)*, 17(7), 1–12. <https://doi.org/10.3390/s17071589>

González-Landero, F., García-Magariño, I., Amariglio, R., & Lacuesta, R. (2019). Smart cupboard for assessing memory in home environment. *Sensors (Switzerland)*, 19(11), 2552. <https://doi.org/10.3390/s19112552>

Hampstead, B. M., Sathian, K., Moore, A. B., Nalisnick, C., & Stringer, A. Y. (2008). Explicit memory training leads to improved memory for face--name pairs in patients with mild cognitive impairment: Results of a pilot investigation. *Journal of the International Neuropsychological Society*, 14(5), 883–889.

Haouari, F., Faraj, R., & AlJa'am, J. M. (2018). Fog Computing Potentials, Applications, and Challenges. 2018 International Conference on Computer and Applications (ICCA), 399–406. <https://doi.org/10.1109 / COMAPP.2018.8460182>

Heeter, C. (1992). Being There: The Subjective Experience of Presence. *Presence: Teleoperators and Virtual Environments*, 1(2), 262–271. <https://doi.org/10.1162/pres.1992.1.2.262>

Henderson, A., Korner-Bitensky, N., & Levin, M. (2007). Virtual reality in stroke rehabilitation: a systematic review of its effectiveness for upper limb motor recovery. *Topics in Stroke Rehabilitation*, 14(2), 52–61. <https://doi.org/10.1310/tsr1402-52>

Henry, M., Joyal, C. C., & Nolin, P. (2012). Development and initial assessment of a new paradigm for assessing cognitive and motor inhibition: The bimodal virtual-reality Stroop. *Journal of Neuroscience Methods*, 210(2), 125–131. <https://doi.org/10.1016/j.jneumeth.2012.07.025>

- Hillmann, C. (2019). Comparing the Gear VR, Oculus Go, and Oculus Quest. In *Unreal for Mobile and Standalone VR* (pp. 141–167). Apress. [https://doi.org/10.1007/978-1-4842-4360-2\\_5](https://doi.org/10.1007/978-1-4842-4360-2_5)
- Holden, M. K. (2005). Virtual Environments for Motor Rehabilitation: Review. *CyberPsychology & Behavior*, 8(3), 187–211. <https://doi.org/10.1089/cpb.2005.8.187>
- Hopper, T., Mahendra, N., Kim, E., Azuma, T., Bayles, K. A., Cleary, S. J., & Tomoeda, C. K. (2005). Evidence-based practice recommendations for working with individuals with dementia: spaced-retrieval training. *Journal of Medical Speech - Language Pathology*, 13(4), xxvii–xxvii. <https://go.gale.com/ps/i.do?p=HRC&sw=w&issn=10651438&v=2.1&it=r&id=GALE%7CA141652403&sid=googleScholar&linkaccess=fulltext>
- Hu, P., Dhelim, S., Ning, H., & Qiu, T. (2017). Survey on fog computing: architecture, key technologies, applications and open issues. *Journal of Network and Computer Applications*, 98, 27–42. <https://doi.org/10.1016/j.jnca.2017.09.002>
- Iliadou, P., Paliokas, I., Zygouris, S., Lazarou, E., Votis, K., Tzovaras, D., & Tsolaki, M. (2021). A Comparison of Traditional and Serious Game-Based Digital Markers of Cognition in Older Adults with Mild Cognitive Impairment and Healthy Controls. *Journal of Alzheimer's Disease*, 79(4), 1747. <https://doi.org/10.3233/JAD-201300>
- Imperatori, C., Dakanalis, A., Farina, B., Pallavicini, F., Colmegna, F., Mantovani, F., & Clerici, M. (2020). Global Storm of Stress-Related Psychopathological Symptoms: A Brief Overview on the Usefulness of Virtual Reality in Facing the Mental Health Impact of COVID-19. *Cyberpsychology, Behavior, and Social Networking*, 23(11), 782–788. <https://doi.org/10.1089/cyber.2020.0339>
- Isernia, S., Di Tella, S., Pagliari, C., Jonsdottir, J., Castiglioni, C., Gindri, P., Salza, M., Gramigna, C., Palumbo, G., Molteni, F., & Baglio, F. (2020). Effects of an Innovative Telerehabilitation Intervention for People With Parkinson's Disease on Quality of Life, Motor, and Non-motor Abilities. *Frontiers in Neurology*, 11. <https://doi.org/10.3389/fneur.2020.00846>
- Jain, T., & Mehrotra, A. (2020). Comparison of Direct-to-Consumer Telemedicine Visits With Primary Care Visits. *JAMA Network Open*, 3(12), e2028392. <https://doi.org/10.1001/jamanetworkopen.2020.28392>
- Jebara, N., Orriols, E., Zaoui, M., Berthoz, A., & Piolino, P. (2014). Effects of enactment in episodic memory: a pilot virtual reality study with young and elderly adults. *Frontiers in Aging Neuroscience*, 6(DEC). <https://doi.org/10.3389/FNAGI.2014.00338>
- Jeong, K., & Kim, J. (2016). Event-Centered Maze Generation Method for Mobile Virtual Reality Applications. *Symmetry* 2016, Vol. 8, Page 120, 8(11), 120. <https://doi.org/10.3390/SYM8110120>
- Julayanont, P., & Nasreddine, Z. S. (2017). Montreal Cognitive Assessment (MoCA): Concept and Clinical Review. *Cognitive Screening Instruments: A Practical Approach*, 139–195. [https://doi.org/10.1007/978-3-319-44775-9\\_7](https://doi.org/10.1007/978-3-319-44775-9_7)
- Kao, H. Y., Wei, C. W., Yu, M. C., Liang, T. Y., Wu, W. H., & Wu, Y. J. (2018). Integrating a mobile health applications for self-management to enhance Telecare system. *Telematics and Informatics*, 35(4), 815–825. <https://doi.org/10.1016/j.tele.2017.12.011>
- Karpicke, J. D., & Bauernschmidt, A. (2011). Spaced Retrieval: Absolute Spacing Enhances Learning Regardless of Relative Spacing. <https://doi.org/10.1037/a0023436>
- Kivipelto, M., Mangialasche, F., Snyder, H. M., Allegri, R., Andrieu, S., Arai, H., Baker, L., Belleville, S., Brodaty, H., Brucki, S. M., Calandri, I., Caramelli, P., Chen, C., Chertkow, H., Chew, E., Choi, S. H., Chowdhary, N., Crivelli, L., Torre, R. D. La, ... Carrillo, M. C. (2020). World-Wide FINGERS Network: A global approach to risk reduction and prevention of dementia. *Alzheimer's & Dementia*, 16(7), 1078–1094. <https://doi.org/10.1002/alz.12123>
- Koné, Z. (2019). Adaptation of Mini Mental State Examination within a Population of Healthy Subjects in Mali: The Mamse. *Archives in Neurology & Neuroscience*, 4(2). <https://doi.org/10.33552/ann.2019.04.000584>

- Krohn, S., Tromp, J., Quinque, E. M., Belger, J., Klotzsche, F., Rekers, S., Chojecki, P., Mooij, J. de, Akbal, M., McCall, C., Villringer, A., Gaebler, M., Finke, C., & Thöne-Otto, A. (2020). Multidimensional Evaluation of Virtual Reality Paradigms in Clinical Neuropsychology: Application of the VR-Check Framework. *Journal of Medical Internet Research*, 22(4). <https://doi.org/10.2196/16724>
- Krokos, E., Plaisant, C., & Varshney, A. (2019). Virtual memory palaces: immersion aids recall. *Virtual Reality*. <https://doi.org/10.1007/s10055-018-0346-3>
- Kuil, M. N. A. van der, Visser-Meily, J. M. A., Evers, A. W. M., & Ham, I. J. M. van der. (2018). A Usability Study of a Serious Game in Cognitive Rehabilitation: A Compensatory Navigation Training in Acquired Brain Injury Patients. *Frontiers in Psychology*, 0(JUN), 846. <https://doi.org/10.3389/FPSYG.2018.00846>
- Lange, B., Koenig, S., Chang, C. Y., McConnell, E., Suma, E., Bolas, M., & Rizzo, A. (2012). Designing informed game-based rehabilitation tasks leveraging advances in virtual reality. *Disability and Rehabilitation*, 34(22), 1863–1870. <https://doi.org/10.3109/09638288.2012.670029>
- Langhorne, P., Coupar, F., & Pollock, A. (2009). Motor recovery after stroke: a systematic review. *The Lancet Neurology*, 8(8), 741–754. [https://doi.org/10.1016/S1474-4422\(09\)70150-4](https://doi.org/10.1016/S1474-4422(09)70150-4)
- Laver, K. E., Lange, B., George, S., Deutsch, J. E., Saposnik, G., & Crotty, M. (2017). Virtual reality for stroke rehabilitation. *Cochrane Database of Systematic Reviews*, 2017(11). <https://doi.org/10.1002/14651858.CD008349.pub4>
- Lawson, D. W., Stolwyk, R. J., Ponsford, J. L., McKenzie, D. P., Downing, M. G., & Wong, D. (2020). Telehealth Delivery of Memory Rehabilitation Following Stroke. *Journal of the International Neuropsychological Society*. <https://doi.org/10.1017/S1355617719000651>
- Lessiter, J., Freeman, J., Keogh, E., & Davidoff, J. (2001). A Cross-Media Presence Questionnaire: The ITC-Sense of Presence Inventory. *Presence: Teleoperators and Virtual Environments*, 10(3), 282–297. <https://doi.org/10.1162/105474601300343612>
- Liao, Y.-Y., Tseng, H.-Y., Lin, Y.-J., Wang, C.-J., & Hsu, W.-C. (2020). Using virtual reality-based training to improve cognitive function, instrumental activities of daily living and neural efficiency in older adults with mild cognitive impairment. *European Journal of Physical and Rehabilitation Medicine*, 56(1), 47–57. <https://doi.org/10.23736/S1973-9087.19.05899-4>
- Lloret, J., Parra, L., Taha, M., & Tomás, J. (2017). An architecture and protocol for smart continuous eHealth monitoring using 5G. *Computer Networks*, 129, 340–351. <https://doi.org/10.1016/j.comnet.2017.05.018>
- Manenti, R., Gobbi, E., Baglio, F., Macis, A., Ferrari, C., Pagnoni, I., Rossetto, F., Di Tella, S., Alemanno, F., Cimino, V., Binetti, G., Iannaccone, S., Bramanti, P., Cappa, S. F., & Cotelli, M. (2020). Effectiveness of an Innovative Cognitive Treatment and Telerehabilitation on Subjects With Mild Cognitive Impairment: A Multicenter, Randomized, Active-Controlled Study. *Frontiers in Aging Neuroscience*, 12, 400. <https://doi.org/10.3389/fnagi.2020.585988>
- Mantovani, E., Zucchella, C., Bottiroli, S., Federico, A., Giugno, R., Sandrini, G., Chiamulera, C., & Tamburin, S. (2020). Telemedicine and Virtual Reality for Cognitive Rehabilitation: A Roadmap for the COVID-19 Pandemic. *Frontiers in Neurology*, 11. <https://doi.org/10.3389/fneur.2020.00926>
- Maples-Keller, J. L., Bunnell, B. E., Kim, S. J., & Rothbaum, B. O. (2017). The use of virtual reality technology in the treatment of anxiety and other psychiatric disorders. *Harvard Review of Psychiatry*, 25(3), 103–113. <https://doi.org/10.1097/HRP.000000000000138>
- Matsangidou, M., Otkhmezuri, B., Ang, C. S., Avraamides, M., Riva, G., Gaggioli, A., Iosif, D., & Karekla, M. (2020). “Now i can see me” designing a multi-user virtual reality remote psychotherapy for body weight and shape concerns. *Human-Computer Interaction*. <https://doi.org/10.1080/07370024.2020.1788945>
- Matsukura, M., Luck, S. J., & Vecera, S. P. (2007). Attention effects during visual short-term memory maintenance: protection or prioritization? *Perception & Psychophysics*, 69(8), 1422–1434. <https://doi.org/10.3758/bf03192957>

- McNeill, M., Pokluda, L., McDonough, S., & Crosbie, J. (2004). Immersive virtual reality for upper limb rehabilitation following stroke. *Conference Proceedings - IEEE International Conference on Systems, Man and Cybernetics*, 3, 2783–2789. <https://doi.org/10.1109/ICSMC.2004.1400754>
- Meltzer, J. A., Baird, A. J., Steele, R. D., & Harvey, S. J. (2018). Computer-based treatment of poststroke language disorders: a non-inferiority study of telerehabilitation compared to in-person service delivery. *Aphasiology*, 32(3), 290–311. <https://doi.org/10.1080/02687038.2017.1355440>
- Montana, J. I., Tuena, C., Serino, S., Cipresso, P., & Riva, G. (2019). Neurorehabilitation of Spatial Memory Using Virtual Environments: A Systematic Review. *Journal of Clinical Medicine* 2019, Vol. 8, Page 1516, 8(10), 1516. <https://doi.org/10.3390/JCM8101516>
- Murray, A. M., Nobre, A. C., & Stokes, M. G. (2011). Markers of preparatory attention predict visual short-term memory performance. *Neuropsychologia*, 49(6), 1458–1465.
- Nasreddine, Z. S., Phillips, N. A., Bédirian, V., Charbonneau, S., Whitehead, V., Collin, I., Cummings, J. L., & Chertkow, H. (2005). The Montreal Cognitive Assessment, MoCA: a brief screening tool for mild cognitive impairment. *Journal of the American Geriatrics Society*, 53(4), 695–699.
- Navarro-Alamán, J., Raquel, L., Garcia-Magariño, I., & Gallardo, J. (2020). A methodology for the design and development of gamified mobile apps for monitoring cancer survivors. *Journal of Biomedical Informatics*, 106. <https://doi.org/10.1016/J.JBI.2020.103439>
- Naveh-Benjamin, M., Guez, J., Kilb, A., & Reedy, S. (2004). The Associative Memory Deficit of Older Adults: Further Support Using Face-Name Associations. *Psychology and Aging*, 19(3), 541–546. <https://doi.org/10.1037/0882-7974.19.3.541>
- Nilsson, N. C., Serafin, S., Steinicke, F., & Nordahl, R. (2018). Natural walking in virtual reality: A review. *Computers in Entertainment*. <https://doi.org/10.1145/3180658>
- Ouellet, É., Boller, B., Corriveau-Lecavalier, N., Cloutier, S., & Belleville, S. (2018). The Virtual Shop: A new immersive virtual reality environment and scenario for the assessment of everyday memory. *Journal of Neuroscience Methods*. <https://doi.org/10.1016/j.jneumeth.2018.03.010>
- Paolucci, S., Vita, A. Di, & Massicci, R. (2012). Impact of participation on rehabilitation results: a multivariate study. *European Journal of Physical and Rehabilitation Medicine*, 48(3), 455–466.
- Parsons, T. D., & Courtney, C. G. (2011). Neurocognitive and Psychophysiological Interfaces for Adaptive Virtual Environments (pp. 208–233). <https://doi.org/10.4018/978-1-60960-177-5.ch009>
- Parsons, T. D., Courtney, C. G., Arizmendi, B., & Dawson, M. (2011). Virtual reality stroop task for neurocognitive assessment. In *Medicine Meets Virtual Reality 18* (Vol. 163, pp. 433–439). IOS Press. <https://doi.org/10.3233/978-1-60750-706-2-433>
- Parsons, T. D., & McMahan, T. (2017). An initial validation of the Virtual Environment Grocery Store. *Journal of Neuroscience Methods*, 291, 13–19. <https://doi.org/10.1016/j.jneumeth.2017.07.027>
- Parsons, T. D., & Rizzo, A. A. (2008). Initial Validation of a Virtual Environment for Assessment of Memory Functioning: Virtual Reality Cognitive Performance Assessment Test. *CyberPsychology & Behavior*, 11(1), 17–25. <https://doi.org/10.1089/cpb.2007.9934>
- Peñasco Martín, B., de los Reyes Guzmán, A., Gil Agudo, A., Bernal Sahún, A., Pérez Aguilar, B., & de la Peña González, A. I. (2010). Aplicación de la realidad virtual en los aspectos motores de la neurorrehabilitación. *Revista de Neurología*, 51(08), 481. <https://doi.org/10.33588/rn.5108.2009665>
- Plancher, G., Julien, B., Orriols, E., & Piolino, P. (2013). The influence of action on episodic memory: a virtual reality study. *Quarterly Journal of Experimental Psychology*, 66(5), 895–909. <https://doi.org/10.1080/17470218.2012.722657>
- Plechata, A., Sahula, V., Fayette, D., & Fajnerová, I. (2019). Age-related differences with immersive and non-immersive virtual reality in memory assessment. *Frontiers in Psychology*, 10(JUN), 1330.

<https://doi.org/10.3389/fpsyg.2019.01330>

Rahmani, A. M., Gia, T. N., Negash, B., Anzanpour, A., Azimi, I., Jiang, M., & Liljeberg, P. (2018). Exploiting smart e-Health gateways at the edge of healthcare Internet-of-Things: A fog computing approach. *Future Generation Computer Systems*, 78, 641–658. <https://doi.org/10.1016/J.FUTURE.2017.02.014>

Reggente, N., Essoe, J. K. Y., Baek, H. Y., & Rissman, J. (2020). The Method of Loci in Virtual Reality: Explicit Binding of Objects to Spatial Contexts Enhances Subsequent Memory Recall. *Journal of Cognitive Enhancement*, 4(1), 12–30. <https://doi.org/10.1007/s41465-019-00141-8>

Rentz, D. M., Amariglio, R. E., Becker, J. A., Frey, M., Olson, L. E., Frishe, K., Carmasin, J., Maye, J. E., Johnson, K. A., & Sperling, R. A. (2011). Face-name associative memory performance is related to amyloid burden in normal elderly. *Neuropsychologia*, 49(9), 2776–2783. <https://doi.org/10.1016/j.neuropsychologia.2011.06.006>

Riley, G. A., & Heaton, S. (2000). Guidelines for the Selection of a Method of Fading Cues. *Neuropsychological Rehabilitation*, 10(2), 133–149. <https://doi.org/10.1080/096020100389219>

Riva, G., Wiederhold, B. K., & Mantovani, F. (2019). Neuroscience of Virtual Reality: From Virtual Exposure to Embodied Medicine. *Cyberpsychology, Behavior and Social Networking*, 22(1), 82. <https://doi.org/10.1089/CYBER.2017.29099.GRI>

Rizzo, A. A., Schultheis, M., Kerns, K. A., & Mateer, C. (2004a). Analysis of assets for virtual reality applications in neuropsychology. *Neuropsychological Rehabilitation*, 14(1–2), 207–239. <https://doi.org/10.1080/09602010343000183>

Rizzo, A. A., Schultheis, M., Kerns, K. A., & Mateer, C. (2004b). Analysis of assets for virtual reality applications in neuropsychology. *Neuropsychological Rehabilitation*, 14(1–2), 207–239. <https://doi.org/10.1080/09602010343000183>

Rose, F. D., Brooks, B. M., & Rizzo, A. A. (2005). Virtual Reality in Brain Damage Rehabilitation: Review. *CyberPsychology & Behavior*, 8(3), 241–262. <https://doi.org/10.1089/cpb.2005.8.241>

Rubiño, J., & Andrés, P. (2018). The Face-Name Associative Memory test as a tool for early diagnosis of alzheimer's disease. In *Frontiers in Psychology* (Vol. 9, Issue AUG). <https://doi.org/10.3389/fpsyg.2018.01464>

Ruet, A., & Brochet, B. (2020). Cognitive assessment in patients with multiple sclerosis: From neuropsychological batteries to ecological tools. *Annals of Physical and Rehabilitation Medicine*, 63(2), 154–158. <https://doi.org/10.1016/J.REHAB.2018.01.006>

Sarfo, F. S., Ulasavets, U., Opare-Sem, O. K., & Ovbiagele, B. (2018). Tele-Rehabilitation after Stroke: An Updated Systematic Review of the Literature. *Journal of Stroke and Cerebrovascular Diseases*, 27(9), 2306–2318. <https://doi.org/10.1016/j.jstrokecerebrovasdis.2018.05.013>

Sauzéron, H., N’Kaoua, B., Arvind Pala, P., Taillade, M., & Guitton, P. (2016). Age and active navigation effects on episodic memory: A virtual reality study. *British Journal of Psychology*, 107(1), 72–94. <https://doi.org/10.1111/bjop.12123>

Sayma, M., Tuijt, R., Cooper, C., Walters, K., & Heyn, P. C. (2020). Are We There Yet? Immersive Virtual Reality to Improve Cognitive Function in Dementia and Mild Cognitive Impairment. *Gerontologist*, 60(7), E502–E512. <https://doi.org/10.1093/geront/gnz132>

Schultheis, M. T., & Rizzo, A. A. (2001). The Application of Virtual Reality Technology in Rehabilitation. *Rehabilitation Psychology*, 46(3), 296–311.

Scott Kruse, C., Karem, P., Shifflett, K., Vegi, L., Ravi, K., & Brooks, M. (2018). Evaluating barriers to adopting telemedicine worldwide: A systematic review. *Journal of Telemedicine and Telecare*, 24(1), 4–12. <https://doi.org/10.1177/1357633X16674087>

Sendra, S., Parra, L., Lloret, J., & Tomás, J. (2018). Smart system for children's chronic illness monitoring. *Information Fusion*, 40, 76–86. <https://doi.org/10.1016/j.inffus.2017.06.002>



- Sherman, W. R., & Craig, A. B. (2003). Understanding Virtual Reality: Interface, Application, and Design. *Presence*, 12(4), 441–442. <https://doi.org/10.1162/105474603322391668>
- Slater, M. (1999). Measuring Presence: A Response to the Witmer and Singer Presence Questionnaire. *Presence: Teleoperators and Virtual Environments*, 8(5), 560–565. <https://doi.org/10.1162/105474699566477>
- Slater, M. (2018). Immersion and the illusion of presence in virtual reality. *British Journal of Psychology*, 109(3), 431–433. <https://doi.org/10.1111/bjop.12305>
- Slater, M., Spanlang, B., & Corominas, D. (2010). Simulating virtual environments within virtual environments as the basis for a psychophysics of presence. 1. <https://doi.org/10.1145/1833349.1778829>
- Smith, S. A. (2019). Virtual reality in episodic memory research: A review. *Psychonomic Bulletin and Review*, 26(4), 1213–1237. <https://doi.org/10.3758/s13423-019-01605-w>
- Sveistrup, H. (2004). Motor rehabilitation using virtual reality. *Journal of NeuroEngineering and Rehabilitation* 1, 1–10. <https://doi.org/https://doi.org/10.1186/1743-0003-1-10>
- Tarnanas, I., Schlee, W., Tsolaki, M., Müri, R., Mosimann, U., & Nef, T. (2013). Ecological validity of virtual reality daily living activities screening for early dementia: Longitudinal study. *JMIR Serious Games*, 1(1), e2778. <https://doi.org/10.2196/games.2778>
- Tieri, G., Morone, G., Paolucci, S., & Iosa, M. (2018). Virtual reality in cognitive and motor rehabilitation: facts, fiction and fallacies. *Expert Review of Medical Devices*, 15(2), 107–117. <https://doi.org/10.1080/17434440.2018.1425613>
- Tombaugh, T. N., & McIntyre, N. J. (1992). The Mini-Mental State Examination: A Comprehensive Review. *Journal of the American Geriatrics Society*, 40(9), 922–935. <https://doi.org/10.1111/J.1532-5415.1992.TB01992.X>
- Torrisi, M., Maresca, G., De Cola, M. C., Cannavò, A., Sciarrone, F., Silvestri, G., Bramanti, A., De Luca, R., & Calabrò, R. S. (2019). Using telerehabilitation to improve cognitive function in post-stroke survivors: is this the time for the continuity of care? *International Journal of Rehabilitation Research. Internationale Zeitschrift Fur Rehabilitationsforschung. Revue Internationale de Recherches de Readaptation*, 42(4), 344–351. <https://doi.org/10.1097/MRR.0000000000000369>
- Tuena, C., Pedroli, E., Trimarchi, P. D., Gallucci, A., Chiappini, M., Goulene, K., Gaggioli, A., Riva, G., Lattanzio, F., Giunco, F., & Stramba-Badiale, M. (2020). Usability issues of clinical and research applications of virtual reality in older people: A systematic review. *Frontiers in Human Neuroscience*, 14. <https://doi.org/10.3389/fnhum.2020.00093>
- Tuena, C., Serino, S., Dutriaux, L., Riva, G., & Piolino, P. (2019). Virtual Enactment Effect on Memory in Young and Aged Populations: A Systematic Review. *Journal of Clinical Medicine*, 8(5). <https://doi.org/10.3390/JCM8050620>
- Usoh, M., Catena, E., Arman, S., & Slater, M. (2000). Using Presence Questionnaires in Reality. *Presence: Teleoperators and Virtual Environments*, 9(5), 497–503. <https://doi.org/10.1162/105474600566989>
- Vallejo, V., Wyss, P., Rampa, L., Mitache, A. V., Müri, R. M., Mosimann, U. P., & Nef, T. (2017). Evaluation of a novel Serious Game based assessment tool for patients with Alzheimer’s disease. *PLoS ONE*, 12(5). <https://doi.org/10.1371/JOURNAL.PONE.0175999>
- van der Linden, S. D., Sitskoorn, M. M., Rutten, G. J. M., & Gehring, K. (2018). Feasibility of the evidence-based cognitive telerehabilitation program Remind for patients with primary brain tumors. *Journal of Neuro-Oncology*, 137(3), 523–532. <https://doi.org/10.1007/s11060-017-2738-8>
- van Helvoort, D., Stobbe, E., Benning, R., Otgaar, H., & van de Ven, V. (2020). Physical exploration of a virtual reality environment: Effects on spatiotemporal associative recognition of episodic memory. *Memory and Cognition*, 48(5), 691–703. <https://doi.org/10.3758/s13421-020-01024-6>
- Varela-Aldás, J., Buele, J., Lorente, P. R., García-Magariño, I., & Palacios-Navarro, G. (2021). A virtual reality-

based cognitive telerehabilitation system for use in the covid-19 pandemic. *Sustainability (Switzerland)*, 13(4), 1–24. <https://doi.org/10.3390/su13042183>

Ventura, S., Brivio, E., Riva, G., & Baños, R. M. (2019). Immersive Versus Non-immersive Experience: Exploring the Feasibility of Memory Assessment Through 360° Technology. *Frontiers in Psychology*. <https://doi.org/10.3389/fpsyg.2019.02509>

Voinescu, A., & David, D. (2019). The Effect of Learning in a Virtual Environment on Explicit and Implicit Memory by Applying a Process Dissociation Procedure. *International Journal of Human-Computer Interaction*, 35(1), 27–37. <https://doi.org/10.1080/10447318.2018.1424102>

Walker, C., Brouwer, B. J., & Culham, E. G. (2000). Use of visual feedback in retraining balance following acute stroke. *Physical Therapy*, 80(9), 886–895. <http://www.ncbi.nlm.nih.gov/pubmed/10960936>

Weibel, D., & Wissmath, B. (2011). Immersion in computer games: The role of spatial presence and flow. *International Journal of Computer Games Technology*, 2011. <https://doi.org/10.1155/2011/282345>

Wiederhold, B. K., Miller, I. T., & Wiederhold, M. D. (2018). Using Virtual Reality to Mobilize Health Care: Mobile Virtual Reality Technology for Attenuation of Anxiety and Pain. *IEEE Consumer Electronics Magazine*, 7(1), 106–109. <https://doi.org/10.1109/MCE.2017.2715365>

Williams, C. C. (2010). Incidental and intentional visual memory: What memories are and are not affected by encoding tasks? *Visual Cognition*, 18(9), 1348–1367. <https://doi.org/10.1080/13506285.2010.486280>

Wolfartsberger, J. (2019). Analyzing the potential of Virtual Reality for engineering design review. *Automation in Construction*. <https://doi.org/10.1016/j.autcon.2019.03.018>

Yavuzer, G., Senel, A., Atay, M. B., & Stam, H. J. (2008). “Playstation eyetoy games” improve upper extremity-related motor functioning in subacute stroke: a randomized controlled clinical trial. *European Journal of Physical and Rehabilitation Medicine*, 44(3), 237–244. <http://www.ncbi.nlm.nih.gov/pubmed/18469735>

Yung, R., & Khoo-Lattimore, C. (2019). New realities: a systematic literature review on virtual reality and augmented reality in tourism research. *Current Issues in Tourism*. <https://doi.org/10.1080/13683500.2017.1417359>

Zhang, W., & Luck, S. J. (2008). Discrete fixed-resolution representations in visual working memory. *Nature*, 453(7192), 233–235.

## 6. APÉNDICE

### 6.1 APÉNDICE 1: Factor de impacto y Área temática de las revistas

Revista	Año de publicación	Factor de Impacto	Área Temática	Cuartil
Peer-to-Peer Networking and Applications	2019	2.793	Telecommunications	Q2
Iberian Journal of Information Systems and Technologies	2019	0.14*	Computer Science (miscellaneous)	Q4
Sensors	2020	3.576	Engineering, Electrical & Electronic	Q2
			Instruments & Instrumentation	Q1
Sustainability **	2021	3.251	Environmental Studies	Q2
			Green & Sustainable Science & Technology	Q3

**Nota:** El factor de impacto y el cuartil corresponden al indicador Journal Citation Reports (JCR) según año de publicación.

\*El factor de impacto corresponde al indicador SCImago Journal Rank (SJR).

\*\* En esta revista el factor del impacto y cuartil corresponden al año 2020 debido a que los datos referidos al año de publicación (2021) no se han hecho públicos todavía.

## 6.2 APÉNDICE 2: Justificación de la contribución del doctorando

- I. García-Magariño, I., Varela-Aldas, J., Palacios-Navarro, G., & Lloret, J. (2019). Fog computing for assisting and tracking elder patients with neurodegenerative diseases. *Peer-to-Peer Networking and Applications*, 12(5), 1225-1235.**

El doctorando trabajó en la metodología y el desarrollo de la aplicación móvil de RV, en la validación y análisis de los datos de simulación, así como en la redacción del artículo.

- II. Varela-aldás, J., Palacios-navarro, G., García-magariño, I. (2019). Immersive virtual reality app for mild cognitive impairment. *Revista Ibérica de Sistemas y Tecnologías de la Información*, E19, 278–290.**

La contribución del doctorando en este segundo trabajo estuvo enfocada en la conceptualización de la investigación, el diseño y ejecución de la metodología, el desarrollo de la aplicación móvil de RVi, la recolección de datos experimentales y la aplicación del test de usabilidad. También colaboró en la realización del análisis estadístico y en la redacción del artículo, así como en las correcciones requeridas por los revisores.

- III. Varela-Aldás, J., Palacios-Navarro, G., Amariglio, R., & García-Magariño, I. (2020). Head-mounted display-based application for cognitive training. *Sensors*, 20(22), 6552.**

El doctorando participó en la conceptualización de la investigación, en el diseño y ejecución de la metodología, el tratamiento de los datos experimentales junto con el análisis estadístico. El diseño e implementación de la aplicación móvil de RVi corrió a cargo del doctorando en su totalidad. Igualmente, participó en la redacción del artículo y en las correcciones requeridas por los revisores de la revista.

- IV. Varela-Aldás, J., Buele, J., Ramos Lorente, P., García-Magariño, I., & Palacios-Navarro, G. (2021). A Virtual Reality-Based Cognitive TeleRehabilitation System for Use in the COVID-19 Pandemic. *Sustainability*, 13(4), 2183.**

Por último, la contribución del doctorando en este cuarto trabajo estuvo focalizada en el diseño y ejecución de la metodología, así como en el desarrollo de la aplicación de RV no inmersiva. Además, realizó el tratamiento de los datos y su análisis estadístico, junto con la redacción del artículo y en las correcciones solicitadas por los revisores de la revista.

### **6.3 APÉNDICE 3: Artículos en conferencias**

#### **V. Virtual Reality-Based Memory Assistant for the Elderly**

##### **Referencia:**

Chicaiza, F. A., Lema-Cerda, L., Álvarez, V. M., Andaluz, V. H., **Varela-Aldás, J.**, Palacios-Navarro, G., & García-Magariño, I. (2018). Virtual reality-based memory assistant for the elderly. *In International Conference on Augmented Reality, Virtual Reality and Computer Graphics* (pp. 269-284). Springer, Cham.



# Virtual Reality-Based Memory Assistant for the Elderly

Fernando A. Chicaiza<sup>1(✉)</sup>, Luis Lema-Cerda<sup>1(✉)</sup>,  
V. Marcelo Álvarez<sup>1(✉)</sup>, Víctor H. Andaluz<sup>1(✉)</sup>,  
José Varela-Aldás<sup>1,2(✉)</sup>, Guillermo Palacios-Navarro<sup>2(✉)</sup>,  
and Iván García-Magariño<sup>2(✉)</sup>

<sup>1</sup> Universidad de las Fuerzas Armadas ESPE, Sangolquí, Ecuador  
{fachicaiza, lalema, rmalvarez, vhandaluz,  
jlvarela}@espe.edu.ec

<sup>2</sup> University of Zaragoza, Zaragoza, Spain  
{palanava, ivangmg}@unizar.es

**Abstract.** Older adults experience several diseases related to the habits of their daily lives, many times resulting in cognitive problems when they reach ages that overcome eighty years. This work presents the development of an application aimed at older adults, integrating scenarios in virtual reality to facilitate the immersion of people with signs of memory loss. Through the application, various tasks related to daily activities, professions, face recognition and weekend games are proposed, all evaluated to show scores at the end of the activities. As a result, the work presents real experiments executed to validate the proposal, showing first and third person views within several built virtual environments.

**Keywords:** Elderly · Virtual reality · Memory assistant  
Third level immersion

## 1 Introduction

The human being goes through different stages during his development, initiating the process of aging at 65 years of age [1, 2]. An older adult integrates one of the most important groups within society, this consideration is determined given the tendency of the distribution of the population pyramid, mainly considering the new indexes identified towards life expectancy and the decrease in the fertility rate. According to the World Health Organization (WHO), the studies given in 2016 reflect that more than 22 countries exceeded on average 80 years of age, and in some cases exceeded 82 years. Furthermore, studies reveal that the growth of the adult population by 2050 will be 2000 million older adults, in contrast to the year 2000 where there were 605 million, estimating that soon the records of history will be surpassed with the greatest number of octogenarian individuals [3]. Likewise, by the year 2050, it is estimated that there will be a world population of approximately 395 million people in need of assistance, due to bad habits and exposure to toxic substances such as cigarettes,

alcohol and other narcotics which threaten the health of the population, having a direct impact on their mental performance [4].

Aging does not necessarily lead to health problems. According to medical studies, there are several ways to evaluate the consequences of the body's aging through the years, according to this, it can be identified some changes such as levels of consciousness, orientation in time and space; intellectual retardation, dementia; energy and motor function; attention horizon, sleep capacity; perceptions; emotions; high cognitive level, language management, and so on. In the same way, it is relevant to identify the changes given through sensory functions, in this sense, vision, hearing, balance and even pain management are evaluated. Besides, physiological changes produced by aging, i.e., cardiovascular functions, blood pressure, diabetes, hematology, immunology, tendency to suffer hypersensitivity, allergies, fatigue, and respiratory affection need to be taken into account [5].

The learning of new information, the ability to solve everyday problems, active listening, reading and writing ability, arithmetic, financial calculation, and so on, are developed given the conservation of memory and adequate cognitive conditions. Personal care is part of the aforementioned conservation, therefore, grooming, feeding, taking medication; that is, self-care can be affected when considering memory conditions. However, literature identifies ways to maintain mental lucidity in order to preserve personal interrelations and promote cognitive functions, often based on technology [6, 7].

Technological advances directly impact the development of human activities. Within the applications related to the conservation of health, the affections to memory have had a great research niche, generating some applications called Serious Games. Within this context, Table 1 identifies some of these applications [8].

**Table 1.** Support applications for the elderly

Nombre	Objeto
Gradior	Various exercises for cognitive functions
Rehacom	Training, maintenance and stimulation of cognitive functions
Smartbrain	Exercises of memory, language, calculation, orientation, attention, recognition
Tweri	Mobile application for distraction, ride in areas with security limit
NeuronUp	Neuropsychological rehabilitation
PSSCog Rehab	Rehabilitation system of cognitive therapy, memory improvement
C. Enhancement Therapy	Therapy based on individual exercises from the visual to spatial skills
Neuropsychonline	Cognitive multimodal rehabilitation, improvement of memory and abilities
Challenging Our Minds Cognitive	Rehabilitation parameterized in several stages according to the patient's requirement

(continued)

**Table 1.** (continued)

Nombre	Objeto
NeuroPersonal Trainer	Originally designed for patients with brain trauma and memory loss
CogniFit	Includes scientific questionnaires with cognitive abilities of patients
Lumosity	Training tools for patients with critical memory loss
MindMate	Fun and interactive games to improve the patient's cognitive skills
Elude	In a clinical context, it supports acute depression and dangerous conditions
RehaCom	Cognitive training solutions in different institutional, clinical and home environments

Under these conditions, this article focuses on identifying the support that information and communication technologies represent in the preventive process of patients with apparent memory loss. It is relevant to note that the applications identified have not yet included the benefits of virtual reality [9]. Within the virtual reality interfaces, there are applications which allow establishing activities around the management of the activities for the elderly, considering some criteria contributed by several authors [10, 11]. Additionally and under other perspectives, the following applications can be mentioned: Talking Tom 2, My Reef 3D, Let's create! Pottery, Augment, FlowerGarden, MindMate, and so on [12].

As described in previous paragraphs, this work proposes the development of an application based on virtual reality (VR) oriented to preventive and corrective processes of memory loss. The proposed application mainly considers four interactive modules in which both the virtual user-environment interaction and three level immersion are considered: (i) *Home Tasks*, considers virtual environments related to home in order to perform different daily activities, e.g., laundry, shopping, grocery shopping, and so forth; (ii) *Professional Tasks*, poses tasks related to work activities in a factory; (iii) *Relatives recognition*, evaluates the answers given by the user and compares them with a pre-configured database for the recognition of people, and (iv) *weekend games*, provides environments for the execution of entertainment activities.

This work is split into 6 Sections, including the Introduction. The proposal is presented in Sect. 2; while the description of the application is presented in Sect. 3. Section 4 describes the workflow of the proposed assistant, showing the experimental results in Sect. 5. Finally, Conclusions are presented in Sect. 6.

## 2 Formulation Problem

According to several studies, three conditions required to consider cognitive problems in an older adult are recognized: (i) progressive deterioration in at least two domains of cognitive function, including memory, (ii) interference in a relevant way with natural



behaviour in the person’s social and family field and, (iii) absence of an alternative explanation for this disorder, for example, depression. The recognition of a problem related to the progressive memory deterioration continues with the identification of therapies to try to reduce the short or long term conditions of the diseases. Within these considerations, factors such as costs, the place of rehabilitation and the professionals involved must be taken into account prior to selecting an appropriate treatment.

In this context, the development of applications which work as support in the cognitive rehabilitation of patients can act as an innovative and economically profitable tool, where three fundamental categories can be considered to attract the user to this type of applications: (1) modification of environments, (2) compensatory strategies and (3) cognitive function restoration techniques. The present work focuses on the first two categories, in order to provide an assistant to avoid future difficulties which can arise as a result of memory problems. Figure 1 shows the simplified proposal of the application to be implemented, involving recognition activities, simple answer questions and various activities, where the execution results are evaluated to show the level of coincidence between the information stored and the user’s response.

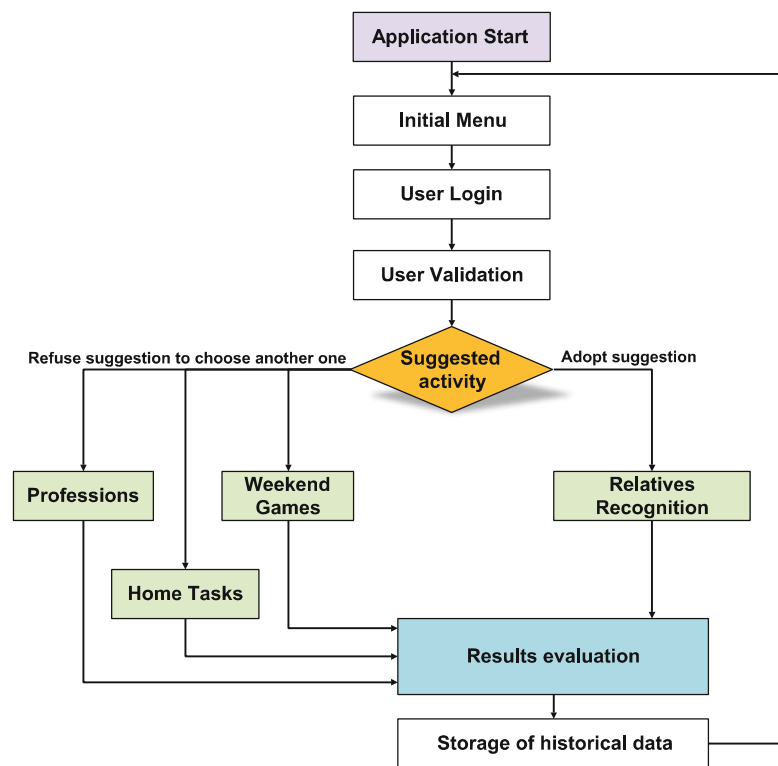


Fig. 1. Application proposal to strengthen memory of older adults

This work considers an application aimed at the use of virtual reality as a way to represent the daily environment of patients. Starting with the user’s login, the application challenges the user to remember daily details through a validation question. Overcoming the short question implies that the user can choose an activity to develop,

of which four different types of tasks are proposed. Through scenarios built in Unity 3D, everyday tasks such as making purchases, washing clothes, and so on are raised. In the same way, environments which recreate a factory for the execution of work tasks or the recognition of relatives are options which the application raises to maintain the user’s concentration. Additionally, several games are designed to distract the user, where the set of input devices allow controlling the application. Considering that the application consumes geo-referenced time information, the activities are suggested depending on the day in which the older adult enters the system. Consequently, the application integrates an evaluation of results to display the level of coincidence between the expected responses and the generated responses and, finally, the data is stored in a database to analyse the evolution of the user.

### 3 System Structure

The system structure developed consists of four groups including: game objects (Unity Scenes), modules to control each game object (Scripts), information Input Devices, and Output Devices. Figure 2 shows the general structure of the system, where it is included all the components and how they are linked.

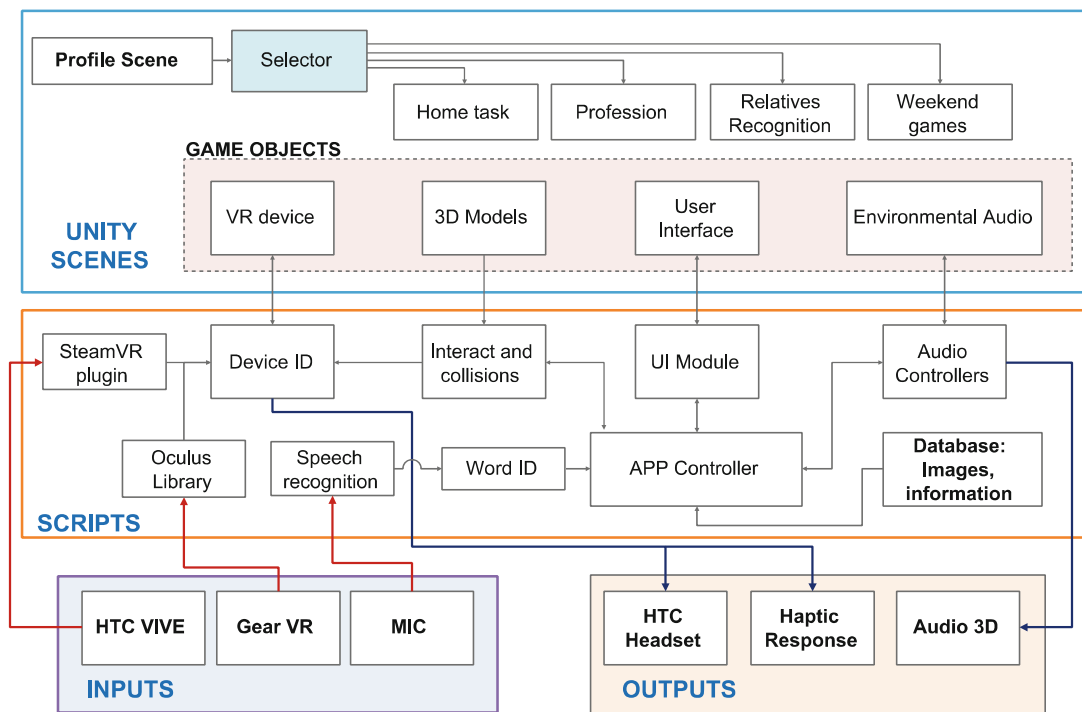


Fig. 2. System general structure

The *Unity scenes* contain the elements to build the virtual environments, depending on the selected scene. At this stage, characteristics such as gravity, haptic and audio responses, and other physical properties are set in order to recreate real interaction

based scenarios. In addition, menus are created for accessing the different environments, in this case: home tasks, profession activities, relatives recognition and relaxation games, as well as auxiliary windows with guide information to execute each task. Each 3D model, virtual reality devices, interfaces and audio source are generically defined as a game object, by means of which scripting modules can modify their behaviour. All the elements of this stage are connected to modules and plugins to specify the game objects within the scenarios.

The Scripts group is the block which allows communicating the Unity Scenes with the input and output devices, perform mathematical calculations, control each of the game objects and generate execution sequences. Depending on the input device, the Oculus library or the SteamVR plugin can be activated to manage the resources provided by the hardware (Gear VR or HTC VIVE). Regardless of the connected device, the Interact and Collision module allows the dynamic interaction between the hardware and the game object modules, reusing the code of the n devices. In turn, the audio input can be provided by the microphone integrated to the selected hardware, which is connected to the speech recognition module to detect the user's interaction with the application through voice commands, where the speech fragment is analyzed by the word identification module to recognize keywords. The information provided by the -interact and collisions- modules and Word ID are administered by the APP controller, defined as the main scripting module. In addition, the UI module is called upon in order to control the navigation throughout all the scenes of the application; while the audio module manages the sound effects through a game object and in turn, it sends 3D audio hardware as a final response to the user. Finally, a database containing user-specific information is considered, which is used dynamically by the APP controller.

**Remark 1:** The scripting modules can be integrated by one or several scripts.

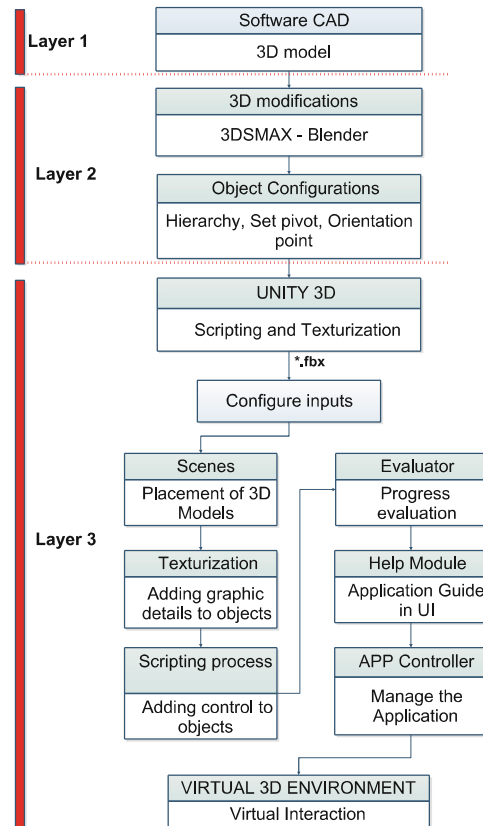
**Remark 2:** The application compatibility is developed for HTC VIVE and GearVR platforms in order to take advantage of each one. In the first case, the work area of  $4 \times 3$  meters is used in which the user can move; while in the second case, the ease of execution without the help of third parties is exposed. In this way, the application can be used in a care centre for the first case, and an individual use for the second one.

The scripting block consumes the raw data of the inputs, processes them and sends results to the output module. In this way, the *Input Block* contains the HTC VIVE & GEAR VR devices, which are objective platforms for the application. Meanwhile, the *Output Block* contains three modules which receive dynamic visual, haptic, and audible feedback from the interaction.

## 4 Virtual Environment Interface Development

For the creation of the application and the functionalities of each of the scenarios, it is required to follow a set of steps, defined in this work as stages (Fig. 3). The stages are split into four parts, in which the creation of models in computer-aided design software is considered; the import of the models to Unity and the construction and programming of each one of the scenes. In *(i) the First Layer*, it is considered that the objects required to build each of the scenes are created by CAD software packages. These objects can be

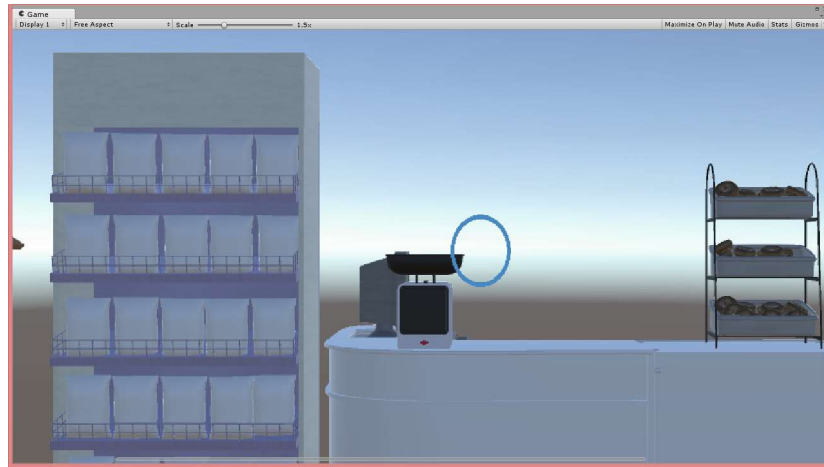
exported in a format compatible with Unity, but with the lack of necessary properties in the feature axis of scenes. To supply those properties, (ii) *the Second Layer* allows grouping objects by chains to form hierarchies, so that when executing movements of pieces of an object, all the pieces which have a mechanical relationship move in coordination with the displaced section. Additionally, this layer allows setting pivot points at the origin to each of the pieces that make up a model, individually or grouped. The result of this layer is an adaptable file format for 3D animation software (\*.fbx), which is a file fully compatible with Unity 3D.



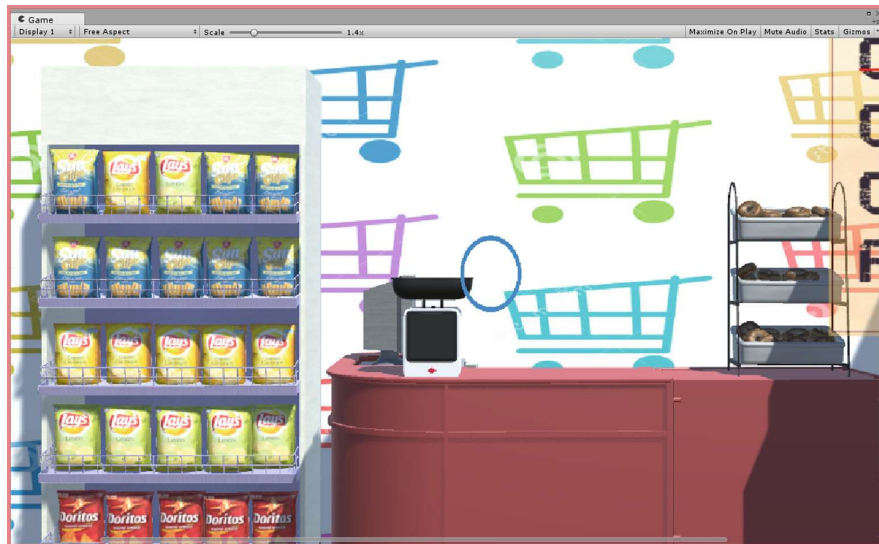
**Fig. 3.** Desarrollo de la interface de realidad virtual

*Layer 3* runs completely in Unity 3D, allowing the textures assignment and evaluate the execution of the task to calculate results. In the configure inputs block, generic algorithms are made to manipulate interacting objects regardless of the input hardware. Next, the scenes are constructed using the 3D models resulting from the second layer and a layout of all 3D environments is obtained to later perform the texturing task (Fig. 4).

The texturization block includes the use of photorealistic colours, materials and textures to provide detail to each of the objects in the scene, where third-party complements can be used to achieve similarity in the colours recreation. In addition to this, lightning is configured in each environment to provide realism, depending on whether it is indoor or outdoor (Fig. 5). Although the so far elements have a close similarity to a



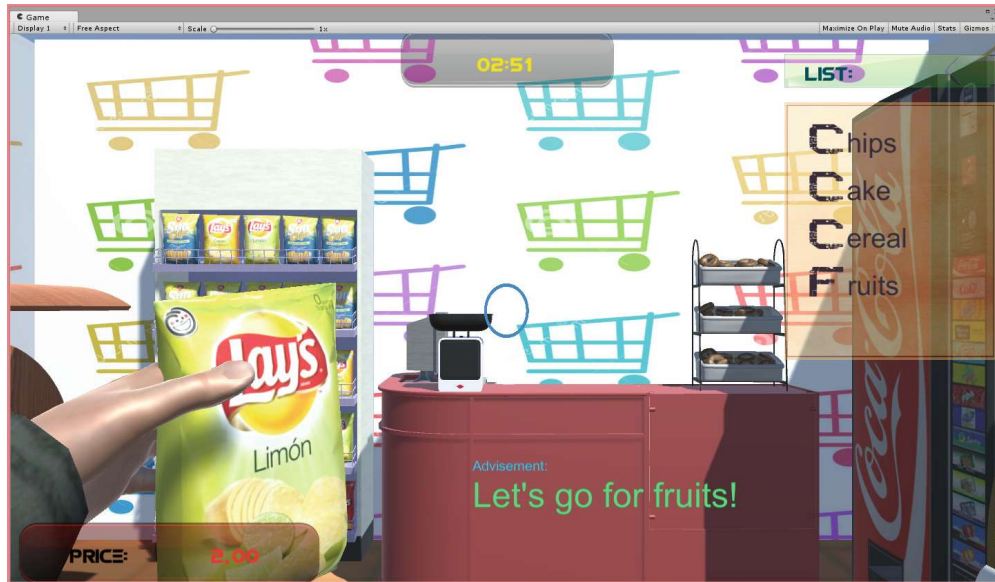
**Fig. 4.** Environment layout



**Fig. 5.** Application of texturing, colour and lightning to the stage

real environment and are distributed throughout the scene, they lack scripts which allow to include some type of control.

The scripting process allows to control the objects depending on the inputs generated by the user (audio, buttons of the input devices, etc.), to program the sequence in how the processes are executed, to perform mathematical calculations, to create animations, and so on (Fig. 6). The scripting process is directly related to the task evaluator, in charge of validating the subtasks executed, as well as calculating the total number of hits and the time spent by the activity to show results. Additionally, the Help module is activated when the inactivity time exceeds a predetermined value, using this factor to display help information if the user does not get hits or does not enter information into the system. Finally, all the modules are managed by the user through the APP controller,



**Fig. 6.** Use of scripting to control objects

allowing the sequence to converge in the interactive three-dimensional virtual environment and granting a level of third-degree immersion to the user.

## 5 Results

The results presented in this Section show the performance of the developed application. In order to reinforce self-identification, the first window identifies the user through his name and validates it with one of short questions pre-recorded at the beginning of the therapy. Short questions are parameters previously stored in a repository, while names are part of a dynamic memory that is fed back every time there is a new entry, so that the system can store profiles of users who previously used the program. The use of a short name and simple answer questions facilitates the work of the speech recognition module, where answers of less than 10 words are expected. Figure 7 (a) presents the welcome window to the memory trainer (in which new users can be included), continue with the session of the last user or search in the profile repository. The user selection continues with the user's validation (Fig. 7 (b)), where questions such as the name of a childhood pet, home address, telephone number, recognition of a family member, and so on, allow access to the exercises (Fig. 7 (c)).

**Remark 3:** The application includes a passive time counter which is activated when there is no response from the user or if the number of responses does not match the correct answers stored. In this case, a help method is displayed to guide the user to continue with the task (Fig. 6).

Depending on the day, the application suggests the execution of a specific task, where the activities that require greater concentration have preference during the week, while the tasks related to entertainment are suggested for the weekends (Fig. 8). Within

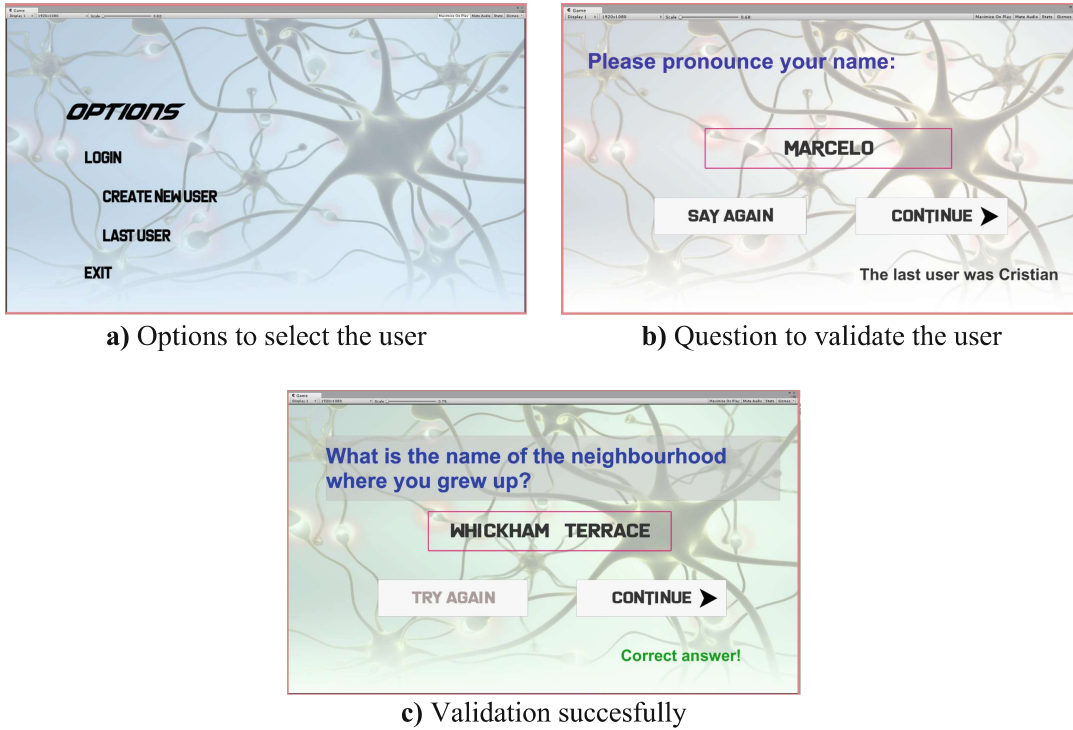


Fig. 7. Welcome windows

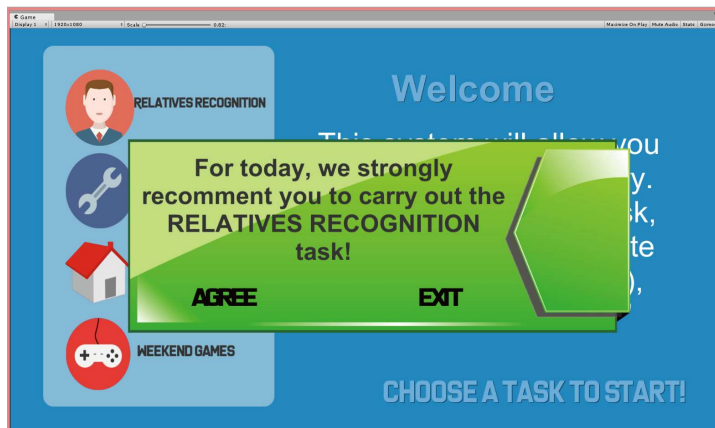
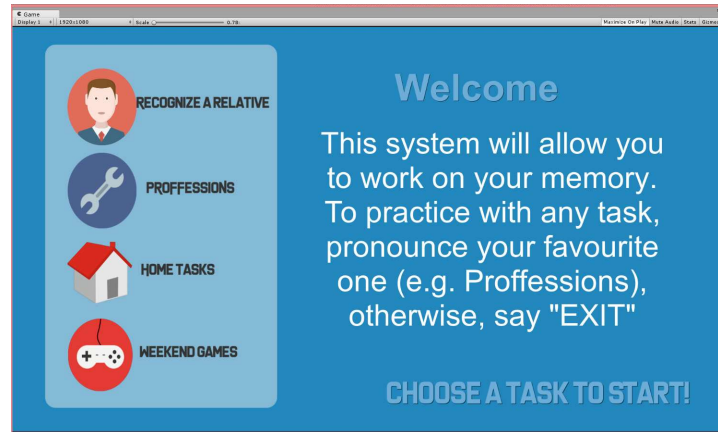


Fig. 8. Recommended task by the application dependent on the day

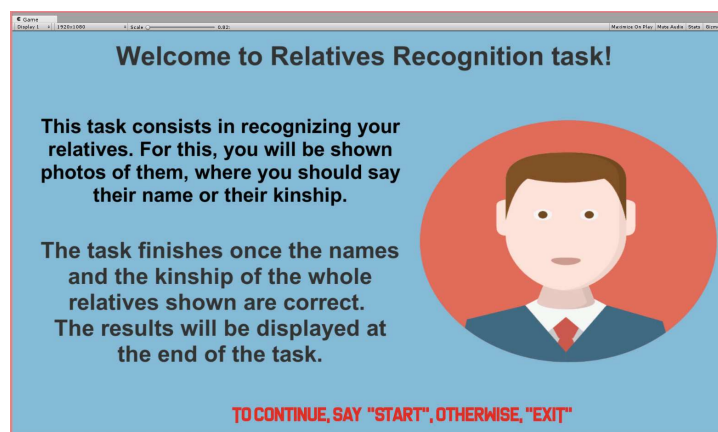
these exercises there are several options: daily tasks, tasks related to professions, relatives recognition, and entertainment tasks. Household chores, such as selecting a set of objects in a market with an assigned amount of money, cloths washing or repairing a piece of furniture, are referred to daily tasks, while tasks related to professions allow choosing a task that may be related to professional activities that the user played in previous years. On the other hand, face recognition is based on information stored in a database, where tagged photographs of people are enclosed to the patient’s profile with the objective of the user citing his name and kinship.



**Fig. 9.** Selectable task menu

Finally, the entertainment tasks are a complement to a set of exercises that may be difficult to execute. Unlike the rest of activities, the tasks of entertaining are based on exercises that the user can execute with the help of the arrangement of cameras and the HTC VIVE that the devices provide, such as tennis, target shooting, dancing, and so on. Figure 9 shows the menu of tasks to be selected, where messages are presented that are placed with the intention of guiding the user throughout the execution of the program.

The results shown are based on two experimental cases, which show the selection of two tasks: face recognition and related to a profession. Both show the execution of a specific task until obtaining results to determine the level of coincidences between the desired and the executed by the patient. In this way, the first experiment receives the activity suggestion, while the second one shows the selection of an additional task to that suggested by the application.



**Fig. 10.** Welcome message to the relative recognition application.



## 5.1 First Experiment

The First experiment is developed after the suggestion of the application, using the database which contains preloaded photographs of people related to the user's profile. The photographs are labeled to know the relationship between the user and the person shown in the photo, appearing in the application at random. Figure 10 shows the welcome message to the application, providing instructions for a successful execution.

At random, the application requests either the name of the person shown on the screen or the degree of kinship with the user (Fig. 11 (a–c)). The level of coincidences between the expected response and the responses generated by the user are counted by the application, showing the results once the questions are concluded (Fig. 11 (d)).

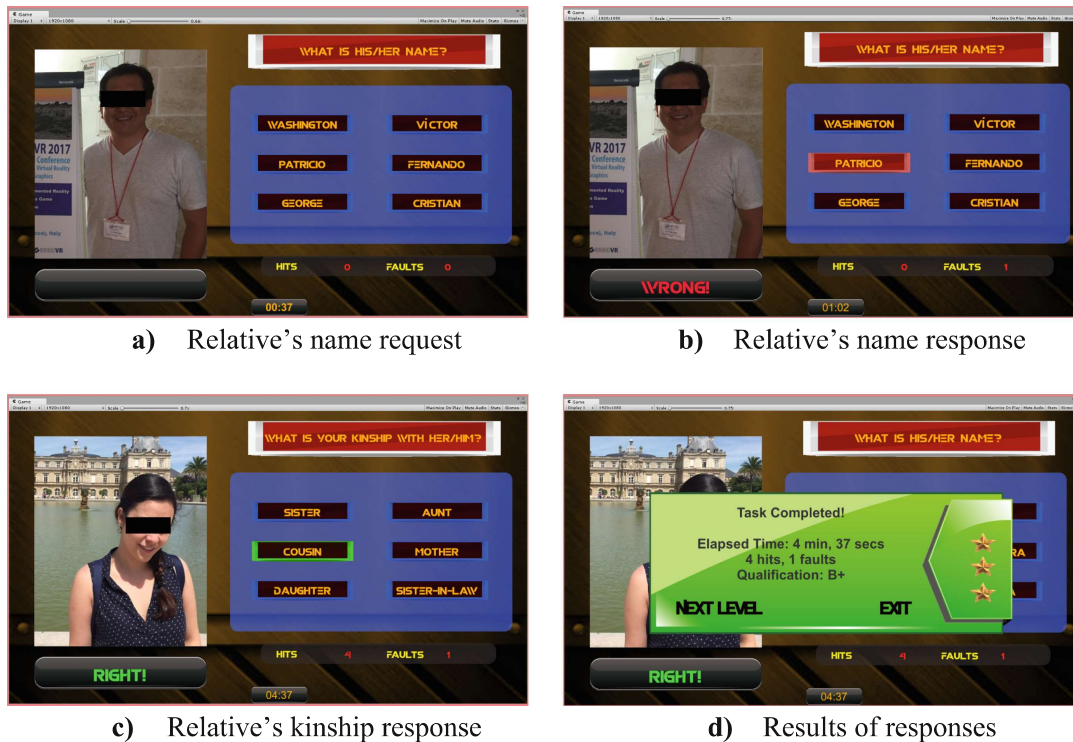
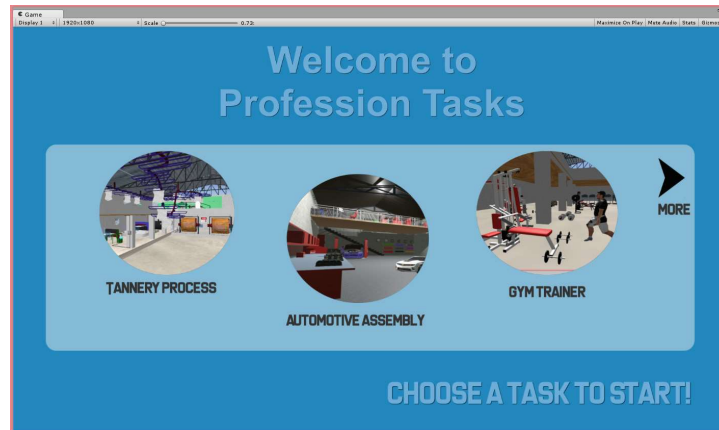


Fig. 11. Execution the relative recognition task.

**Remark 4:** Given the ease of response in the first acknowledgments, the application increases the level of difficulty if the number of hits is high, showing faces of more distant relatives or non-updated photographs of people when selecting the next level.

## 5.2 Second Experiment

Figure 12 shows the text displayed by the graphic engine when selecting work activities. The options are oriented to activities that the user can execute with the help of guides and examples included in the application. In this case, the tannery profession is shown, where the total work scenario is introduced and the places where the machinery, controls, elements, and material necessary to carry out the daily task are



**Fig. 12.** Selection of work activities

indicated (Fig. 13). It is important to emphasize that both this and the first experiment seek to demonstrate the functioning and applicability of the proposed system, but it does not demonstrate results on rehabilitated persons, therefore, the tests are developed by internal collaborators. Future works based on this research will propose to prove the effectiveness of the application.



**Fig. 13.** Tannery scenario

As an example, the objective of the task is to place a quantity of leather inside a drum and wash it. For this, the task is divided into seven stages, executed successively: (a) open the drum to place the material inside the drum, where a door which can be opened through the HTC VIVE controllers is presented; (b) pick the leather pieces up and place them inside the drum; (c) close and secure the drum door to start the washing process; (d) move to the control panel of the machinery and press the power button; (e) verify the operation of the process and wait a short time for the washing process; (f) turn the drum off and wait until it stops completely, and finally, (g) take out the processed leather pieces. The execution of all subtasks are shown in Fig. 14.



**Fig. 14.** Execution of the activity related to professions

**Remark 5:** Based on Literature [13, 14], it has been reported cases of aggressive behaviour in older adults with memory problems who cannot perform basic activities. In order to evaluate the reaction of these users, different avatar are placed in the work environment. Parallel to the main execution, avatars are programmed to develop specific and repetitive tasks, turning the work environment into a natural space that is easy to assimilate.



**Fig. 15.** Results of the task of the second experiment

Finally, a summary of results is shown, where recommendations to improve performance in future executions can be deployed. In this case, Fig. 15 shows a satisfactory execution of the user, at an appropriate time and without major recommendations.

## 6 Conclusions

An application to strengthen the memory of older adults through virtual reality is presented. In order to maintain the level of information retention of a person with memory problems, various environments are programmed, considering scenarios for recognition of relatives, domestic tasks, activities related to professions, and weekend games.

Each of the scenarios includes elements designed in CAD software, which are textured and coloured to recreate real environments, and can be controlled to generate the proposed tasks. Both sound and visual feedback try to achieve an immersion of third level in the user, where the older adult can interact with each of the elements distributed in the scenes. Additionally, speech recognition libraries are included to facilitate access to applications, as well as task evaluators to rate the development of the exercises. Finally, two experimental results are presented, showing the steps to execute the tasks satisfactorily.

**Acknowledgements.** The authors would like to thank to the Corporación Ecuatoriana para el Desarrollo de la Investigación y Academia – CEDIA for the financing given to research, development, and innovation, through the CEPRA projects, especially the project CEPRA-XI-2017-06; *Control Coordinado Multi-operador aplicado a un robot Manipulador Aéreo*; also to Universidad de las Fuerzas Armadas ESPE, Universidad Técnica de Ambato, Escuela Superior Politécnica de Chimborazo, Universidad Nacional de Chimborazo, and Grupo de Investigación en Automatización, Robótica y Sistemas Inteligentes, GI-ARSI, for the support to develop this paper.

## References

1. Inouye, S.K., Westendorp, R.G., Saczynski, J.S.: Delirium in elderly people. *Lancet* **383** (9920), 911–922 (2014)
2. Organization World Health, “World report on ageing and health 2016,” Ageing and life-course, September 2016. <http://www.who.int/mediacentre/factsheets/fs404/en/>. Accessed 25 Mar 2015
3. World Health Organization, “Interesting facts about aging,” Media centre, September 2015. <http://www.who.int/ageing/about/facts/>. Accessed 25 Mar 2018
4. World Health Organization, Mental health of older adults, Media centre, December 2017. <http://www.who.int/mediacentre/factsheets/fs381/en/>. Accessed 26 Mar 2018
5. Sotolongo, P.C., Carrillo, P.C., Carrillo, C.C.: Cognitive impairment in the third age. *Rev. Cuba. Med. Gen. Integral* **20**(5–6), 10–15 (2004)
6. World Health Organization, International Classification of Functioning, Disability and Health, ICF. World Health Organization, vol. 1, no. 1, pp. 1–15 (2001)
7. Gu, J., et al.: Multimorbidity and health-related quality of life among the community-dwelling elderly: a longitudinal study. *Arch. Gerontol. Geriatr.* **74**, 133–140 (2018)
8. Barbosa, H., Castro, A.V., Carrapatoso, E.: Serious games and rehabilitation for elderly adults. *GSI* **6**(1), 275–280 (2018)
9. Andaluz, V.H., Pazmiño, A.M., Pérez, J.A., Carvajal, C.P., Lozada, F., Lascano, J., Carvajal, J.: Training of tannery processes through virtual reality. *Augmented Reality Virtual Reality Comput. Graph.* **10324**(1), 75–93 (2017)
10. Naranjo, C.A., Ortiz, J.S., Álvarez, V.M., Sánchez, J.S., Tamayo, V.M., Acosta, F.A., Proaño, L.E., Andaluz, V.H.: Teaching process for children with autism in virtual reality environments. *Educ. Technol. Comput.* **2017**(1), 41–45 (2017)
11. Andaluz, V.H., Guamán, S., Sánchez, J.S.: Autonomous March control for humanoid robot animation in a virtual reality environment. *Comput. Kinematics* **50**, 70–78 (2017)
12. Pang, H., Kwong, E.: Considerations and design on apps for elderly with mild-to-moderate dementia. *Inf. Networking (ICOIN)* **2015**(1), 348–353 (2015)
13. Brodaty, H., Low, L.: Aggression in the elderly. *Eur. PMC* **64**(4), 36–43 (2016)
14. Power, K.: Experiences of aggression and violence across dementia and adult acute psychiatric facilities. University of Warwick, England (2016)





## **VI. Effects of immersive virtual reality on the heart rate of athlete's warm-up.**

### **Referencia:**

**Varela-Aldás, J.,** Palacios-Navarro, G., García-Magariño, I., & Fuentes, E. M. (2019). Effects of immersive virtual reality on the heart rate of athlete's warm-up. *In International Conference on Augmented Reality, Virtual Reality and Computer Graphics* (pp. 175-185). Springer, Cham.



# Effects of Immersive Virtual Reality on the Heart Rate of Athlete's Warm-Up

José Varela-Aldás<sup>1,2</sup>(✉) , Guillermo Palacios-Navarro<sup>2</sup> ,  
Iván García-Magariño<sup>3</sup> , and Esteban M. Fuentes<sup>1</sup> 

<sup>1</sup> Grupo de Investigación en Sistemas Industriales, Software y Automatización SISAu, Facultad de Ingeniería y Tecnologías de la Información y la Comunicación, Universidad Tecnológica Indoamérica, Ambato, Ecuador  
josevarela@uti.edu.ec, tebanfuentes@gmail.com

<sup>2</sup> Department of Electronic Engineering and Communications, University of Zaragoza, Zaragoza, Spain  
guillermo.palacios@unizar.es

<sup>3</sup> Department of Software Engineering and Artificial Intelligence, Complutense University of Madrid, Madrid, Spain  
igarciam@ucm.es

**Abstract.** An adequate warm-up prior to intensive exercise can bring benefits to athletes, these requirements may vary depending on the physical activity and the training needs. The immersive virtual reality could have benefits in the warm-up and it can be determined by physiological data of the athlete. This work presents a mobile virtual reality application to stimulate the warm-up of an athlete using a standard treadmill, where the developed application is composed of a pleasant and stimulating environment. A Smartphone and the Gear VR are used as an HMD device, and wireless headphones are placed in the users, in addition, the heart rate of the athletes is monitored using a Polar H7 sensor. Experimental results are obtained in athletes with similar characteristics and conditions, identified a direct relation of the virtual environment with the pulsations per minute (ppm), denoting pulsations greater than usual in case of the stimulating environment and lower pulsations for the pleasant environment. Finally, a usability test is performed that shows the level of sociability of the system.

**Keywords:** Virtual reality · Immersion · Heart rate · Warm-up · Usability

## 1 Introduction

Immersive virtual reality offers the possibility of comparing the human response in activities and processes within virtual environments with respect to situations presented in the real world, in order to analyze the perception, preference, and behavior of the user. The concurrent areas in the use of this technology are medicine, psychotherapy, and education, advantageously these immersion systems are available to almost all researchers [1]. In medicine, the user can improve the learning processes of the human anatomy, reviewing the internal composition of human parts, including complex

elements of the brain [2]. It is also possible to study decision-making processes by applying subjective and objective evaluation techniques [3]. On the other hand, virtual neurological rehabilitation allows the patient to improve their cognitive functions even when the lesion is in the subacute period [4] and in motor rehabilitation when the patient has lost mobility, the positive effects of these applications have been demonstrated using different methods [5]. In addition, virtual reality has allowed diagnosing physical and psychological states; studies determine the consumption of methamphetamines through social virtual environments and analyzing neurophysiological signals [6]; stress levels are qualified by the variability of the heart rate in situations of tension within immersive virtual environments [7]. The development of these applications requires a correct insertion of the immersion components, as well as an adequate coherence to the responses of the virtual environment, studies show that discomfort occurs in the user due to lack of coordination [8].

To determine the benefits and usability of a virtual reality system, it is necessary to rely on surveys and physiological data that validate this information. Current technology has facilitated acquiring sensory information from the user, reducing the size of the sensors, new communication devices, and connectivity, allowing the use of multiple contact devices which are widely used in medicine [9]. The data commonly recorded are heart rate, systolic blood pressure, diastolic blood pressure, electroencephalography, core temperature, eye movement, and so forth. [10], These data allow to measure states of relaxation and stress, especially in situations of great pain and discomfort [11]. Several proposals manage to quantify the concentration of the user through real-time information and some works manage to design telemetric monitoring systems for patients [12, 13].

Sport is a human activity with a high degree of influence on the quality of life, for this reason there are multiple virtual reality games to encourage exercise and study the user's physical responses, thus, Exergame includes the virtual tracking of the body movements of the user, combining physical activity and visual feedback, achieving favorable responses according to studies [14]. Soccer experts have evaluated first-person immersive virtual training systems [15], recommending its use. To study the daily exercise or any sport activity, several data of the user-application system are required, from knowing the movements made in real time to measuring the physiological conditions affected [16], where it had seen that the more immersive the application of virtual reality, the greater stimuli are generated in the human body and reactions similar to those produced by real exercises are achieved [17]. An element of incidence are the landscapes which appear in the virtual environment, because physical activities are usually carried out in confined places, virtual training allows to improve the comfort of the user and highlight the benefits of exercising in spaces of reality virtual [18]. The intensity of exercise in active virtual reality games has been studied by oxygen consumption and heart rate, obtaining important data to determine the metabolic rate of the activity and making decisions by specialists according to the requirements [19]. Finally, the users of a football training software with immersive virtual reality presented performance improvements of up to 30% in 3 days of evaluation [20].

This work performs the analysis of warm-up on a treadmill using visual stimulation using immersive virtual environments. The purpose is to stimulate the walk by

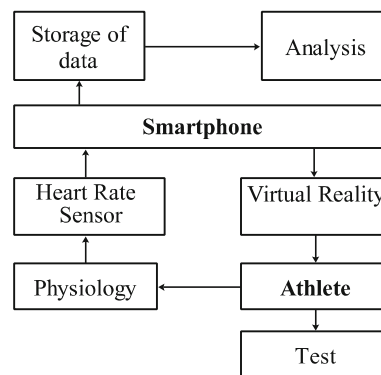


presenting landscapes and measuring the heart rate in each case, the application is developed using the Gear VR and the raw data is acquired using the Polar H7 sensor. The document has been organized in the following manner: (ii) *formulation of the problem*, the problem to be solved is analyzed and a proposed structure is presented; (iii) *Proposed system*, the components of the system are detailed; (iv) *Virtual environment development*, the implementation of virtual environments is described; (v) *Results*, the results obtained through experimentation and applying a usability test are presented; (vi) *Conclusions*, the final proposals are presented.

## 2 Formulation of the Problem

In physical training, the first step recommended before running exercises is warm-up, where the purpose is to prepare the muscular system for more violent or forceful movements. Technically, most athletes do not have control of the level of warm-up required for their training and the components of gyms and sports areas do not motivate the proper development of this stage of training. In professional sports, a careless warm-up can cause serious injuries and affect the health of the athlete. On the other hand, an inadequate warm-up could generate discomfort in the later phase, affecting performance. For these cases, improving the environment surrounding of the athlete could generate changes in their performance, and it is possible to influence him/her. The level of involvement of the immersive virtual reality in the warm-up phase of an athlete depends on the recreated virtual components and the devices used, this influence could be positive or negative in the user, so it is important to design properly the virtual environments to be used.

The effect produced by the virtual environment in an athlete while performing physical warm-up on a treadmill can be analyzed through a survey or using physiological data. This information can be used by specialists who make the decisions that best suit the athlete. In this context, it is proposed to develop a virtual reality application to stimulate warm-up using a treadmill while acquiring heart rate data in the user, as shown in Fig. 1. The HMD device works by means of a smartphone, using additionally a waterproof belt type sensor called Polar H7.

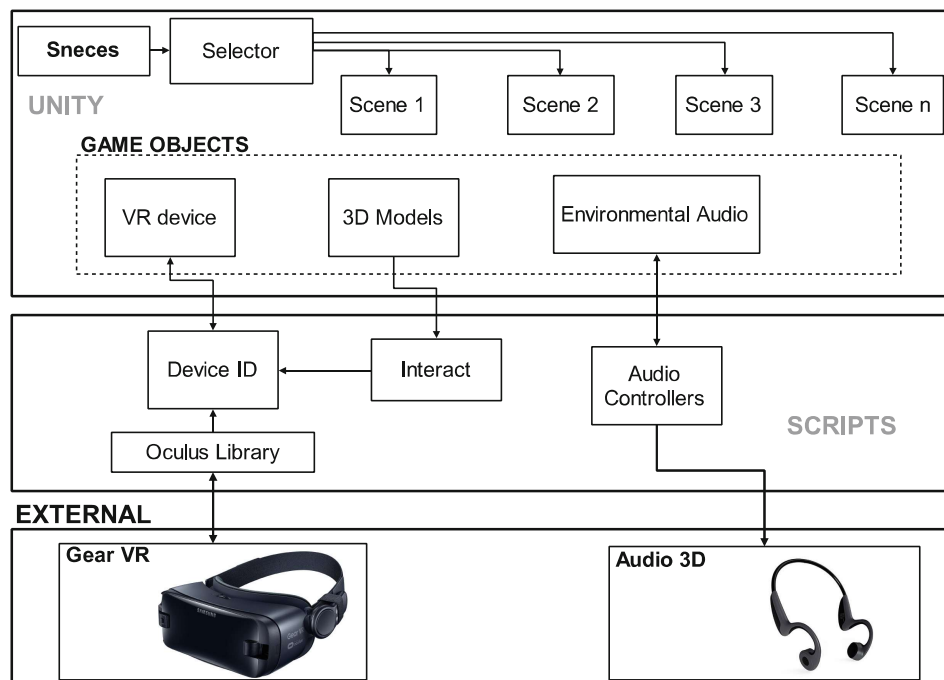


**Fig. 1.** Proposed structure

The implementation of virtual environments aims to stimulate the athlete through a landscape of relaxation and excitement, influencing the heart rate and motivating the mood of the user. The application can be used on a treadmill or controlled trips in fully structured areas. Finally, the information collected is compared to normal warm-up to determine the variations.

### 3 Proposed System

The structure of the proposed system is split into three groups: the game objects inserted in Unity, the control scripts for the virtual elements, and the external input and output devices. Figure 1 shows the structure of the system, where each component is presented (Fig. 2).



**Fig. 2.** System components

In Unity there are the scenes of the virtual reality environment, depending on whether it is necessary to stimulate the state of relaxation or excitement. In this stage, the 3D models which make up the landscape observed by the athlete are inserted, the scenes are independent and have their respective models; likewise, the virtual reality device is defined by a game object which allows its operation, and finally, there are game objects linked to spatial audio sources.

On the other hand, scripts allows communication between Unity scenes and external devices (HMD and headphones); they coordinate the functions of the game objects and the actions of the game; and the oculus libraries manage the Gear VR

recourses. The input devices are the internal sensors of the Smartphone and the output devices are the mobile virtual reality glasses and the wireless headphones.

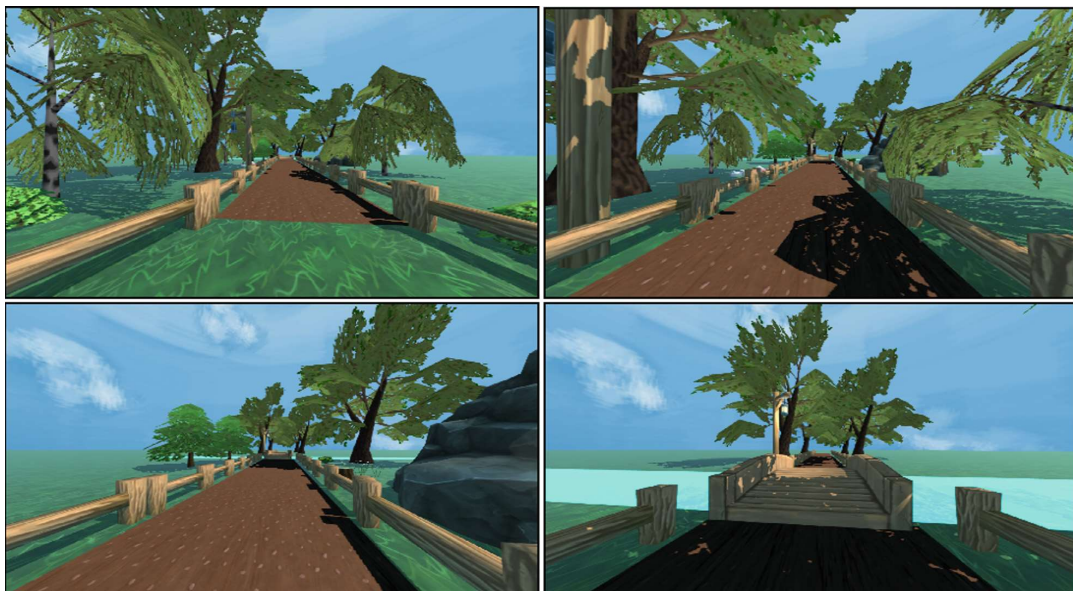
For the acquisition of heart rate data, an additional mobile application which receives the sensor information is used. The device used is the polar H7, this sensor is characterized by its robustness and resistance to conditions of almost any sports activity, including swimming. Figure 3 illustrates the heart rate sensor used.



**Fig. 3.** Heart rate sensor

#### **4 Virtual Environment Development**

Two types of environments are developed to implement the application and the functions of the virtual elements. The scene of relaxation consists of sunny days and dense vegetation, and the stimulating environment with dark scenes.



**Fig. 4.** Scene of Relaxation

Figure 4 shows the images of the relaxation place, a trail-like environment for the athlete's walk surrounded by relaxing attractions. The components have been entered using prefabs from multiple assets and have been placed in the scene by position parameters and rotation parameters of the scene inspector.

Figure 5 shows the images of the stimulating environment, an abandoned place which is in flames. The components have been entered in a similar way to the relaxation area and fire effects have been inserted using the Unity particle system.



**Fig. 5.** Excitement environment

Regarding the movement of the user, a control script is created which allows the movement of the virtual camera in the walking area, and through *player.transform.position*, the displacement has been designed in a cyclical manner, that is, when the player reaches the end of the route, he/she is located again at the beginning.

## 5 Results

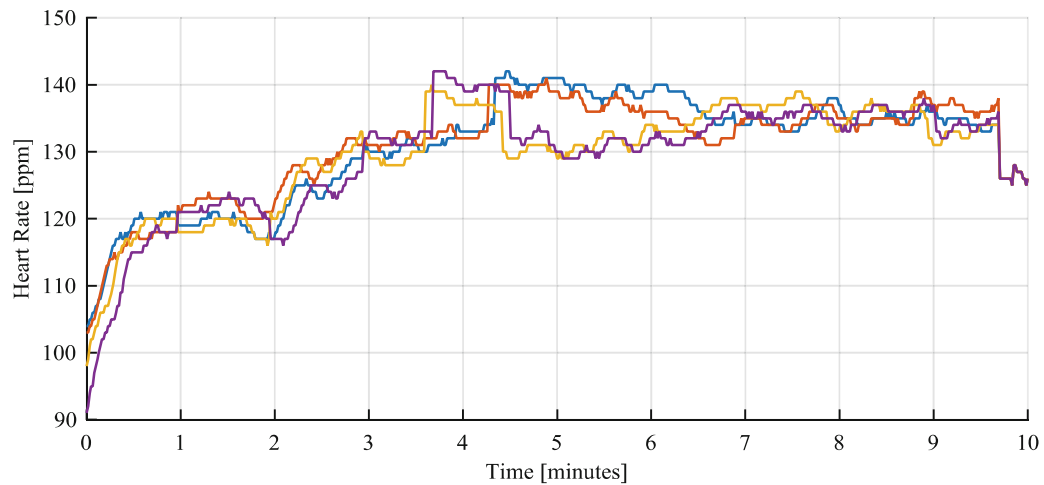
Next, the results obtained using immersive virtual reality in the physical warm-up phase of athletes using a treadmill are presented. The results are evaluated using the data acquired by the Polar H7 sensor and applying a usability test of the application. Given the random and constant movement due the sport activities, for the visual output is used a Galaxy S8+ Smartphone with Gear VR, while for the output are used the Z8 wireless headphones. Figure 6 shows an experienced user the virtual reality system.

The experiments are carried out in 4 athletes who regularly attend the gymnasium of the Universidad Tecnológica Indoamérica, all male between 22 and 24 years old. The tests are performed on a standard treadmill at a constant speed of 2.5 km/h and with a duration of 10 min. In the first test, the users perform the exercise without the



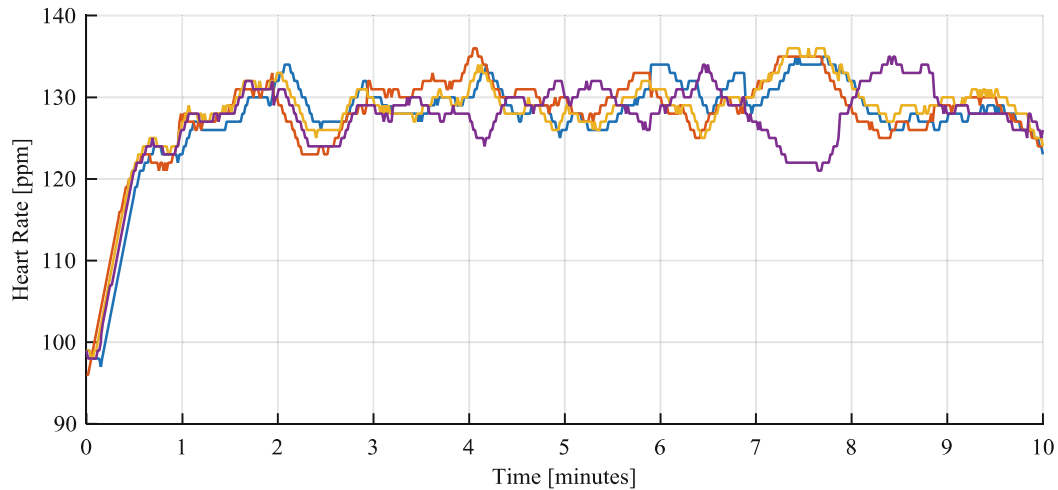
**Fig. 6.** Athlete testing the system

Gear VR, and their cardiac responses are monitored, obtaining the data of Fig. 7, where it is observed that the athletes reach maximum peaks of 143 ppm in this period, maintaining a range of pulsations between 128 and 143 ppm in the stationary stage.



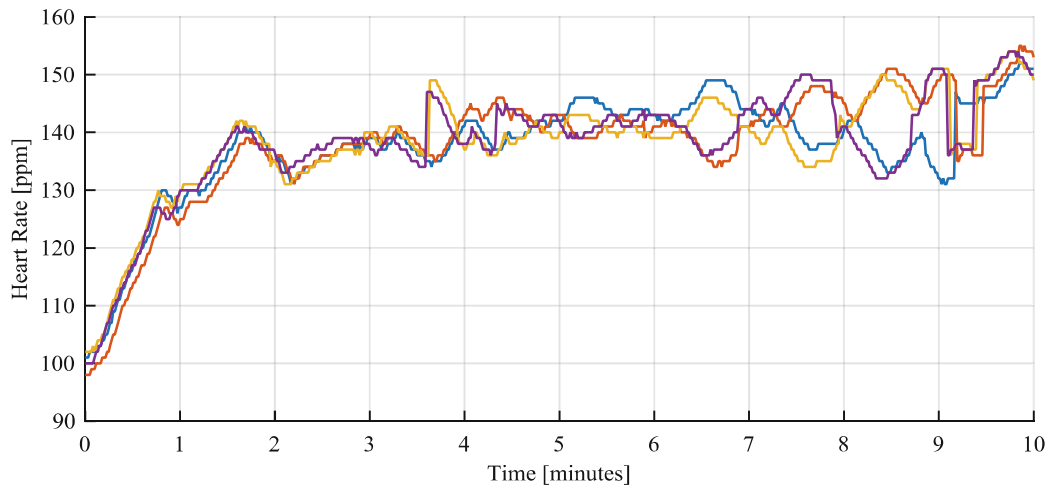
**Fig. 7.** Heart rate without virtual environment

Evaluating the scenes of relaxation, the individuals generated the cardiac pulses of Fig. 8, observing a maximum heart rate of 136 ppm, and maintained a range of pulsations between 122 and 136 ppm in the stationary phase, which indicates a reduction of heart rate respect to normal exercise conditions, due to the effect of relaxing place on the walk.



**Fig. 8.** Heart rate with virtual scenes of relaxation

From the experiment with the stimulating virtual environment, the heart rate signals of Fig. 9 were obtained, showing a maximum heart rate of 154 ppm, and a range of heart beats between 131 and 154 ppm in a permanent period, which indicates an increase in average heart rate with respect to normal walking conditions.



**Fig. 9.** Heart rate with virtual excitement environment

Figure 10 shows a comparison of the previous experiments, observing a greater heart rate in the case of experiencing a virtual environment of excitement, and lower pulsations when individuals visualize the virtual environment of relaxing. Demonstrating a clear influence of the immersive virtual reality in the physical warm-up with the conditions exposed in this work.

To evaluate the usability of this application, a SUS test is applied, widely used in mobile applications, for which the procedures detailed in [21] are used. Table 1 shows the results of the test applied in the 4 test subjects, obtaining a total of 27.25 and

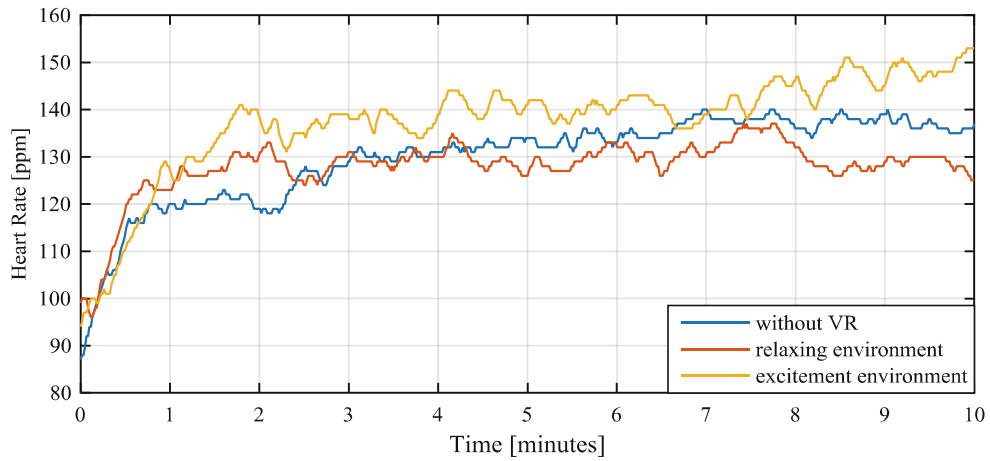


Fig. 10. Comparison of heart rate responses

Table 1. Test SUS results

Question	Score 1	Score 2	Score 3	Score 4	Mean	Operation
I think I would like to use this system frequently	2	3	2	2	2.25	1.25
<b>I find this system unnecessarily complex</b>	<b>1</b>	<b>1</b>	<b>2</b>	<b>1</b>	<b>1.25</b>	<b>3.75</b>
I think the system is easy to use	4	4	4	4	4	3
<b>I think you would need technical support to make use of the system</b>	<b>1</b>	<b>2</b>	<b>2</b>	<b>3</b>	<b>2</b>	<b>3</b>
I find the various functions of the system quite well integrated	3	4	2	3	3	2
<b>I have found too much inconsistency in this system</b>	<b>2</b>	<b>1</b>	<b>1</b>	<b>2</b>	<b>1.5</b>	<b>3.5</b>
I think most people would learn to make use of the system quickly	4	3	4	4	3.75	2.75
<b>I found the system quite uncomfortable to use</b>	<b>2</b>	<b>2</b>	<b>2</b>	<b>1</b>	<b>1.75</b>	<b>3.25</b>
I have felt very safe using the system	2	2	2	1	1.75	0.75
<b>I would need to learn a lot of things before I can manage the system</b>	<b>1</b>	<b>1</b>	<b>1</b>	<b>1</b>	<b>1</b>	<b>4</b>
<b>Total</b>						<b>27.25</b>

multiplying by the factor 2.5, a final assessment of 68.125 is obtained, which can be considered as in the acceptance limit, indicating that improvements are required for the recurrent use of the system. The test shows resistance to the use of the application on a frequent basis by users, they also consider that virtual reality functionalities have not been well integrated, and they do not feel safe using the system.

## 6 Conclusions

The work presents the influence of an immersive virtual reality application in the physical warm-up phase of an athlete using a standard treadmill. For this purpose, a virtual environment of relaxation and another virtual scenario of excitement are implemented, the Gear VR is used to perform the experimental tests and the heart rate is monitored by a specialized sensor. The virtual environments are developed using the basic characteristics of Unity, considering that the user experiment in first person, where wireless sports headphones are used to increase the level of immersion.

The results obtained show notable differences in the heart rate of the athletes, starting from the analysis under normal training conditions which allow to compare the effects of the system on the user. The virtual environment of relaxation maintains a heart rate lower than the normal and the exciting virtual environment produces a higher heart rate, conditions which can be used by a specialist to obtain the desired effects in the subsequent intensive training. In addition, the usability of the applications is evaluated, demonstrating that some shortcomings in the system can be improved, mainly related to comfort and user satisfaction.

## References

1. Smith, J.W.: Immersive virtual environment technology to supplement environmental perception, preference and behavior research: a review with applications. *Int. J. Environ. Res. Public Health*. **12**, 11486–11505 (2015)
2. Izard, S.G., Juanes Méndez, J.A.: Virtual reality medical training system. In: *ACM International Conference Proceeding Series*. pp. 479–485. Association for Computing Machinery, Salamanca (2016)
3. De-Juan-Ripoll, C., Soler-domínguez, J.L., Guixeres, J., Contero, M., Álvarez Gutiérrez, N., Alcañiz, M.: Virtual reality as a new approach for risk taking assessment. *Front. Psychol.* **9**, 1–8 (2018)
4. Dahdah, M.N., Bennett, M., Prajapati, P., Parsons, T.D., Sullivan, E., Driver, S.: Application of virtual environments in a multi-disciplinary day neurorehabilitation program to improve executive functioning using the Stroop task. *NeuroRehabilitation* **41**, 721–734 (2017)
5. San Luis, M.A. V., Atienza, R.O., San Luis, A.M.: Immersive virtual reality as a supplement in the rehabilitation program of post-stroke patients. In: *International Conference on Next Generation Mobile Applications, Services, and Technologies*, pp. 47–52. IEEE Computer Society, Cardiff, Wales (2016)
6. Wang, M., Reid, D.: Using the virtual reality-cognitive rehabilitation approach to improve contextual processing in children with autism. *Sci. World J.* **2013**, 9 (2013)



7. Ham, J., Cho, D., Oh, J., Lee, B.: Discrimination of multiple stress levels in virtual reality environments using heart rate variability. In: Proceedings of the Annual International Conference of the IEEE Engineering in Medicine and Biology Society, EMBS, pp. 3989–3992. Institute of Electrical and Electronics Engineers Inc., Island (2017)
8. Skarbez, R., Brooks, F.P., Whitton, M.C.: Immersion and coherence in a stressful virtual environment. In: Proceedings of the ACM Symposium on Virtual Reality Software and Technology, VRST, pp. 1–11. Association for Computing Machinery, Tokyo (2018)
9. Yetisen, A.K., Martinez-hurtado, J.L., Khademhosseini, A., Butt, H.: Wearables in medicine. *Adv. Mater.* **30**, 1706910 (2018)
10. Da SiLva Neves, L.E., et al.: Cardiovascular effects of Zumba performed in a virtual environment using XBOX kinect. *J. Phys. Ther. Sci.* **27**, 2863–2865 (2015)
11. Gerber, S.M., et al.: Visuo-acoustic stimulation that helps you to relax: A virtual reality setup for patients in the intensive care unit. *Sci. Rep.* **7**, 1–10 (2017)
12. Bombeke, K., et al.: Do not disturb: psychophysiological correlates of boredom, flow and frustration during VR gaming. In: Schmorow, D.D., Fidopiastis, C.M. (eds.) AC 2018. LNCS (LNAI), vol. 10915, pp. 101–119. Springer, Cham (2018). [https://doi.org/10.1007/978-3-319-91470-1\\_10](https://doi.org/10.1007/978-3-319-91470-1_10)
13. Kohani, M., Berman, J., Catacora, D., Kim, B., Vaughn-cooke, M.: Evaluating operator performance for patient telemetry monitoring stations using virtual reality. In: Proceedings of the Human Factors and Ergonomics Society 58th Annual Meeting, pp. 2388–2392. Human Factors an Ergonomics Society Inc., Chicago (2014)
14. Schmidt, S., Ehrenbrink, P., Weiss, B., Kojic, T., Johnston, A., Sebastian, M.: Impact of virtual environments on motivation and engagement during exergames. In: International Conference on Quality of Multimedia Experience, pp. 1–6. Institute of Electrical and Electronics Engineers Inc., Sardinia (2018)
15. Gulec, U., Yilmaz, M., Isler, V., Connor, R.V.O., Clarke, P.M.: Computer Standards & Interfaces a 3D virtual environment for training soccer referees. *Comput. Stand. Interfaces.* **64**, 1–10 (2018)
16. Yoo, S., Gough, P., Kay, J.: VRFit : an interactive dashboard for visualising of virtual reality exercise and daily step data. In: ACM International Conference Proceeding Series, pp. 229–233. Association for Computing Machinery, Melbourne (2018)
17. Vogt, T., Herpers, R., Askew, C.D., Scherfgen, D., Strüder, H.K., Schneider, S.: Effects of exercise in immersive virtual environments on cortical neural oscillations and mental state. *Neural Plast.* **2015** (2015)
18. Solignac, A.: EVE : exercise in virtual environments. In: IEEE Virtual Reality Conference, pp. 287–288. Institute of Electrical and Electronics Engineers Inc., Arles (2015)
19. Gomez, D.H., Bagley, J.R., Bolter, N., Kern, M., Lee, C.M.: Metabolic cost and exercise intensity during active virtual reality gaming. *GAMES Heal. J. Res. Dev. Clin. Appl.* **7**, 310–316 (2018)
20. Huang, Y., Churches, L., Reilly, B.: A case study on virtual reality american football training. In: ACM International Conference Proceeding Series. pp. 1–5. Association for Computing Machinery, Laval (2015)
21. Quevedo, W.X., et al.: Market study of durable consumer products in multi-user virtual environments. In: De Paolis, L.T., Bourdot, P. (eds.) AVR 2018. LNCS, vol. 10850, pp. 86–100. Springer, Cham (2018). [https://doi.org/10.1007/978-3-319-95270-3\\_6](https://doi.org/10.1007/978-3-319-95270-3_6)





## **VII. Immersive Virtual Reality App to Promote Healthy Eating in Children**

### **Referencia:**

Fuentes, E. M., **Varela-Aldás, J.**, Palacios-Navarro, G., & García-Magariño, I. (2020). Immersive Virtual Reality App to Promote Healthy Eating in Children. In *International Conference on Human-Computer Interaction* (pp. 9-15). Springer, Cham.



# Immersive Virtual Reality App to Promote Healthy Eating in Children

Esteban M. Fuentes<sup>1</sup> , José Varela-Aldás<sup>1,2</sup> ,  
Guillermo Palacios-Navarro<sup>2</sup> , and Iván García-Magariño<sup>3</sup> 

<sup>1</sup> Grupo de Investigación en Sistemas Industriales, Software y Automatización SISAu, Facultad de Ingeniería y Tecnologías de la Información y la Comunicación, Universidad Tecnológica Indoamérica, Ambato, Ecuador  
tebanfuentes@gmail.com, josevarela@uti.edu.ec

<sup>2</sup> Department of Electronic Engineering and Communications,  
University of Zaragoza, Saragossa, Spain  
guillermo.palacios@unizar.es

<sup>3</sup> Department of Software Engineering and Artificial Intelligence,  
Complutense University of Madrid, Madrid, Spain  
igarciam@ucm.es

**Abstract.** An immersive virtual reality application was developed as a serious game to support children on their decisions about food, the system was composed by the Gear VR (Viewer and controller), and a phone which contains the mobile application developed in Unity, providing the immersive environment, the platform was based on a path where the player has to go through it choosing between different sort of meals and also between different physical activities, the effect of balanced diet plus adequate physical activity seems reflected on the avatar previously chosen by the user, the app was tested on 12 children between 8 and 10 years old during one week, children participated on the study after receiving an informed consent, analyzing the tendencies of food choice on children before and after, a notorious positive effect could be seen on the users according to the avatar analyzed at the end of the round, besides a System usability ore was also applied to evaluate the degree of usability of the app, reaching a ore of 88.33% which rates the app as very usable, this results were even better than what was planned at the beginning of the experience.

**Keywords:** Virtual reality · Nutrition · Children · Serious game

## 1 Introduction

Food intake nowadays it's been taken in count as a very important part of public health even on developed countries due to the influence which has with the creation of tissues along the children growing up process, besides the influence over the metabolism which can have the food intake with a huge caloric content, we have to take in count that one of the major health problems that the world deals with is obesity or some problems linked to the diet habits. Lack of physical activity plus a very rich carbohydrate, sugar or fat

food intake through fast food, junk food, sweets or pastries are the perfect recipe to develop health troubles and even worse if it is between young ages [1–5].

The best way to deal with health troubles such as obesity or children diabetes is education, but taking in count that technology is all the way around us, why not to take advantage of it and its positive proved effects over young population and to use it as a support tool, for example the Virtual Reality which is one of the new tendencies and has converted on a main trend specially when talking about video games or different sorts of therapy, so it is been widely applied on different topics than nutrition mainly on cerebral palsy [6, 7], but could have an amazingly positive effect over children at the moment of making food choices [8–14].

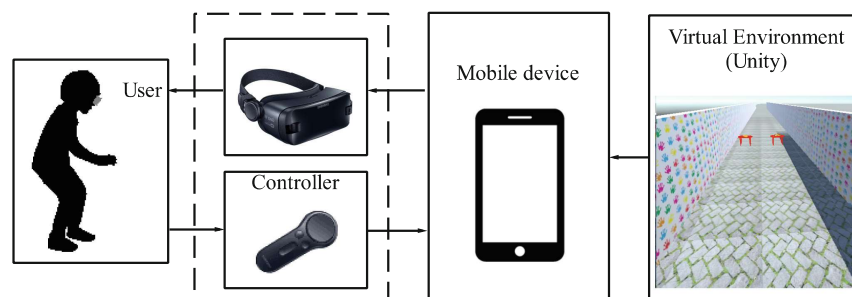
This work describes an immersive virtual reality application to encourage healthy eating in children on a friendly way, using the Gear VR as a head-mounted display (HMD) device. The results present the virtual environment developed and the children’s response.

## 2 Materials and Methods

For the development of the present study a previous informed consent was requested to the parents of the participant children, the immersive virtual reality application was performed on 12 children between 8 and 10 years of both genders, to whom a questionnaire of food preferences was applied before and after using the virtual reality system, for a week, the motivation for the participation was mainly the use of technology and the novelty of the device for the children use.

The objective was to develop a serious game which allows the user, to make decisions about food intake and relate it to its effects over an avatar, the user in this case was focused on children and the platform let the child to choose between two food options, consequently, the avatar seems to be affected physically and emotional according to the food intake or even related to the physical activity that is another variable which affects the state of the avatar such as the old virtual pets

The Fig. 1 presents the system components, where the child interacts with the virtual reality application using the Gear VR (Viewer and controller), in addition, a phone contains the mobile application developed in Unity which is going to provide the immersive environment.



**Fig. 1.** Components of the Immersive virtual reality application

The game consists of a corridor platform to be followed while encountering the different feeding options, the user's interaction with the virtual environment was carried out using a handheld controller and the movements of the user are made on first person using the touchpad, when the user finds the foods, a selection laser is enabled which allows to point towards the desired food, and is finally chosen by pulling the trigger of the hand controller; as explained before the choice can be taken from two types of meals, one characterized as healthy food such as vegetables, fruits and dishes with balanced proportions of nutrients (carbohydrates, vitamins, proteins) that can be understood at simple eye, on the other side we can find junk food, such as French fries, pizza, hamburgers and hyper caloric foods.

As a plus we can find through the path some physical activities characterized by games where children can have body movement and some fun, then the realization of these activities will be reflected also on the avatars shape and mood.

The avatar is presented in the upper right of the user's view as an image of a boy or girl (according to the previous configuration), and changes its appearance with the user's decisions along the course of the tour. Principal effects when choosing junk food, can be seen as illness symptoms over the child avatar, nuanced by overweight by the shape of the avatar, sadness expressed by facial expressions and darkness on the environment, progressively; on the other side, when choosing healthy foods, the avatar has a robust strong shape, healthy and happy appearance related with the facial expression of the avatar and a shiny environment. Additionally, the avatar image uses red, orange and green background colors to highlight in health status; bad, regular and good, respectively.

A System Usability ale (SUS) was employed to each child with the help of their own parents, SUS was applied to verify or in our case, to define the usability of the Immersive Virtual reality application for the use of children [15–17].

### 3 Results

System tests were performed over children between 8 to 10 years, Fig. 2 presents a girl using the application (left) and the virtual reality environment (right).

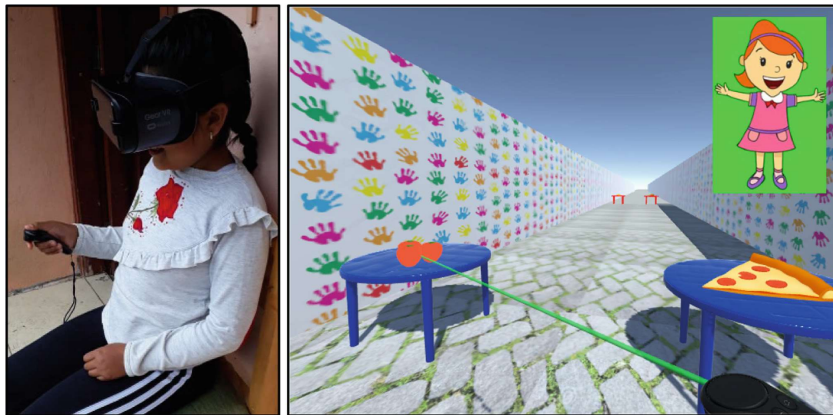


Fig. 2. Immersive virtual reality test application

The proposal was evaluated by 12 children with an average age of 9 years, to whom a questionnaire of food preferences was applied before the use of the application where was clear the preference for non-healthy foods and low interest for physical activities was notorious (Table 1).

**Table 1.** Responses collected before de Immersive virtual reality test application

Question	Sc1	2	3	4	5	6	7	8	9	10	11	12	Count	%
When you are hungry, ¿What do you think is healthier?:														
Plate of meat, salad, rice, sauce	1												1	8
Hot dog, French fries		1	1	1	1	1	1	1	1	1	1	1	11	92
When you are thirsty ¿What would you prefer?														
Fruit juice/water	1		1	1				1					4	33
Cola, powder juice, ice tea		1			1	1	1		1	1	1	1	8	67
When you will get a snack, ¿What do you think is better for your health?														
Fruit				1					1		1		3	25
Potato chips, cookies	1	1	1		1	1	1	1		1		1	9	75
On your Spare Time ¿What would you prefer?														
Stay in Bed/watch TV	1	1				1		1			1		5	42
Go to exercise, play sports			1	1	1		1		1	1		1	7	58

To analyze the effect after using the virtual reality system for a week, the data collected is presented in the Table 2. where a highly notorious change can be seen, in a good way children accept and differentiate between what is tasty but certainly not that healthy as nutritive food specially o the snack where the 100% decided to choose a fruit.

**Table 2.** Responses collected after de Immersive virtual reality test application

Question	Sc1	2	3	4	5	6	7	8	9	10	11	12	Count	%
When you are hungry, ¿What do you think is healthier?														
Plate of meat, salad, rice, sauce	1	1	1	1	1	1		1		1	1	1	10	83
Hot dog, French fries							1		1				2	17
When you are thirsty ¿What would you prefer?														
Fruit juice/water	1		1	1		1		1		1	1		7	58
Cola, powder juice, ice tea		1			1		1		1			1	5	42
When you will get a snack, ¿What do you think is better for your health?														
Fruit	1	1	1	1	1	1	1	1	1	1	1	1	12	100
Potato chips, cookies													0	0
On your spare time, ¿What would you prefer?														
Stay in Bed/watch tv		1						1			1		3	25
Go to exercise, play sports	1		1	1	1	1	1		1	1		1	9	75

In addition, application data was obtained regarding the selection of food in the game. The results showed a tendency to choose healthier foods as they use the application, although at first they preferred the most harmful foods for health related to good taste and lack of interest by physical activities (Table 3).

**Table 3.** Differences on the children choices before and after the Immersive virtual reality test application

Question	Before (%)	After (%)	Dif. (%)
When you are hungry, ¿What do you think is healthier?			
Plate of meat, salad, rice, sauce	8	83	75
Hot dog, French fries	92	17	-75
When you are thirsty, ¿What would you prefer?			
Fruit juice/water	33	58	25
Cola, powder juice, ice tea	67	42	-25
When you will get a snack, ¿What do you think is better for your health?			
Fruit	25	100	75
Potato chips, cookies	75	0	-75
On your spare time, ¿What would you prefer?			
Stay in Bed/watch tv	42	25	-17
Go to exercise, play sports	58	75	17

The application of the SUS showed results even better than expected, being an Immersive virtual reality application characterized as very usable (88.33%) data was collected and presented on the Table 4, which includes the Scores for every user, the application of the SUS was made with the help and presence of the parent of every child and confirmed that the application was very friendly with the user and generated a good impact.

**Table 4.** Scores obtained by the SUS application and the estimated SUS.

Question	Sc1	2	3	4	5	6	7	8	9	10	11	12	Mean	Operation
1. I think I would like to use this system frequently	5	4	3	4	5	3	3	5	4	4	4	3	3,92	2,92
2. I find this system Unnecessarily complex	1	2	1	2	1	1	2	2	1	2	1	2	1,5	3,5
3. I think the system is easy to use	5	5	4	5	4	5	4	5	4	4	4	5	4,5	3,5
4. I think you would need technical support to make use of the system	1	1	1	1	1	1	1	1	1	1	1	1	1	4

(continued)

**Table 4.** (continued)

Question	Sc1	2	3	4	5	6	7	8	9	10	11	12	Mean	Operation
5. I find the various functions of the system quite well integrated	4	5	5	4	4	5	3	4	5	4	4	4	4,25	3,25
6. I have found too much inconsistency in this system	1	1	1	1	1	1	1	1	1	1	1	1	1	4
7. I think most people would learn to make use of the system quickly	5	5	5	5	5	5	5	5	5	5	5	5	5	4
8. I found the system quite uncomfortable to use	1	1	2	1	1	2	2	1	1	2	1	1	1,33	3,67
9. I have felt very safe using the system	5	4	4	5	4	6	3	4	5	4	5	5	4,5	3,5
10. I would need to learn a lot of things before I can manage the system	1	2	3	1	1	2	3	3	2	3	2	1	2	3
													Add	35,33
													Factor	2,5
													SUS	<b>88,33</b>

## 4 Conclusions

Due to globalization, trends on food intake are going favorably to the consumption of hyper caloric diets. The current food trend is to consume fast food foods harmful to health, so it is important to develop technological tools that promote healthy eating. The immersive virtual reality application developed helps instruct children in the consequences of poor nutrition, promoting changing food tastes in a fun way. The results obtained through the application and the questionnaire indicate a positive influence on food preference.

## References

1. Velardo, S., Drummond, M.: Australian children's discourses of health, nutrition and fatness. *Appetite* **138**, 17–22 (2019). <https://doi.org/10.1016/j.appet.2019.03.014>
2. Ambroszkiewicz, J., Che, M., Szamotulska, K.: Bone status and adipokine levels in children on vegetarian and omnivorous diets. 1–8 (2018). <https://doi.org/10.1016/j.clnu.2018.03.010>
3. Castro, M.A.De, Verly-jr, E., Fisberg, M., Fisberg, R.M.: ienceDirect Children's nutrient intake variability is affected by age and body weight status according to results from a Brazilian multicenter study. *Nutr. Res.* **34**, 74–84 (2014). <https://doi.org/10.1016/j.nutres.2013.09.006>
4. Jílková, M., Kaupová, S., Alena, Č., Polá, L., Br, J., Velemínský, P.: Archives of oral biology early medieval diet in childhood and adulthood and its reflection in the dental health of a Central European population (Mikulčice, 9th – 10th centuries, Czech Republic) p. 107 (2019). <https://doi.org/10.1016/j.archoralbio.2019.104526>



5. Koutoukidis, D.A., Jebb, S.A.: Public health nutrition in the UK Key points. *Medicine (Baltimore)*, pp. 1–5 (2018). <https://doi.org/10.1016/j.mpmed.2018.12.006>
6. Luiza, J., et al.: *Complement. Ther. Clin. Pract.* (2019). <https://doi.org/10.1016/j.ctcp.2019.02.014>
7. Rathinam, C., Mohan, V., Peirson, J., Skinner, J., Nethaji, K.S., Kuhn, I.: Effectiveness of virtual reality in the treatment of hand function in children with cerebral palsy: a systematic review. *J. Hand Ther.* **32**, 426–434.e1 (2019). <https://doi.org/10.1016/j.jht.2018.01.006>
8. Watt, R.G., et al.: An exploratory randomised controlled trial of a public health nutrition intervention delivered in children’s centres in Islington and Cornwall. *Lancet* **382**, S100 (2010). [https://doi.org/10.1016/S0140-6736\(13\)62525-8](https://doi.org/10.1016/S0140-6736(13)62525-8)
9. Giap, H.B.: Can virtual reality, interactive game, and body motion sensors be a replacement for general anesthesia in children receiving radiation therapy? *Radiat. Oncol. Biol.* **102**, S149 (2018). <https://doi.org/10.1016/j.ijrobp.2018.06.361>
10. Tychsen, L., Foeller, P.: Effects of immersive virtual reality headset viewing on young children: visuomotor function, postural stability and motion sickness. *Am. J. Ophthalmol.* (2019). <https://doi.org/10.1016/j.ajo.2019.07.020>
11. Sigitov, A., Hinkenjann, A., Roth, T.: Towards VR-based systems for hool experiments. *Procedia - Procedia Comput. i.* **25**, 201–210 (2013). <https://doi.org/10.1016/j.procs.2013.11.025>
12. Bakr, A.F., Tarek, Z., Sayad, E., Makram, S., Thomas, S.: Virtual reality as a tool for children’s participation in kindergarten design process. *Alexandria Eng. J.* **57**, 3851–3861 (2018). <https://doi.org/10.1016/j.aej.2018.10.003>
13. Willis, R.E., Gomez, P.P., Ivatury, S.J., Mitra, H.S., Sickie, K.R.Van: Virtual reality simulators: valuable surgical skills trainers or video games? *J. Surg. Educ.* **71**, 426–433 (2014). <https://doi.org/10.1016/j.jsurg.2013.11.003>
14. Bailey, J.O., Bailenson, J.N., Obradovi, J., Aguiar, N.R.: Virtual reality’s effect on children’s inhibitory control, social compliance, and sharing. *J. Appl. Dev. Psychol.* **64** (2019). <https://doi.org/10.1016/j.appdev.2019.101052>
15. Brooke, J.: SUS-A quick and dirty usability scale. *Usability Eval. Ind.* **189**, 4–7 (1996)
16. Sauro, J.: Measuring usability with the system usability scale (SUS). *Meas. Usability.* (2011)
17. Finstad, K.: The usability metric for user experience. *Interact. Comput.* (2010). <https://doi.org/10.1016/j.intcom.2010.04.004>





## **VIII. Memory Diagnostic Application Using the FNAME**

### **Referencia:**

**Varela-Aldás, J.**, Buele, J., Pérez, D., & Palacios-Navarro, G. (2021). Memory Diagnostic Application Using the FNAME. *In International Conference on Information Technology & Systems* (pp. 41-50). Springer, Cham.



# Memory Diagnostic Application Using the FNAME

José Varela-Aldás<sup>1,3</sup> , Jorge Buele<sup>1</sup> , Doris Pérez<sup>2</sup> ,  
and Guillermo Palacios-Navarro<sup>3</sup> 

<sup>1</sup> SISAu Research Group, Facultad de Ingeniería y Tecnologías de la Información y la Comunicación, Universidad Tecnológica Indoamérica, Ambato, Ecuador

{josevarela, jorgebuele}@uti.edu.ec

<sup>2</sup> Facultad de Ciencias Humanas y de la Salud, Universidad Tecnológica Indoamérica, Ambato, Ecuador  
dorispez@uti.edu.ec

<sup>3</sup> Department of Electronic Engineering and Communications, University of Zaragoza, Zaragoza, Spain  
guillermo.palacios@unizar.es

**Abstract.** Memory loss is a problem that affects the majority of older adults worldwide. Making an early diagnosis allows specialist doctors to carry out rehabilitation programs as a preventive measure against cognitive problems. This has motivated the development of the present application for the diagnosis of memory, based on the already existing Face-Name Associative Memory Exam (FNAME). The test counts the number of correct answers when matching the face with the corresponding name, using the associative memory. In this way, a process that is previously carried out manually is automated, prioritizing having a more accurate measurement of the response times of the participants. In addition, a self-test is presented that allows having a second criterion on the user's diagnosis. Both tests are presented in an interactive interface that has been designed using MATLAB software, using the uicontrol tool. The experimental tests carried out corroborate the correct operation of this proposal, the results of which show scores and response times.

**Keywords:** Associative memory · Memory diagnosis · Early detection · Automated testing

## 1 Introduction

Memory is one of the most developed cognitive functions that humans have compared to animals [1, 2]. It is a basic element of the learning process, since it allows the person to store all kinds of information [3, 4]. Cognitive psychology and neuropsychology, as part of the study, have described different types of memory, among which stand out: the episodic, short and long term, semantic, procedural and associative [5]. These associations can be simple, like relating a known face to its respective name, but most of the time it is more complex and each memory is linked to many others. For this,

various brain regions are used: the visual cortex and occipital for access and image interpretation, frontotemporal regions for the organization and identification of features, the hippocampus to access memories related to the people patient see and the poles temporary to access the name [6].

Remembering a face is quite important in the social bond of the human being [7]. This process seems simple, since various faces are memorized throughout life, including several of the details. But the reality is that several factors intervene that enhance or reduce this capacity, for example, emotional aspects: remembering some faces more than others. There are also racial factors: the faces of individuals of the own race and geographic position are better recognized and remembered [8]. The memory of faces has been the subject of study by several researchers as can be seen in manuscripts [9] and [10]. These have studied the characteristics of face memory and its interaction with long and short-term memories, respectively.

In order to know the state of this cognitive capacity, it is important to use diagnostic tools to quantify its performance [11], with the help of technology it is possible to improve the characteristics of these tools [12–15]. In response to this, Rentz et al. designed in 2011 the Face-Name Associative Memory Test (FNAME) [16]. In some studies this intermodal associative memory test includes 16 face-name pairs and 16 face-occupation pairs, with a total of 32 pairs to remember [17]. Faces and names are presented and then asked to use the memory to recognize the pair (name-face). After its application, it is established whether the result is correct or incorrect, the number of hits and the reaction times for each execution.

This test has been applied as part of the treatment of various diseases. A work described in [18] evaluates the validity and reliability of the FNAME test in adults, to diagnose Parkinson's disease. The research carried out in [17] describes the studies that have explored the FNAME as a tool to establish the early diagnosis of Alzheimer's disease. This study highlights the Memory Capacity Test, FNAME Test and The Short-Term Memory Binding test. In addition to the original version, an adaptation to the Spanish language of the FNAME test has been made as presented in the works [19] and [20]. These investigations were applied to evaluate Alzheimer's patients from Colombia and Spain respectively. In [19] an adaptation has been made to 24 questions depending on the needs of the research, which is valid based on the need.

As has been presented in the bibliography, this diagnostic tool is commonly applied in older adults to define the percentage of the cognitive problems. In this work it is proposed to apply it to adults of different ages, as a preventive measure for the mental health and to have an early diagnosis. Usually, the test is done manually, presenting the images and names in presentations and the times are taken with a timer. This has motivated the present investigation and for this reason an interface has been developed in which this test can be applied in a more interactive way. The design is carried out in the MATLAB mathematical software and the tests are carried out on a personal computer. In addition to applying the FNAME test, a self-test is performed, which allows for more results; all this as part of an investigation of associative memory.

This document consists of 4 sections, where Sect. 1 is the introduction. Materials and methods are described in Sect. 2. The results of the experimental tests are presented in Sect. 3 and the conclusions in Sect. 4.

## 2 Materials and Methods

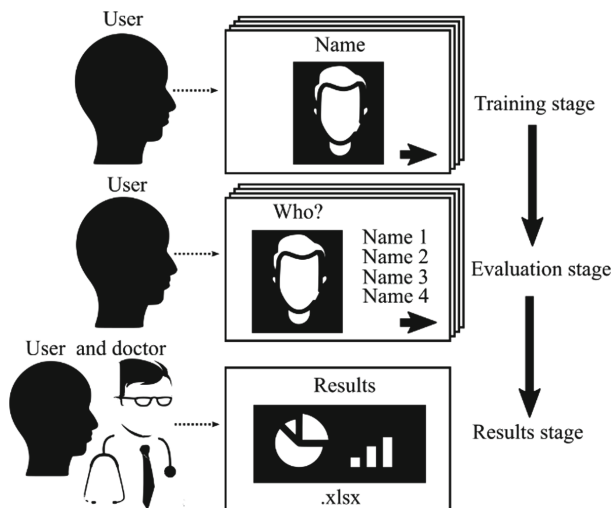
### 2.1 Application Design

The FNAME application has some variations in the characteristics and the number of questions, in its case it uses 30 pairs of names and faces. Generally, this test is applied using digital slides that are manually controlled by the evaluator, this makes it difficult to take the user response time accurately, and even affects the evaluation results. On the other hand, the development of applications for the diagnosis and treatment of neurodegenerative diseases is very common at present, these tools are important to agitate and improve medical processes, specifically to respond promptly to the disease. The objective of the application implemented in this work is to automate the FNAME test application, to this three stages have been designed as shown in Fig. 1.

*The training stage* - the user memorizes the faces and names presented on the screen, these data appear for a certain time and advance automatically until finishing the options.

*The evaluation stage* - the user must identify all the memorized faces, one at a time, relating the image to its respective name, choosing the correct name from four options presented on the screen.

*The results stage* - the results obtained are presented, this includes the score reached in the evaluation and the response times of the user. The results allow a medical diagnosis to be made and are saved in a file compatible with Excel, to generate a user history.



**Fig. 1.** Diagram of the stages that make up the application.

### 2.2 Programming

The application is developed in MATLAB. This is flexible software with useful tools to implement the requirements of this proposal. To generate user interfaces, the software has two ways of working, by means of an assistant (GUIDE) and using structured code (*uicontrol*), in its case it uses the *uicontrol* command that offers greater control of the elements in the user interface. Figure 2 shows the algorithm used for the proposed application initially the user enters the data, such as: name, age and whether or not she has a history related to memory problems. The data is then loaded for evaluation, reading the names and images of the faces from a database (*dataset* and *imread*). Proceeding with user training, presenting the 30 pairs sequentially, for each face-name 6 s are given to memorize the data (*imshow*). It continues with the evaluation, asking the user the names of each face presented in the training, in each question the user can take the time required and this value is continuously timed (*style: radioButton, tic-toc*). At the end of the test, the final score is generated in percentage of correct answers and all the data is saved in an XLSX file (*xlswrite*).

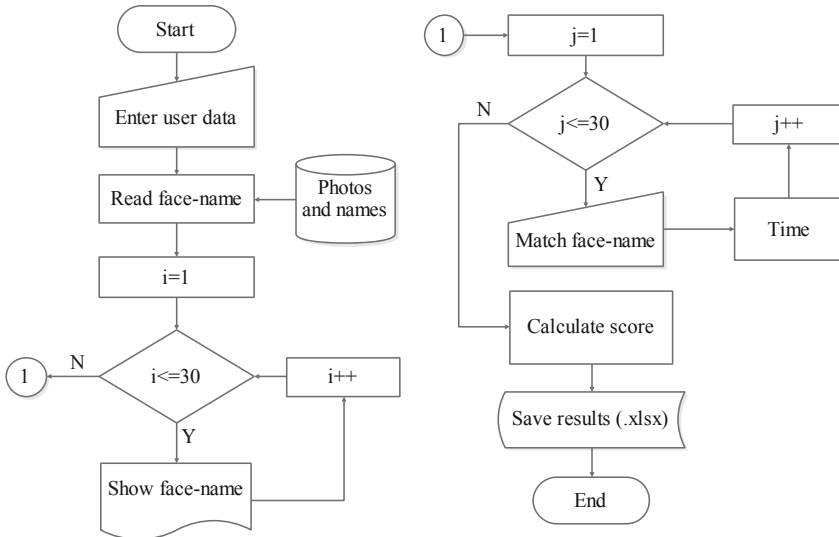


Fig. 2. Application flow chart.

### 2.3 Participants

To recruit volunteers, an open call to the public is carried out, obtaining a total of 33 registrants of different ages. As an exclusion criterion, the Mini-Mental State Examination MMSE test is applied, which allows detecting mental problems, discarding 3 participants who had a score lower than 26/30. The rest of the participants passed the exam and gave informed consent to carry out the experiments. In addition, all the ethical standards established in the regulations of the sponsoring University are followed.

This research is based on the quasi-experimental method, since it cannot have absolute control of all situations. Therefore, they are not using randomly chosen patients, but a previously constituted group. Techniques of this method are also used, such as questionnaires and standardized tests.

To test the application, participants of different ages have been selected and the characteristics are presented in Table 1. In total, there are 30 volunteers to evaluate the app, of these 17 are men and 13 are women, which describes that there is a higher percentage of males (57%). In relation to age, two groups are created: 6 participants aged 60 years and over and 24 volunteers under the age of 60; the average age of the entire group is 33 years, with a standard deviation (SD) of 10 years. Of all the participants, 77% did not have a history related to cognitive diseases or memory problems.

**Table 1.** Demographics of the participants.

Characteristic	Kind	Number	%	Mean	SD
Gender					
	Male	17	57%		
	Female	13	43%		
Age				33	10
	≥ 60	6	20%	61	1
	<60	24	80%	29	7
History					
	Yes	7	23%		
	No	23	77%		

In addition, participants complete a self-test, this exam contains 6 questions to quantitatively rate the perception of the state of the memory. These questions are obtained from an online test endorsed by Psychology Today [21]. Each question has 5 possible answer options valued as follows: 1- Almost never, 2- Rarely, 3- Sometimes, 4- Frequently and 5- Almost always. This exam is scored as a percentage according to the total score and with respect to the maximum possible score. The self-test is made up of the questions presented below:

1. Do you have difficulty in remembering phone numbers?
2. How often do you forget the location of everyday items?
3. How often do you have to replace passwords because you don't remember the original one?
4. How often do you forget what you were going to do next?
5. How often do you organize two or more plans for the same hour by forgetfulness?
6. How often do you have to ask someone to repeat what they said because you don't remember it?

### 3 Experimental Results

#### 3.1 Functional Testing

The tests with the participants are carried out individually and supervised by a technician to attend any problem. In all cases there are no difficulties in using the application and the participants expressed satisfaction in the development of the experiments. Figure 3 shows images of the application's user interface.

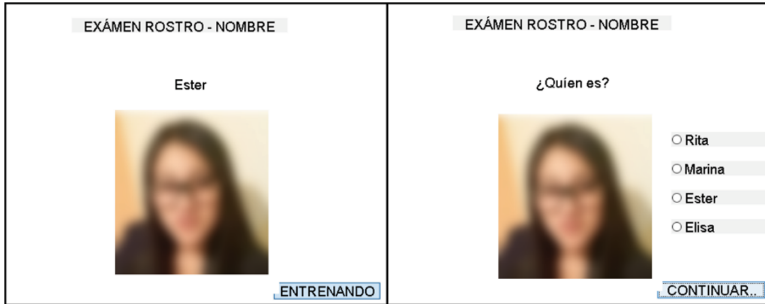


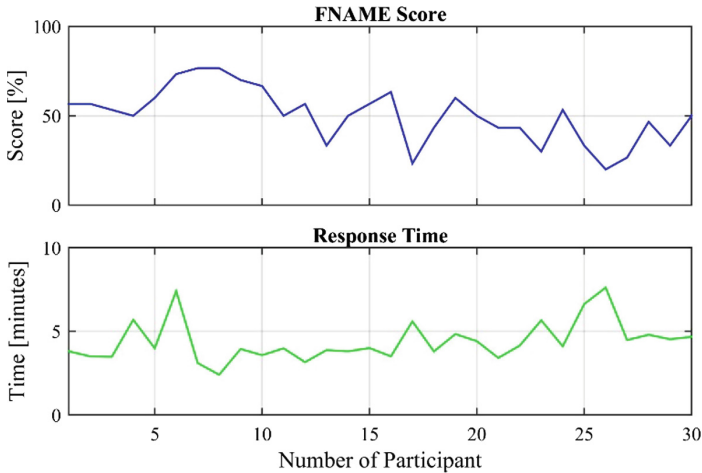
Fig. 3. Application of the FNAME test in operation.

#### 3.2 Application Results

Figure 4 presents the final results of the application used in the 30 participants. The scores obtained in the FNAME test and the evaluation times in each participant are observed, this information being valid for a quick diagnosis of the patient. In general, the scores are very diverse and the average is 50%, none exceeds 77% correct answers, and there are no scores less than 20%. On the other hand, the total response time has an average of 4.4 min, with a maximum time of 7.6 min and a minimum time of 2.4 min. In the correlation analysis between the FNAME score and time, there is a negative correlation of  $-0.47$ , which is not conclusive regarding the relationship between these variables, but there is some inverted influence of time with the score obtained.

In this way, the scores and response times of the participants are automatically obtained. The Face-name test is normally applied manually, this implies that the researcher must show the slides containing the training data one by one, trying to maintain an equitable time in each presentation. Furthermore, the only data acquired in the manual process are the scores obtained in the evaluation stage, and this informatics tool accurately provides the patient's response time for a more in-depth analysis of the cognitive state.

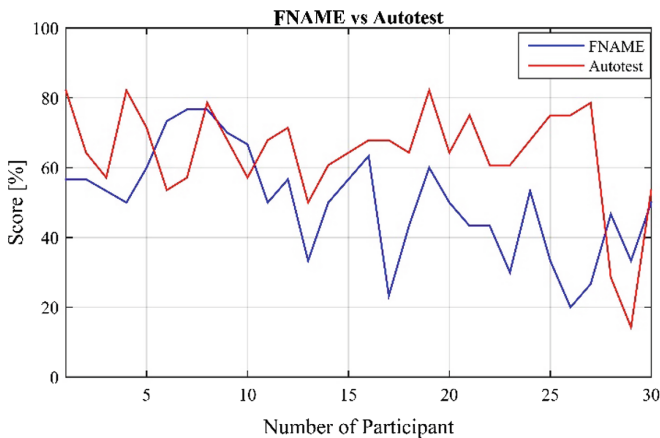




**Fig. 4.** Results of the scores and times obtained in the FNAME test.

### 3.3 Comparison with the Autotest

In the Autotest results, data apparently similar to the FNAME test results are obtained, as can be seen in Fig. 5. In the self-test there is an average of 64%, the maximum score is 82% and the minimum is 14%. The correlation results indicate a coefficient of 0.1, this value indicates a minimum positive correlation, which does not support a connection between the self-criteria of the participants and the results generated in the application.



**Fig. 5.** Results of the FNAME vs Autotest.

### 3.4 Discussion

Aging is a normal process in the life cycle of all living beings and that is why it is necessary to be able to evaluate certain cognitive functions that are gradually deteriorating. Both in [17] and [18] the use of FNAME is demonstrated as an early diagnostic tool for the treatment of Alzheimer's disease in older adults. This context is important because it strengthens the purpose of this research and also allows a contrast to be made when using participants who are young and older adults, obtaining different results. With respect to the works [19] and [20] they represent a basis for this document, since they allow to corroborate the use of this test for Spanish-speaking people. Although each proposal has different parameters of evaluation and tabulation of results, it can be seen that the results vary according to the population being studied (Colombia, Spain) and Ecuador in this research.

## 4 Conclusions

Memory in a higher mental process that in the light of cognitivism has made it possible to understand that it is not a unitary and independent function but that it presents several types of memory whose terminology may vary according to some researchers, its functionality is given by the interaction of multiple neural networks that link areas of the cortex and subcortex, being complex their study and diagnosis through various tests proposed over time, the development of technology can offer better opportunities for their study.

The FNAME test is a widely used tool in the diagnosis of neurodegenerative diseases in prone or elderly patients, as shown in the literature. This document presents a computer application to apply the FNAME test, automating the training process, evaluation and generation of results. The application is implemented in MATLAB software and is applied to 30 participants of different ages. The results show total scores and time of each test performed, obtaining parameters for early diagnosis and prevention of cognitive problems related to memory. Besides, a self-test is applied that generates results that are not consistent with the application's results, evidencing the need for this application to contrast with the patient's own perception of his memory capacity. Although conducting a quasi-experimental investigation could skew the results obtained, performance tests have shown that this proposal is practical and can be applied to users.

As it is done in this application, other conventional procedures can be automated, using technology in the field of medicine and psychology. As part of this research, the aim is to use this application and compare it with new methods of diagnosis and treatment, involving new tools such as virtual and augmented reality and analyzing its effects on the participants.

## References

1. Majerus, S.: Working memory treatment in aphasia: a theoretical and quantitative review. *J. Neurolinguistics* **48**, 157–175 (2018). <https://doi.org/10.1016/j.jneuroling.2017.12.001>
2. Loprinzi, P.D., Blough, J., Crawford, L., Ryu, S., Zou, L., Li, H.: The temporal effects of acute exercise on episodic memory function: systematic review with meta-analysis. *Brain Sci.* **9**, 87 (2019). <https://doi.org/10.3390/brainsci9040087>
3. Greene, N.R., Naveh-Benjamin, M.: A specificity principle of memory: evidence from aging and associative memory. *Psychol. Sci.* **31**, 316–331 (2020). <https://doi.org/10.1177/0956797620901760>
4. Loprinzi, P.D., Blough, J., Ryu, S., Kang, M.: Experimental effects of exercise on memory function among mild cognitive impairment: systematic review and meta-analysis. *Phys. Sportsmed.* **47**, 21–26 (2019). <https://doi.org/10.1080/00913847.2018.1527647>
5. Schutz, M., Stefanucci, J.K., Baum, S.H., Roth, A.: Name that percussive tune: associative memory and amplitude envelope. *Q. J. Exp. Psychol.* **70**, 1323–1343 (2017). <https://doi.org/10.1080/17470218.2016.1182562>
6. Brunyé, T.T., Moran, J.M., Holmes, A., Mahoney, C.R., Taylor, H.A.: Non-invasive brain stimulation targeting the right fusiform gyrus selectively increases working memory for faces. *Brain Cogn.* **113**, 32–39 (2017). <https://doi.org/10.1016/j.bandc.2017.01.006>
7. Peterson, D.J., Schmidt, N.E., Naveh-Benjamin, M.: The role of schematic support in age-related associative deficits in short-term and long-term memory. *J. Mem. Lang.* **92**, 79–97 (2017). <https://doi.org/10.1016/j.jml.2016.05.007>
8. Ramon, M., Gobbin, M.I.: Familiarity matters: a review on prioritized processing of personally familiar faces. *Vis. cogn.* **26**, 179–195 (2018). <https://doi.org/10.1080/13506285.2017.1405134>
9. Rugo, K.F., Tamler, K.N., Woodman, G.F., Maxcey, A.M.: Recognition-induced forgetting of faces in visual long-term memory. *Atten. Percept. Psychophys.* **79**, 1878–1885 (2017). <https://doi.org/10.3758/s13414-017-1419-1>
10. Gignac, G.E., Shankaralingam, M., Walker, K., Kilpatrick, P.: Short-term memory for faces relates to general intelligence moderately. *Intelligence* **57**, 96–104 (2016). <https://doi.org/10.1016/j.intell.2016.05.001>
11. Weeks, J.C., Biss, R.K., Murphy, K.J., Hasher, L.: Face–name learning in older adults: a benefit of hyper-binding. *Psychon. Bull. Rev.* **23**, 1559–1565 (2016). <https://doi.org/10.3758/s13423-016-1003-z>
12. García-Magariño, I., Varela-Aldas, J., Palacios-Navarro, G., Lloret, J.: Fog computing for assisting and tracking elder patients with neurodegenerative diseases. *Peer-to-Peer Netw. Appl.* **12**, 1225–1235 (2019)
13. Chicaiza, F.A., Lema-Cerda, L., Álvarez, V.M., Andaluz, V.H., Varela-Aldás, J., Palacios-Navarro, G., García-Magariño, I.: Virtual reality-based memory assistant for the elderly. In: *Lecture Notes in Computer Science*, pp. 269–284 (2018)
14. Varela-aldás, J., Palacios-Navarro, G., García-Magariño, I.: Immersive virtual reality app for mild cognitive impairment. *Rev. Ibérica Sist. e Tecnol. Informação RISTI.* **04**, 278–290 (2019)
15. González-Landero, F., García-Magariño, I., Amariglio, R., Lacuesta, R.: Smart cupboard for assessing memory in home environment. *Sensors (Switzerland)* **19**, 1–21 (2019). <https://doi.org/10.3390/s19112552>
16. Rentz, D.M., Amariglio, R.E., Becker, J.A., Frey, M., Olson, L.E., Frishe, K., Carmasin, J., Maye, J.E., Johnson, K.A., Sperling, R.A.: Face-name associative memory performance is related to amyloid burden in normal elderly. *Neuropsychologia* **49**, 2776–2783 (2011). <https://doi.org/10.1016/j.neuropsychologia.2011.06.006>

17. Rubiño, J., Andrés, P.: The face-name associative memory test as a tool for early diagnosis of Alzheimer's disease. *Front. Psychol.* **9**, 1464 (2018). <https://doi.org/10.3389/fpsyg.2018.01464>
18. Kormas, C., Zalonis, I., Evdokimidis, I., Potagas, C.: The performance of patients with Parkinson's disease on the face-name associative memory examination. *Neurol. Sci.* **40**, 405–407 (2019). <https://doi.org/10.1007/s10072-018-3560-6>
19. Vila-Castelar, C., Papp, K.V., Amariglio, R.E., Torres, V.L., Baena, A., Gomez, D., Rendon, J., Samaroo, A., Lopera, F., Rentz, D.M., Quiroz, Y.T.: Validation of the Latin American Spanish version of the face-name associative memory exam in a Colombian Sample. *Clin. Neuropsychol.* (2019). <https://doi.org/10.1080/13854046.2019.1690050>
20. Sanabria, A., Alegret, M., Rodríguez-Gomez, O., Valero, S., Sotolongo-Grau, O., Monté-Rubio, G., Abdelnour, C., Espinosa, A., Ortega, G., Perez-Cordon, A., Gailhajanet, A., Hernandez, I., Rosende-Roca, M., Vargas, L., Mauleon, A., Sanchez, D., Martin, E., Rentz, D.M., Lomeña, F., Ruiz, A., Tarraga, L., Boada, M., Aguilera, N., Berthier, M., Buendia, M., Bullich, S., Campos, F., Cañabate, P., Cuevas, C., De Rojas, I., Diego, S., Gil, S., Giménez, J., Gismondi, R., Gómez-Chiari, M., Guitart, M., Hernández-Olasagarre, B., Ibarria, M., Lafuente, A., Martínez, J., Moreno, M., Moreno-Grau, S., Núñez, L., Orellana, A., Páez, A., Pancho, A., Pavía, J., Pelejà, E., Pérez-Grijalba, V., Pesini, P., Preckler, S., Romero, J., Ruiz, S., Santos, M., Sarasa, M., Tejero, M.A., Torres, M., Vivas, A.: The Spanish version of face-name associative memory exam (S-FNAME) performance is related to amyloid burden in subjective cognitive decline. *Sci. Rep.* **8**, 1–9 (2018). <https://doi.org/10.1038/s41598-018-21644-y>
21. Psychology Today: Memory test. <https://psychologytoday.tests.psychtests.com/bin/transfer?req=MTF8MzM2MHw2NzI5MDI0fDB8MQ>