

Water Resources Research®

RESEARCH ARTICLE

10.1029/2024WR038514

Probabilistic Trade-Offs Analysis for Sustainable and Equitable Management of Climate-Induced Water Risks



Key Points:

- The spatio-temporal change in the trade-offs between competing water uses is assessed using a stochastic dynamic hydro-economic model
- Sector-priority water allocation policies could not ensure an equitable benefit sharing among all sectors under future climate uncertainty
- Outcomes of sector-priority water allocation policies define the upper and lower bounds of the negotiation space among water use sectors

Supporting Information:

Supporting Information may be found in the online version of this article.

Correspondence to:





J. Albiac,
maella@unizar.es

Citation:

Baccour, S., Tilmant, A., Albiac, J., Espanmanesh, V., & Kahil, T. (2025). Probabilistic trade-offs analysis for sustainable and equitable management of climate-induced water risks. *Water Resources Research*, 61, e2024WR038514. <https://doi.org/10.1029/2024WR038514>

Received 25 JUL 2024

Accepted 8 JAN 2025

S. Baccour^{1,2} , A. Tilmant³ , J. Albiac^{2,4} , V. Espanmanesh³, and T. Kahil² 

¹Research Institute of Water Engineering and Environment (IIAMA), Universitat Politècnica de València, Valencia, Spain, ²Water Security Research Group, Biodiversity and Natural Resources Program, International Institute for Applied Systems Analysis (IIASA), Laxenburg, Austria, ³Department of Civil Engineering and Water Engineering, University of Laval, Quebec City, QC, Canada, ⁴Department of Economic Analysis, University of Zaragoza, Zaragoza, Spain

Abstract Pressures on water resources are fueling conflicts between sectors. This trend will likely worsen under future climate-induced water stress, jeopardizing food, energy and human water security in most arid and semi-arid regions. Probabilistic analysis using stochastic optimization modeling can characterize multi-sector vulnerabilities and risks associated with future water stress. This study identifies the probabilistic trade-offs between agricultural, urban and energy sectors in the Ebro Basin (Spain). Two intervention policies have been examined and compared: (a) agricultural priority, and (b) energy priority, for two planning horizons 2040–2070 and 2070–2100. Results show that the human water security goal is achieved under both intervention policies. However, the achievement of the food and energy security goals depends on the policy objectives and on the spatial location of irrigation schemes and hydropower plants, which result in different stream flows across the basin. The policy choice results in substantially different benefit gains and losses by sector and therefore by location. None of the sectoral production priority policy provides an equitable sharing of benefits among all sectors and locations under climate change, which is an important issue, because the success or failure of policy interventions would depend on the distribution of the gains and losses of benefits across the basin. Policy uptake by stakeholders would depend on reaching win-win outcomes where losers are compensated, while delivering acceptable levels of food, energy and human water security in large river basins. Information on the probabilistic trade-offs contributes to the design of water management strategies capable of addressing the multi-sector vulnerability.

1. Introduction

Water resources are essential for food, energy and human water security (Cheng et al., 2019). The sharp rise of water withdrawals during the last century has created massive pressures on water resources and led to severe environmental degradation and major management challenges in many river basins worldwide (Greve et al., 2018). These challenges are expected to become more critical in the coming decades, driven by imminent socioeconomic and climate changes. In the period 1980–2010, drought damages and economic losses in Europe are estimated at € 9 billion per year, mostly affecting Spain (1.5 b.), Italy (1.4 b.) and France (1.2 b.), with damages concentrating in the agriculture (50%) and energy (35%) sectors. These estimates capture the overall economic losses recorded in each country for each drought event across multiple sectors (agriculture, urban water supply and energy sectors), but excluding impacts on ecosystems. Future damages could increase up to five times for a +3°C scenario (Cammalleri et al., 2020; Feyen et al., 2020). Management policies in arid and vulnerable river basins must thus be adapted to address the future water challenges. The development of adaptation policies including water allocation requires the analysis of trade-offs across sectors, such as urban water supply, agricultural production, energy generation, and ecosystem health, as well as across space and time (Cai et al., 2018). A critical policy task is to understand and identify the tradeoffs between competing uses, by finding the gains and losses for alternative water allocation policies under climate change. Then, the scope of policymaking negotiation can go beyond outdated water allocation rules, and seek efficient, equitable and sustainable policies (Tilmant et al., 2020).

Addressing future climate vulnerability in water sectors is a growing topic that is critical for drought risk research and for the design and implementation of adaptation strategies (Vargas & Paneque, 2017). Vulnerabilities in water resources are defined as the degree to which a system, subsystem, or system component is likely to experience harm due to exposure to a hazard, either a perturbation or stress/stressor (Turner et al., 2003). Zhang

© 2025. The Author(s).

This is an open access article under the terms of the [Creative Commons Attribution License](https://creativecommons.org/licenses/by/4.0/), which permits use, distribution and reproduction in any medium, provided the original work is properly cited.

et al. (2023) emphasize the need to assess water resources vulnerability and identify spatio-temporal patterns for policymaking. The rising interest in vulnerability assessment is predominantly driven by climate change, and more particularly how to exploit climate information to inform and enhance decision-making processes. This research develops a bottom-up approach based on stress tests in order to identify conditions under which water systems require adaptation policies (Brown et al., 2012). The bottom-up approach emphasizes an in-depth examination of context-specific data. It involves local stakeholders in assessing and developing a shared vision of the system's vulnerability and performance and defining critical thresholds to identify system failure. This approach enables a more nuanced assessment of climate change impacts and priority policies and engages stakeholders in climate-related decision-making (Kuang & Liao, 2020; Poff et al., 2016). In contrast, the top-down approach evaluates the performance of water resource systems based on a set of global climate projections, typically downscaled to represent local conditions, making it unsuitable for identifying thresholds of performance with respect to changes in climate exposure (Sant'Anna et al., 2022). In our study, the bottom-up approach depends on a locally relevant integrated hydro-economic model to characterize and assess the system performance with regard to future climate projections.

Water system models can be used to identify trade-offs in complex water resource systems, involving multiple and interdependent water uses. More specifically, optimization modeling is an efficient tool for optimal water allocation and for identifying trade-offs between sectors and spatial locations (Wu et al., 2022). Our literature review reveals that only a limited number of solutions available can handle system and hydrologic complexities. One of them is the Direct Policy Search (DPS), initially proposed by Rosenstein and Barto (2001) and commonly known in the water resources literature as parameterization-simulation-optimization by Koutsyiannis and Economou (2003). This approach is used in reinforcement learning (Busoni et al., 2011) and control systems, where the objective is to maximize specified performance measures by directly exploring policy parameters. The policy is represented with adjustable parameters and iterative refinement by optimization techniques such as gradient-based methods (Peters & Schaal, 2008; Sehnke et al., 2010) or evolutionary algorithms (Busoni et al., 2011; Whiteson & Stone, 2006; Whitley et al., 1993). The DPS allows broadening the number and complexity of objectives that can be resolved (Giuliani et al., 2014; Libisch-Lehner et al., 2019), addressing reservoirs operation in complex multi-objective contexts (Giuliani et al., 2021), and exploring multisectoral trade-offs (Giuliani & Castelletti, 2016; Quinn et al., 2017). However, as pointed out by Castelletti et al. (2013), those simulation-based optimization methods may become computationally demanding when the number of objectives increases, and difficult to parametrize when the water resources system is large and its network is complex. Another challenge is that it overfits the policy parameters to the specific stochastic realizations encountered during simulation-based optimization, potentially leading to impressive calibration results that degrade considerably when tested on out-of-sample observations (Brodeur et al., 2020). Nonlinear optimization models offer another alternative, capable of representing complex interactions and interdependencies between different sectors and providing a more realistic representation of real-world systems. However, these models often require extensive and high-quality data to accurately parameterize complex relationships. Several nonlinear optimization models have been applied to identify the interaction between sectors and to inform policy debates (Baccour et al., 2021, 2024; Cai et al., 2018; Crespo et al., 2019; Jalilov et al., 2016, 2018). Stochastic Dual Dynamic Programming (SDDP) presents yet another approach (Pereira & Pinto, 1991) relying on iterative procedure to approximate the benefit-to-go function through sampling and Benders' decomposition (Pereira & Pinto, 1983). The benefit-to-go function represents the aggregated future benefit over the state-space domain. In SDDP, it is iteratively constructed as the model progresses through forward simulation and backward optimization passes, refining the estimation of future benefits at each stage (Goor et al., 2011; Tilmant & Kelman, 2007). The procedure evaluates the long-term value of actions, enabling algorithms to identify optimal policies that maximize total rewards, crucial for multi-stage decision-making. The SDDP has been successfully employed to solve optimization problems with stochastic inflows. Several studies used the SDDP to assess the economic value of coordination in a multi-user and multi-reservoir system, to determine the costs and benefits related to the multi-reservoir operation (Goor et al., 2010; Marques & Tilmant, 2013).

The study addresses the complex challenge of managing water resources in large river basins under climate variability. One of the critical issues in water management is the competition for limited water resources among various sectors and spatial locations, particularly with increasing water withdrawals over the past century, which have placed considerable pressure on water resources. Besides, sectoral vulnerabilities lead to substantial

economic losses during droughts. This study contributes to a growing body of work on handling the complex interactions and interdependencies among sectors (agriculture, energy, urban), agricultural intra-sectors (field crops, vegetables, and fruit trees), and spatial locations (upstream, downstream), offering insights into the geographic distribution of water demands and vulnerabilities, and pinpointing which areas are most at risk under future climate scenarios. This helps prioritize areas in the basin for policy intervention and resource allocation. It also discovers coalitions of objectives, revealing how different sectors can cooperate or conflict, determining the extent of gain and losses of benefits and aiding in the development of more integrated and cohesive water management strategies.

The Stochastic Dual Dynamic Programming (SDDP) is an optimization method designed for solving multistage stochastic decision-making problems. It was first proposed by Pereira and Pinto (1991) to solve the hydro-thermal scheduling problem in Brazil. Like any Dynamic Programming algorithm, SDDP converts the original sequential decision-making problem into a sequence of one-stage problems that are solved recursively (Sant'Anna et al., 2022). In this study, we extend the application of the SDDP approach beyond its traditional use for the operation of single or few reservoirs, in order to assess the probabilistic trade-offs between multiple sectors and agricultural intra-sectors across their spatial locations in a large river basin spanning multiple jurisdictions under future climate conditions. The probabilistic trade-off is an approach used to understand the relationship between objective values and their associated reliability, which is quantified through probability distributions (Smith et al., 2013). The probabilistic trade-off analysis helps identify the best allocation strategy, considering both potential future benefits and risks. While previous work, such as Tilmant et al. (2020), explored the trade-offs in sectors like agriculture, floodplain, hydropower, navigation, and fisheries within the Senegal River basin in a simplified manner (27 nodes, 5 reservoirs, 6 hydropower plants and 10 irrigation districts), this research introduces a comprehensive assessment of how these sectors interact spatially in a complex large-scale river basins under varying climate scenarios, and focus on the economics of water use including detailed crop representation. The analysis emphasizes the economics of water use by sectors, with a detailed representation of crop cultivation. Our monthly and dynamic hydroeconomic model includes 52 water supply and demand nodes, 13 reservoirs, 16 hydropower plants, 8 urban centers, and 12 irrigation districts growing 27 crops under different irrigation technologies (flood, sprinkler, drip). This detailed basin's representation, along with the explicit inclusion of crops and spatial locations in the assessment is a crucial advancement as it addresses a gap in understanding the sectoral and intra-sectoral dynamics and interactions in each spatial location in the basin under increasing water stress and climate pressures. This is relevant for Spain, where this study is the first application of SDDP to analyze probabilistic trade-offs, highlight sectoral vulnerabilities and assess economic losses associated with water use under climate uncertainty. The approach taken in this paper not only improves the assessment methods of water system vulnerabilities, but also supports the development of more robust and adaptive strategies for managing water resources in large, stressed river basins.

To illustrate these concepts, the Ebro River basin in northeast Spain serves as a key case study. This Mediterranean basin faces significant challenges, including seasonal water scarcity, competing demands from agriculture, hydropower, and domestic uses, where the growing impacts of climate change will intensify water stress and variability. The study enables a nuanced examination of how different water allocation policies affect each sector under baseline and future climate conditions. This approach addresses the basin's challenges by revealing probabilistic trade-offs, identifying vulnerable objectives, and enhancing cross-sectoral planning. An objective is vulnerable when its performance gets "significantly" degraded for a given change affecting one external stressor. The extent to which objectives are affected by a stressor is not necessarily the same; the relative performance of the different objectives is most of the time not identical once the water resource system is under stress. For instance, the hydro-economic model optimizes the distribution of the stress so that the basin-wide net benefits are maximized, but some objectives could lose more than others.

To characterize those elements, we first find out the optimal water allocation that may be adopted to share water resources in an increasingly complex system in the baseline scenario. Then, priority policies are used in simulation and the economic and hydrologic effects are evaluated in each sector's spatial location for the baseline and future climate conditions. From this assessment, probabilistic trade-offs are revealed, coalitions of objectives are discovered, and vulnerable objectives are identified for user groups. A coalition of objectives occurs when the corresponding desired policies are fully aligned; that is, when the corresponding policies are not conflicting. A well-known example is hydropower generation and navigation: hydropower generation tends to augment low flows, which in turn supports river shipping. In addition, probabilistic trade-offs could inform a nexus dialog

between the different sectors and their spatial distribution, improving cross-sectoral planning and achieving equitable trade-offs. Equitable trade-offs seek to balance the benefits and vulnerabilities of different sectors and spatial locations in the resource allocations decisions. For instance, under limited water availability, equitable trade-offs could involve prioritizing urban water use while balancing agricultural and hydropower needs through adaptive policies.

This paper addresses the water challenges and sectoral vulnerabilities under future climate uncertainty and water stress by providing information on the hydrologic and economic risks associated with different water allocation policies. The spatial distribution of benefit gains and losses from water stress scenarios are important aspects in the debate on sustainable basin management, which requires stakeholder participation and equitable benefit sharing in strategic planning (Wilson, 2019). More specifically, the analysis helps characterize crucial elements that ensure greater equity (fairness in allocation planning) when designing water and benefit-sharing arrangements (Grey & Sadoff, 2007): Who wins (loses) and where? How sensitive are those losses to natural stressors? Equity is critical when considering the unequal distribution of reducing water resources and increasing water demand impacts (Valipour et al., 2024). As indicated by Dinar et al. (2015), benefit-sharing arrangements are relevant for ensuring resilient and adaptive communities.

This paper is organized as follows: Section 2 starts with a presentation of the Ebro River basin, which is followed by a description of the development of the model and management scenarios and policies. Section 3 provides the hydrologic and economic impacts of climate risks with a focus on the trade-offs and economic losses. Section 4 discusses the simulation results and policy implications. Finally, concluding remarks are given in Section 5.

2. Materials and Methods

2.1. Case Study: The Ebro River Basin

The Ebro River Basin is one of the main European Mediterranean basins located in the north-east of the Iberian Peninsula. The Ebro is the longest river in Spain (930 km), covering 85,600 km² and being home to 3.2 million inhabitants (Figure 1). Renewable water resources amount to 15,500 million cubic meters (Mm³) per year, with 8,830 Mm³ of water withdrawals of which 8,140 for irrigation, 480 for urban networks and 210 for direct industry abstractions. The use of groundwater is limited (5% of withdrawals) so there are few local aquifer exploitation problems, which only affect the Gallocanta, Campo de Cariñena or Alfamén aquifers, with no large-scale impact on the Ebro River. An intense development of water infrastructures took place during the twentieth century due to the large expansion of irrigation and a surge in economic development and industrialization. The consequence has been the growing pressure on water resources and the ensuing problems of water scarcity that have been aggravated by periodic droughts, especially in the middle basin.

In the Ebro basin, there are 353 hydroelectric plants in service (4,229.45 MW of installed power), but the 15 most productive usually account for around 50% of the hydroelectric production of the entire basin annually. The average annual hydroelectric production in the last 13 years (2006–2018), stands at 8,029 GWh. This hydroelectric production is characterized by its great variability related to hydrological regimes. In dry years, hydropower production could decrease well below the average (5,950 GWh in 2017), while in wet years hydropower production could increase substantially, close to 10,616 GWh in 2016 (CHE, 2022b). The hydroelectric capacity in the Ebro basin is concentrated in the subbasins on the left bank, mainly in the Cinca-Segre rivers (Cinca, Ésera, Nogueras, Segre; nodes 36, 39, 41, and 43 in Figure 2) and in the lower Ebro reservoir system: Mequinenza, Ribarroja, and Flix (nodes 32, 33, and 48 in Figure 2), which are the most productive plants in the basin.

Water resources in the Ebro are managed by the Ebro water authority (Confederación Hidrográfica del Ebro). A special characteristic of the water authority is the crucial role played by user groups, which maintains the traditional culture of stakeholders' cooperation. Users from every sector (irrigation, urban, industrial and hydropower), central and state governments, municipalities, farmers' unions, environmental associations, business associations and workers unions are represented in the water authority taking and enforcing decisions.

The pressures on water resources in the Ebro Basin are going to be aggravated by the impacts of climate change with reductions and increased variability of water availability (CHE, 2022a). As indicated, severe droughts occur about every 10 years in recent decades. The resulting damage costs for economic sectors in the Ebro basin are considerable, reaching 400 million euros in 2005 (0.5% of GDP) (Hernández et al., 2013; Lines et al., 2017),

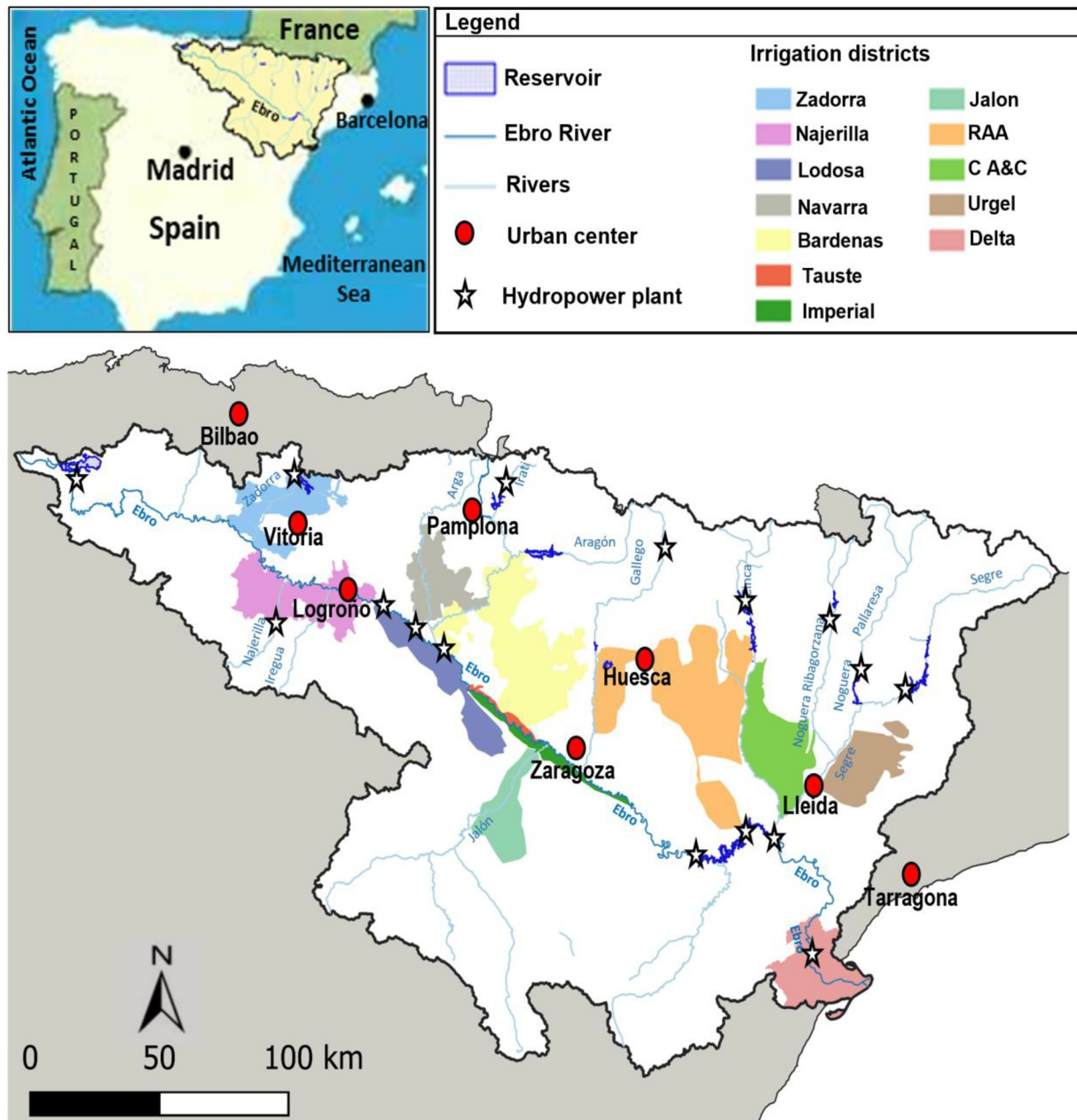

Figure 1. The Ebro River basin in Spain.

although the average yearly drought damages could be estimated at below 0.1% of GDP (Feyen et al., 2020). The damage costs originate mainly from agriculture (60%), followed by energy (30%) and domestic sectors (10%).

Interactions between climate and land use drivers, water availability and water withdrawals have led to an increased level of conflicts among the Ebro basin sectors and locations, including farmers, cities, industries, environmental flow protection, as well as between the federal water authority, states in the basin, and local administrations (Crespo et al., 2019). The effects of water scarcity and droughts portend unprecedented levels of water resources degradation in the absence of remediating water reforms. The worsening of future extreme hydroclimatic events further threatens sustainable outcomes, and calls for a reconsideration of the current water management, institutions and policies not only in the Ebro but also in all Mediterranean basins.

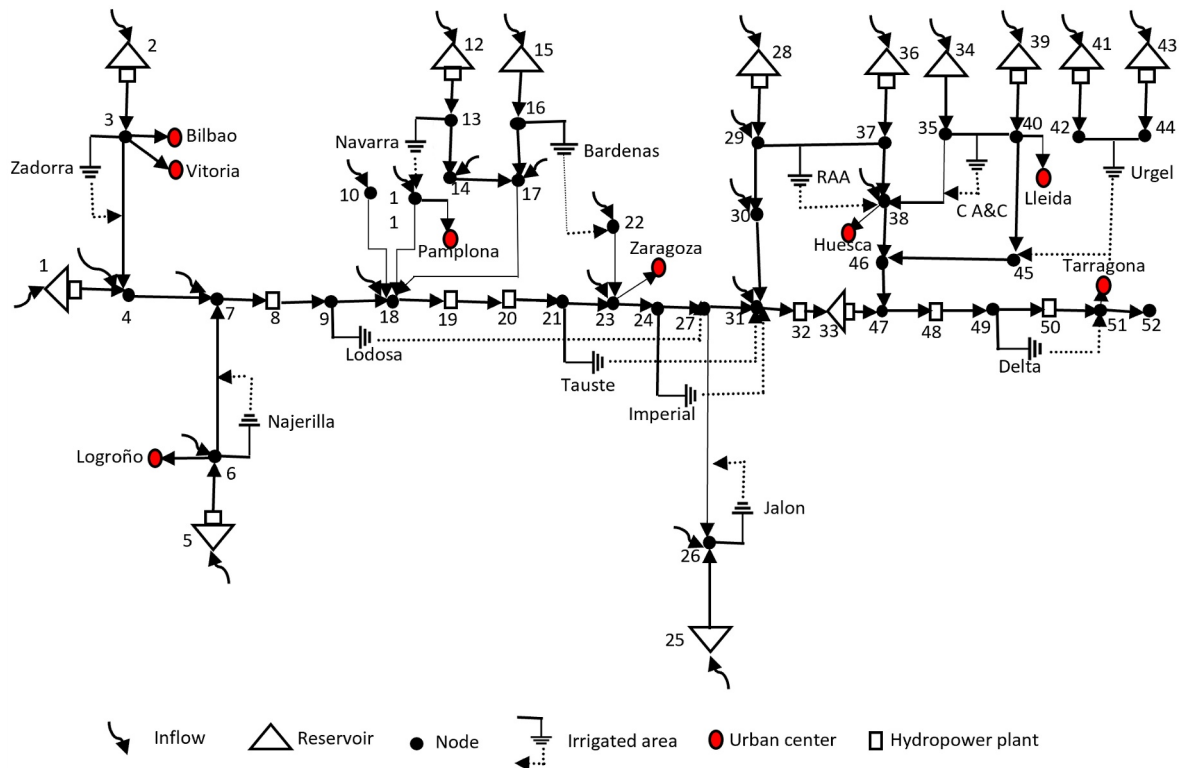

Figure 2. Schematic representation of the Ebro River basin (Reservoir and tributary names are presented in Table S10 of Supporting Information S1).

2.2. The SDDP Model for Economically Optimal Allocation

A stochastic hydro-economic model of the Ebro basin is developed in order to assess cross-sectoral probabilistic trade-offs, and hydrological and economic risks under climate change. The model is solved with the SDDP algorithm that could deal with complex multi-stage and stochastic problems, applying the Bellman's principle of optimality (Bellman, 1957). The SDDP model is coded in MATLAB and relies on the Gurobi linear programming solver. The model integrates the economic activities and the hydrologic system, and it is used to analyze different policies of water allocation among water sectors. Figure 2 shows the schematic representation of the Ebro basin, which includes 52 nodes, 13 reservoirs, 16 hydropower plants, 8 urban centers, and 12 irrigation districts growing 27 crops under different irrigation technologies (flood, sprinkler, drip) (see Table S10 in Supporting Information S1). The optimal allocation decision is determined at monthly time steps over a period of 30 years. The Ebro basin authority and CEDEX (CEDEX, 2016; CHE, 2016) provide monthly data on streamflow and reservoir storage for the entire 30 year period (1986–2016). Several sources of data on crop yields, prices, production costs, water requirements and land in production were secured from the Spanish Ministry of Agriculture and State Governments (DGA, 2016; GC, 2016; GN, 2016; MAPAMA, 2021).

The multistage decision-making problem of a multi-reservoir system is to determine a sequence of allocation decisions x_t that maximize the expected net benefit from system operation over a given planning period T while meeting hydrological and institutional constraints. The objective function of the optimization problem is written as follows:

$$Z^* = \max_{x_t} \left\{ \mathbb{E}_{q_t} \left[\sum_t^T \alpha_t \cdot b_t(S_t, x_t) + \alpha_{T+1} \cdot v(S_{T+1}) \right] \right\} \quad (1)$$

where $\mathbb{E}[\cdot]$ is the expectation operator and Z^* is the total benefit associated with the optimal solutions $(x_1^*, x_2^*, \dots, x_T^*)$. x_t represents the vector of allocation (decision) variables, q_t is the vector of stochastic inflows, S_t represents the vector of state variables that is described by the volume of storage s_t . $v(\cdot)$ is the terminal value

function, α_t is the discount factor at stage t . $b_t(\cdot)$ is the one-stage net benefits function at stage t (one-stage represents a single time period, with each time period set as a monthly timestep across a 30-year planning horizon).

Equation 2 is the sum of the net benefits from irrigated agriculture, hydropower, and urban settlements for the upstream and downstream areas of the Ebro River basin minus penalties for not meeting target water demands.

$$b_t(\cdot) = \text{HP}_t + \text{IR}_t + \text{UR}_t - \xi_t^T z_t \quad (2)$$

where HP_t is the benefits from hydropower production, IR_t is the benefits from irrigation, UR_t is the benefits from urban water use, z_t is the vector of slack variables and ξ_t^T is the vector of penalties (€/unit of deficit or surplus).

The net benefits from hydropower generation at stage t is the sum of energy production for each hydropower plant h and is estimated as follows:

$$\text{HP}_t = \sum_h \tau_t \cdot \widehat{P}_t^T \cdot (\pi_t - \theta_t) \quad (3)$$

where τ_t is the number of hours in period t , π^h is the short-run marginal cost (SRMC) of the hydropower production [€/MWh], θ^h is the operational and maintenance costs of the different hydropower plants [€/MWh], and \widehat{P}_t is the vector of approximated hydropower generated during period t and is determined based on the convex hull approximation (please see the explanation below).

SRMC is the short-run marginal cost of the hydrothermal electrical system to which the hydropower plants are connected. It is the variable cost of the hydropower plant at the margin, that is, the last power plant called by the system operator in order to meet the electricity demand in the system.

The net benefit from irrigated agriculture IR_t is the sum of the benefits $\zeta_{t_f}^{(p,d,k)}$ obtained for each crop p and irrigation technology k at each irrigation demand site d at the harvest stage t_f of the irrigation season. The benefits from irrigated agriculture are calculated by:

$$\text{IR}_t = \begin{cases} \sum_d \sum_k \sum_p \zeta_{t_f}^{(p,d,k)} & \text{if } t = t_f \\ 0 & \text{if } t \neq t_f \end{cases} \quad (4)$$

The net benefit function $\zeta_{t_f}^{(p,d,k)}$ associated with crop p , irrigation technology k at site d is given by:

$$\zeta_{t_f}^{(p,d,k)} = [\pi^{(p,d,k)} \cdot c^{(p,d,k)} - \theta^{(p,d,k)}] \cdot A^{(p,d,k)} \quad (5)$$

where $\pi^{(p,d,k)}$ and $\theta^{(p,d,k)}$ represent the price and production costs of crop p , irrigation technology k at site d , respectively, $c^{(p,d,k)}$ is the actual yield and $A^{(p,d,k)}$ is the maximum area that can be cultivated for each crop (details on crop water use are represented in Note S1, Figure S2 of Supporting Information S1, and observed irrigated land in Table S1 of Supporting Information S1). The optimized irrigated land is determined based on the optimal water allocated to crops.

The urban benefits UR_t are the sum of each city's consumer and producer surpluses, following (Baccour et al., 2022).

The main constraints of the optimization problem are described as follows:

- *Water balance (hydrological constraint)*

$$s_{t+1} - C^R \cdot (r_t + l_t) - C^I \cdot (i_t) + e_r \cdot (s_t, s_{t+1}) = s_t + q_r \cdot (q_{t-1}, \xi_t) \quad (6)$$

where, variables in bold represent the vector of nodes and t is the time step (monthly). s_t is the storage vector at the beginning of the period t , r_t is the release vector at stage t , q_t is the inflow vector during the time t , i_t is water withdrawals vector. e_t and l_t represent the vector of reservoirs evaporation and the vector of spillage and losses, respectively. The topology of the system is represented using the connectivity matrices C^R (for reservoir releases between reservoirs) and C^I (for return flows).

- Lower and upper bounds on storages

$$\underline{s}_{t+1} \leq s_{t+1} \leq \bar{s}_{t+1} \quad (7)$$

\underline{s}_{t+1} and \bar{s}_{t+1} are the lower and upper bound on storage level respectively, gathered from the historical monthly storage level for each reservoir (CEDEX, 2016).

- Lower and upper bounds on reservoir releases

$$r_t \leq \bar{r}_t \leq \bar{r}_t \quad (8)$$

r_{t+1} and \bar{r}_{t+1} are the lower and upper bound on reservoirs releases. Maximum release is set to account for the river's maximum carrying capacity, depending on the capacity of the hydraulic structures, and minimum release is set at zero.

- Lower and upper bounds on water withdrawals

$$i_t \leq \bar{i}_t \leq \bar{i}_t \quad (9)$$

i_t and \bar{i}_t are the lower and upper bound on water withdrawals. This constraint ensures that the allocation decisions are consistent with the channel capacity (CHE, 2016).

The SDDP is used to solve the optimization problem (Equations 1–9) by breaking down it into a series of one-stage linear problems that are solved recursively (Equation 10). It is built through an iterative procedure to handle the high dimensionality of the problem, aiming to create a locally accurate approximation of the objective function using hyperplanes. The one-stage SDDP optimization problem at stage t during the L th iteration has the following objective function:

$$F_t(s_t, q_{t-1}) = \max_{x_t} \{b_t(s_t, q_t, x_{t+1}) + \alpha_{t+1} \cdot F_{t+1}\} \quad (10)$$

where F_t represents the benefit-to-go function from stage t to the end of the planning period T associated with decision variables vector (release, spillage and losses, end of period storage, and water withdrawals).

The maximization occurs to the extent permitted by the constraints described in Equations 6–9 as well as by the following constraints:

- The Convex hull approximation of the hydropower production

The convex hull is used to deal with the non-linearity of the hydropower production function P_t . The parameters ψ , ω , and δ are estimated using the procedure described by Goor et al. (2011) that eliminates the nonconvexity by creating a piecewise linear approximation of the true hydropower production function through convex hulls [Equation 11].

The hydropower production function is convex with respect to the release and storage, allowing it to be approximated by a convex hull made of multiple planes. The piecewise linear approximation captures the non-linearity of the original production function, which can still be considered in the SDDP algorithm. Since the convex hull inherently provides an upper bound on the original hydropower production function, a correction factor is introduced to ensure that the amount of energy generated with the approximation is similar to the original function.

The procedure to calculate the convex hull parameters is described subsequently: First, the feasible domain of the storage s and the release r of each hydropower station is discretized and the true hydropower function at each grid point is estimated. Then, the upper bound of the hydropower function $\hat{P}(s, r)$ is determined based on the convex hull approximation by the piecewise linear function of the storage and turbinning. The parameters of hyperplanes ($h = 1, 2, \dots, H$) are adjusted in order to minimize the difference between the true non-linear hydropower functions and the piecewise linear approximation.

$$\begin{cases} \hat{P}_t - \psi^{1T} \cdot s_{t+1}/2 - \omega^{1T} \cdot r_t \leq \delta^{1T} + \psi^{1T} \cdot s_t/2 \\ \cdot \\ \cdot \\ \hat{P}_t - \psi^{HT} \cdot s_t/2 - \omega^{HT} \cdot r_t \leq \delta^{HT} + \psi^{HT} \cdot s_t/2 \end{cases} \quad (11)$$

- *The outer approximation of the future benefits (cuts)*

The expected benefit-to-go function F_{t+1} bounded from above by the following inequalities (Equation 12) and obtained by using piecewise linear segments l^{th} (cuts) from sampled states that allows to solve the one stage problem by linear programming.

$$\begin{cases} F_{t+1} - \varphi_{t+1}^1 \cdot s_{t+1} \leq \gamma_{t+1}^1 \cdot q_t + \beta_{t+1}^1 & (l = 1, 2, \dots, L) \\ \cdot \\ \cdot \\ F_{t+1} - \varphi_{t+1}^L \cdot s_{t+1} \leq \gamma_{t+1}^L \cdot q_t + \beta_{t+1}^L \end{cases} \quad (12)$$

where L is the total number of cuts (hyperplanes), and $\varphi_{t+1,l}$ and $\gamma_{t+1,l}$ are the gradients of F_{t+1} regarding the state variables (s_{t+1}, q_t) , and β_{t+1} is the intercept. These cuts parameters are calculated at stage $t+1$ based on the primal and dual information available at the optimal solution of the one-stage SDDP problem (Tilmant et al., 2008), (Note S2 and Figure S3 in Supporting Information S1).

While the storage states s_t are experimented from the minimum and maximum storage capacity of each reservoir, the hydrological states q_{t-1} are experimented from historical flow records in the baseline conditions or from inflows projections under the future climate scenarios. Stochastic inflows are generated at stage t using a multisite periodic autoregressive model (MPAR), whose parameters are derived from known inflows values (historical and projection inflows). The MPAR is capable of representing seasonality, serial, and spatial streamflow correlations within a river basin, capturing hydrologic uncertainty and guaranteeing the convexity requirement of the SDDP (Espanmanesh & Tilmant, 2022; Pina et al., 2017). At each site j , the hydrologic process can be derived from:

$$\left(\frac{q_t(j) - \mu_{q_t}(j)}{\sigma_{q_t}(j)} \right) = \phi_t(j) \cdot \left(\frac{q_{t-1}(j) - \mu_{q_{t-1}}(j)}{\sigma_{q_{t-1}}(j)} \right) + \xi_t(j) \quad (13)$$

where q_t is the inflows at time t , with $t = 1, 2, \dots, 12$ months μ_{q_t} and σ_{q_t} are the periodic means and standard deviation of q_t , respectively and the ϕ_t is the autoregressive parameter of the periodic model. ξ_t is a time independent-spatially correlated stochastic noise.

The simulation of optimal allocation policy decision is determined from the SDDP results based on the re-optimization procedure described by Tejada-Guibert et al. (1993) with SDP and applied by Tilmant et al. (2020) with the SDDP. The approach is based in using the 12 monthly piecewise linear functions determined from the intermediate year in simulation over the entire streamflow record. The re-optimization problem at time t (year y and month m) is:

$$Z = \max_{x_t} \{b_m(s_t, q_{y,m}, x_t) + F_{m+1}\} \quad (14)$$

Subject to

$$s_{t+1} - C^R(r_t + l_t) - C^I(i_t) + e_t(s_t, s_{t+1}) = s_t + q_{y,m} \quad (15)$$

$$F_{m+1} - \varphi_{m+1,l}^r s_{t+1} \leq \gamma_{m+1,l}^r q_{y,m} + \beta_{m+1,l} \quad (l = 1, 2, \dots, L - 1) \quad (16)$$

Equations 2–6 stated in the one-stage optimization problem are both applicable. Once the re-optimization problem is solved, the system moves to time $t + 1$ using the mass balance (Equation 11) and solving a new re-optimization problem. This process continues until the end of the simulation period is reached.

The simulated allocation decisions for each year and month (30 years \times 12 months) obtained from the re-optimization procedure for each scenario (baseline; CC-2070; CC-2100) are processed to calculate the performance indicators. The selected performance indicators are related to each management objective (economic activity) to assess the probabilistic trade-offs between economic sectors and spatial locations.

Indicators for assessing the trade-offs between economic sectors: (Five performance indicators of which three are related to the irrigated agriculture sector and one for each of the energy and urban sectors).

For irrigated agriculture: the three performance indicators are the effective irrigated area for field crops, vegetables, and fruits tree. The performance indicator for each group represents the number of irrigated hectares (ha) effectively supplied during the simulation period. The effective irrigation area is assumed to be proportional to the ratio between the volume of water effectively supplied to the crop during the irrigation season and the seasonal crop water requirement.

For hydropower generation: the performance indicator is the annual energy production of all hydropower plants in the system.

For the urban sector: the performance indicator is the volume of water supplied to cities.

Indicators for assessing the trade-offs between spatial locations: (six performance indicators, one per management objective for the upstream and downstream areas). The indicators include irrigated area for agriculture, hydropower generation for energy, and urban water use, both for upstream and downstream areas.

In this study, the re-optimization procedure is performed for both historical (baseline) and future climate streamflows. This procedure is critical for assessing the performance of the system under historical and future drought conditions in hydrologic sequences that show the effects of extreme drought events.

2.3. Procedure to Identify Trade-Offs

The optimization-re-optimization process is applied for baseline and for future climate scenarios (CC-2070; CC-2100) under two alternative water allocation policies: agricultural production priority or energy production priority. The re-optimization procedure for each climate scenario and each policy over 30 years delivers vectors for each performance indicator (30 \times 1). These vectors are used to identify trade-offs between sectors and spatial locations described above.

A variety of visualization techniques can be used to identify trade-offs between multiple elements and dimensions, such as Parallel Coordinate Plots and Radar Charts. These interactive visualization frameworks facilitate the identification of the Pareto optimal solution, especially in high dimensional systems that need sophisticated representations of properties such as color, shape, etc (Giuliani et al., 2015; Hurford et al., 2014; Tilmant et al., 2020). In this study, Parallel Coordinate Plots (PCP) are used to represent and identify trade-offs between sectors and spatial locations for each climate scenario and policy. In the PCP, the different performance indicators are displayed as equally spaced vertical lines (Y -axis). The performance indicators are represented on the X -axis, while the increasing preferences are on the Y -axis. The Y -axis scale is determined based on the re-optimization results for each performance indicator over the simulation periods and corresponds to the minimum (the bottom horizontal axis) and maximum (the top horizontal axis) values of that indicator across all scenarios. The average of the performance indicator over the simulation period is represented by a dotted line. The

distribution of the performance indicator is characterized by colored areas associated with quantiles. These areas explain the response of performance indicators to changing water stress conditions under each policy. The orange area represents the first quartile (25%), with the lowest values of performance preference. The green area is the interquartile range between the 25th and 75th percentile; and the blue area includes the highest values, above the 75th percentile. The comparison of plots shows the change in trade-offs between climate scenarios and policies, showing the impacts of priority policies and hydrologic uncertainty (Figure S5 in Supporting Information S1).

2.4. Policies and Climate Scenarios

In terms of water resources allocation, priority policies are used to evaluate the consequences of different priorities assigned to the main economic sectors: agriculture (food security) versus hydropower (energy security). In this study, the urban sector is given priority under both intervention policies based on the current water management rules of the Ebro water authority that prioritizes water allocation for the urban sector in drought conditions. We assume that the annual urban water consumption should be satisfied by at least 95% under both priority policies. The agriculture priority implies the re-operation of the reservoirs to release water in the areas with large agriculture activities, maximizing the agricultural benefits, while the energy sector maximizes its benefits to the extent possible. In the agriculture priority scenario, irrigation withdrawals are additional constraints to the optimization problem. These constraints can be classified as either hard or flexible. Hard constraints mean that water withdrawals will always be met as long as there is water available. Flexible constraints mean that irrigation deficits are penalized in the objective function, that is, irrigation withdrawals can be lower than expected (and thus there is a deficit) in case of reduced water availability. In the energy priority scenario, the irrigation constraints mentioned above are relaxed and water is allocated primarily to produce energy.

The selected priority policies affect three important objectives: human water security, food security, and energy security. Human water security will remain under threat in the future because of the escalating trends in human population, climate stress, water use, and development pressures (Vorosmarty et al., 2010). Access to safe drinking water and sanitation are basic human rights and are prerequisite to achieving many dimensions of sustainable development including health and food security. The challenge of meeting future water needs in a sustainable manner requires the implementation of integrated water resources management and efficient water planning (UN, 2018). Food security and agricultural sustainability are particularly challenging during droughts, requiring urgent action in both developing and developed countries (Gil et al., 2019). Ensuring food security is an important target of the sustainable development goals (SDG) for reducing hunger and extreme poverty, and achieving good health and wellbeing. Energy security is a key issue in Europe for adaptation and mitigation of climate change. In Spain, the Integrated National Plan of Energy and Climate 2021–2030 and the Energy Security Enhancement Plan regulate the measures and investments for the development of renewable energies, including the target of 74% of renewable energies in electricity generation by 2030 (MITECO, 2020, 2022).

The model was first run and calibrated to reproduce observed hydrological and economic data in baseline conditions (Table S1 in Supporting Information S1) and then used to assess three climate water stress scenarios for each priority policy in the Ebro basin: Baseline, CC-2070, and CC-2100. The historical river discharge of the Ebro has been affected by climate variability, resulting in moderate climate water stress, especially in the years 1989, 2005, and 2012. The future climate water stress scenarios are based on the projected future declines in streamflow under climate change. The projected monthly streamflow in each headwater over the simulation periods for each climate scenario CC-2070 and CC-2100 are determined by perturbing the historical series with the levels of water stress. The levels of water stress are based on the climate change projections provided by CEDEX (2017) that are built on the Integrated System of Modeling Precipitation-Delivery (SIMPA) by downscaling the outputs from Global Climate Models (GCM) at Spanish basin scale. The CEDEX results have a spatial resolution of 1 km for the RCP4.5 and RCP8.5 emission scenarios and take account of changes in the frequency of droughts with different intensity and duration. In this paper, the worst-case scenario RCP8.5 is selected to demonstrate which would be the optimized water allocations under future and extreme weather circumstances. The level of water reduction would be 12% for CC-2070 and 24% for CC-2100 scenarios (Table S2 and Figure S1 in Supporting Information S1).

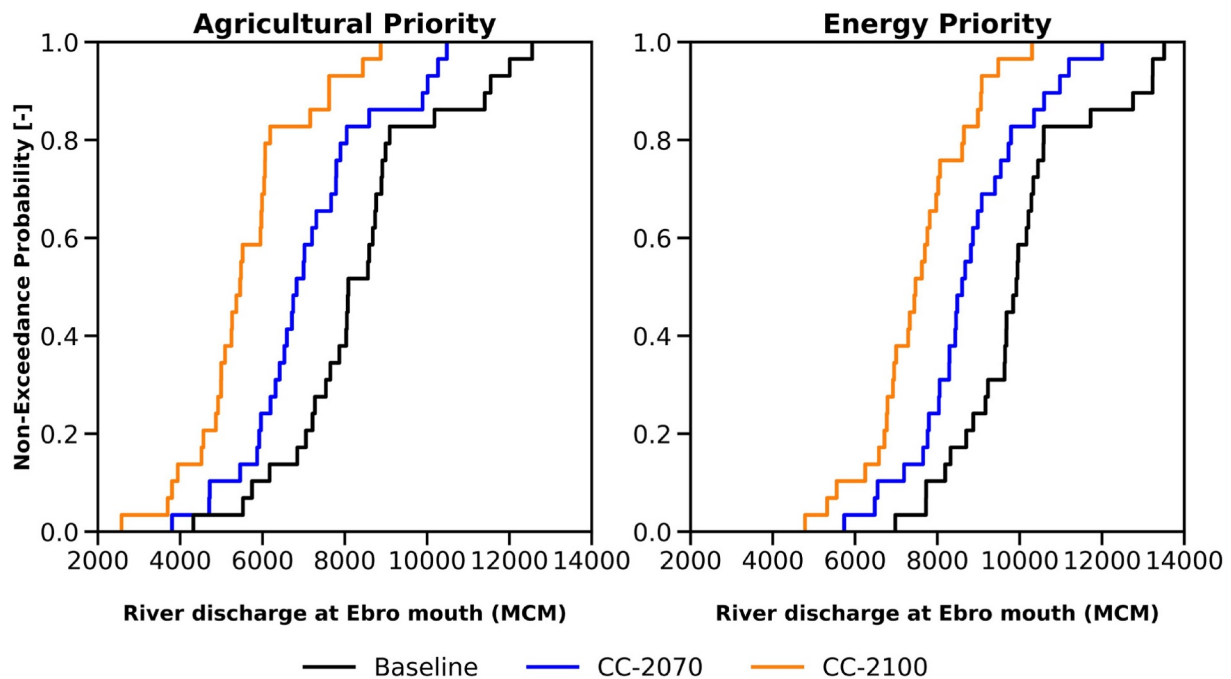

Figure 3. Empirical cumulative probability distribution functions of the model-projected annual outflows at the Ebro River mouth for baseline, CC-2070, and CC-2100 periods under energy and agricultural priority.

3. Results

3.1. Hydrologic and Economic Impacts of Climate Risks

The empirical cumulative distribution of annual outflow at the Ebro River mouth under climate water stress scenarios (CC-2070 and CC-2100) and priority policies is shown in Figure 3. Based on the SDDP simulations under historical climate conditions, the optimal annual outflow for 50% non-exceedance probability is estimated to be 8,080 and 9,910 Mm³ under the agriculture and energy priority policies, respectively. The energy priority policy involves higher stream flows at the Ebro River mouth because of the reduced water consumption in irrigation. Therefore, there are larger reservoir releases for optimal hydropower generation. The water use by irrigated areas is done only by the extent permitted by the energy and urban sectors. The energy priority policy could have the advantage of alleviating water scarcity in the downstream of the Ebro basin by satisfying agricultural and urban demand, while rising energy production and water stream flows. Therefore, water and energy security are enhanced. Overall, under future climate water stress scenarios, the annual outflow at Ebro River mouth is projected to be smaller for both priority policies in comparison with the historical outflow.

For agricultural priority, water use by irrigated agriculture is reduced by around 8% (−158 Mm³ for CC-2070; −183 Mm³ for CC-2100), water use for energy production decreases by up to 28% (−2,430 Mm³ for CC-2070; −5,292 Mm³ for CC-2100), and urban water use is maintained, compared to historical conditions. The annual outflow at the Ebro River mouth falls to 6,830 Mm³ under CC-2070 climate scenario, and to only 5,450 Mm³ under CC-2100 climate scenario. However, for the energy priority, the annual outflow will exceed 8,600 and 7,470 Mm³ for 2070 and 2100, respectively, with a 50% exceedance probability. The high outflow levels under energy priority are due to the increased reservoir releases (+1,370 Mm³ for CC-2070; +4,491 Mm³ for CC-2100) that maximize hydropower generation, compared to agriculture priority outflows at the Ebro mouth.

Projected annual hydropower production, irrigated cropland, and urban water use in the Ebro River basin for baseline, CC-2070 and CC-2100 scenarios under the agriculture and energy priority policies are shown in Figure 4. The urban sector takes priority over all other water uses and the annual urban water withdrawals are maintained under both policies and future climate scenarios, promoting the human water security objective. The annual hydropower production for current climate conditions and 50% non-exceedance probability is estimated at 4,030 GWh under agricultural priority, which is considerably smaller than under energy priority

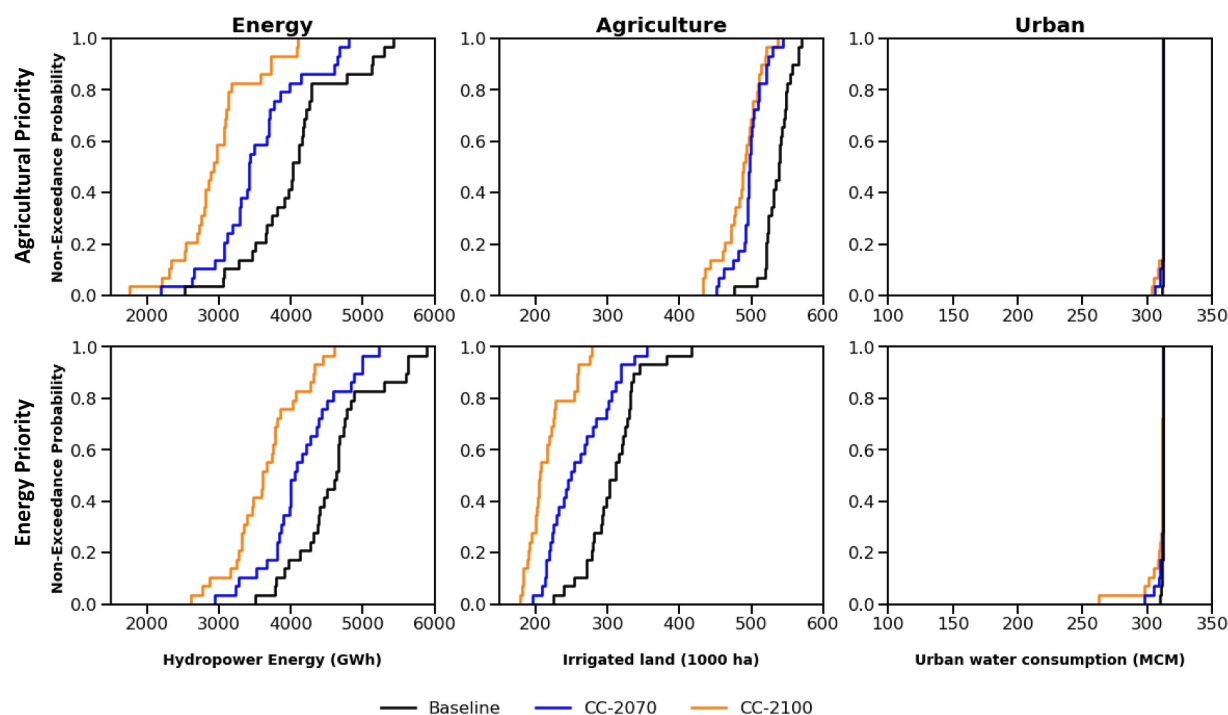

Figure 4. Empirical cumulative probability distribution functions of the model-projected annual hydropower, irrigated land, and urban water use for baseline, CC-2070 and CC-2100 periods under energy and agricultural priority.

(−13%; 4,640 GWh). The hydropower production is expected to decrease under future climate water stress scenarios because of the falling streamflow in the basin. Compared to the baseline, hydropower production decreases by almost 30% (at 2,930 GWh) under agricultural priority, while decreasing only by 20% (3,610 GWh) under energy priority for the CC-2100 scenario. The reduction in hydropower generation is substantial under agricultural priority compared to the energy priority policy. The projected irrigated land for current climate conditions under agricultural priority is 538,000 ha for an exceedance probability of 50%, while under the energy priority, the irrigated land with a 50% exceedance probability is only 311,000 ha. In both future climate scenarios, the reduction in irrigated land is below 10% compared to the baseline (538,000 ha) under agricultural priority. However, irrigated cropland falls by 20% (to 249,000 ha) and 34% (to 206,000 ha) relative to the baseline (311,000 ha) under the energy priority for the CC-2070 and CC-2100 scenarios, respectively.

3.2. Probabilistic Trade-Offs Between Competing Water Users and Spatial Locations

Figures 5 and 6 show the trade-offs between economic activities and between spatial locations in the basin, by priority policy and climate scenario. Assessing the probabilistic trade-offs and performance of each sector (agriculture, energy, and urban) under uncertainty using the SDDP algorithm requires stochastic inflows generated by a multisite periodic autoregressive model. The SDDP model is an effective tool for optimizing reservoir operations amidst uncertain inflows. This approach allows the model to account for multiple inflow sequences, enabling the development of robust operational strategies across different hydrological conditions. Espanmanesh and Tilmant (2022) indicate that SDDP could accommodate system and hydrologic complexity including a large number of reservoirs and diverse hydrologic information. The stochasticity captured by hydrologic uncertainty could provide a hedging strategy against extreme hydrologic events and economic risks. The probabilistic trade-offs analysis accounts for the variability and randomness of hydrologic events and provides the distribution of each performance indicator under priority policy and climate scenario (Tables S7 and S8 in Supporting Information S1). The results show the trade-offs among economic sectors, agricultural subsectors, and upstream-downstream spatial locations, delivering a nuanced understanding of sectors vulnerability and the

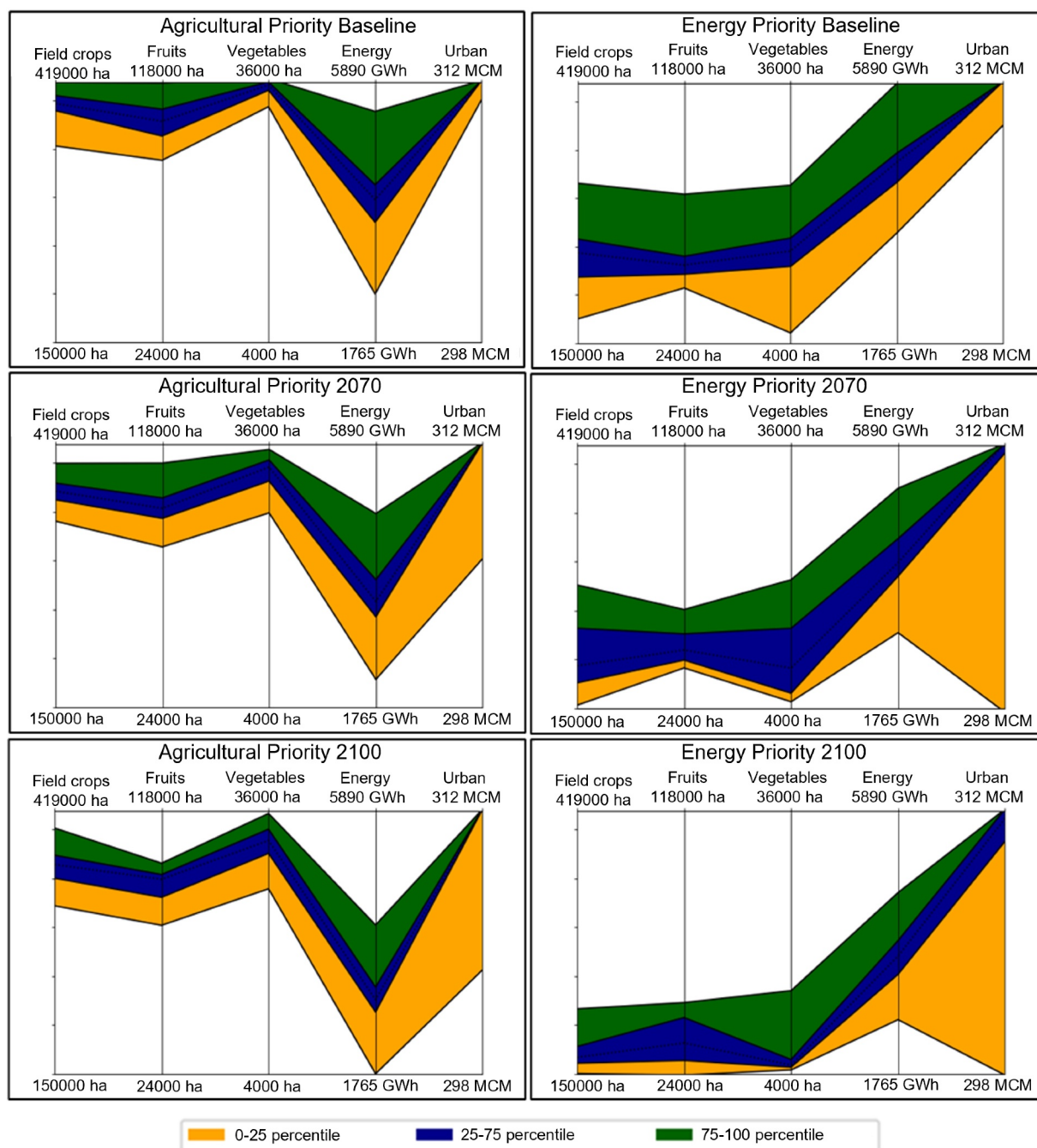

Figure 5. Trade-offs among sectors for baseline, CC-2070 and CC-2100 periods under energy and agricultural priority.

associated hydrologic and economic risks under different policies and climate scenarios. The magnitude of trade-offs reveals their sensitivity to water stress from climate conditions.

Under future climate scenarios, the agricultural priority policy considerably reduces energy generation to 1,765 GWh (−56%), while slightly decreasing the irrigated area of field crops (−7%), fruits (−12%), and vegetables (−6%) for a 75% exceedance probability in 2100 (Figure 5). This prioritization of the agriculture sector leads to increasing competition for water, affecting the availability of water for the energy sector and damaging hydropower production. The decline of water accessibility for energy generation is explained by the large irrigation withdrawals to achieve food production targets, which resulted in lower basin stream flows. Water is used

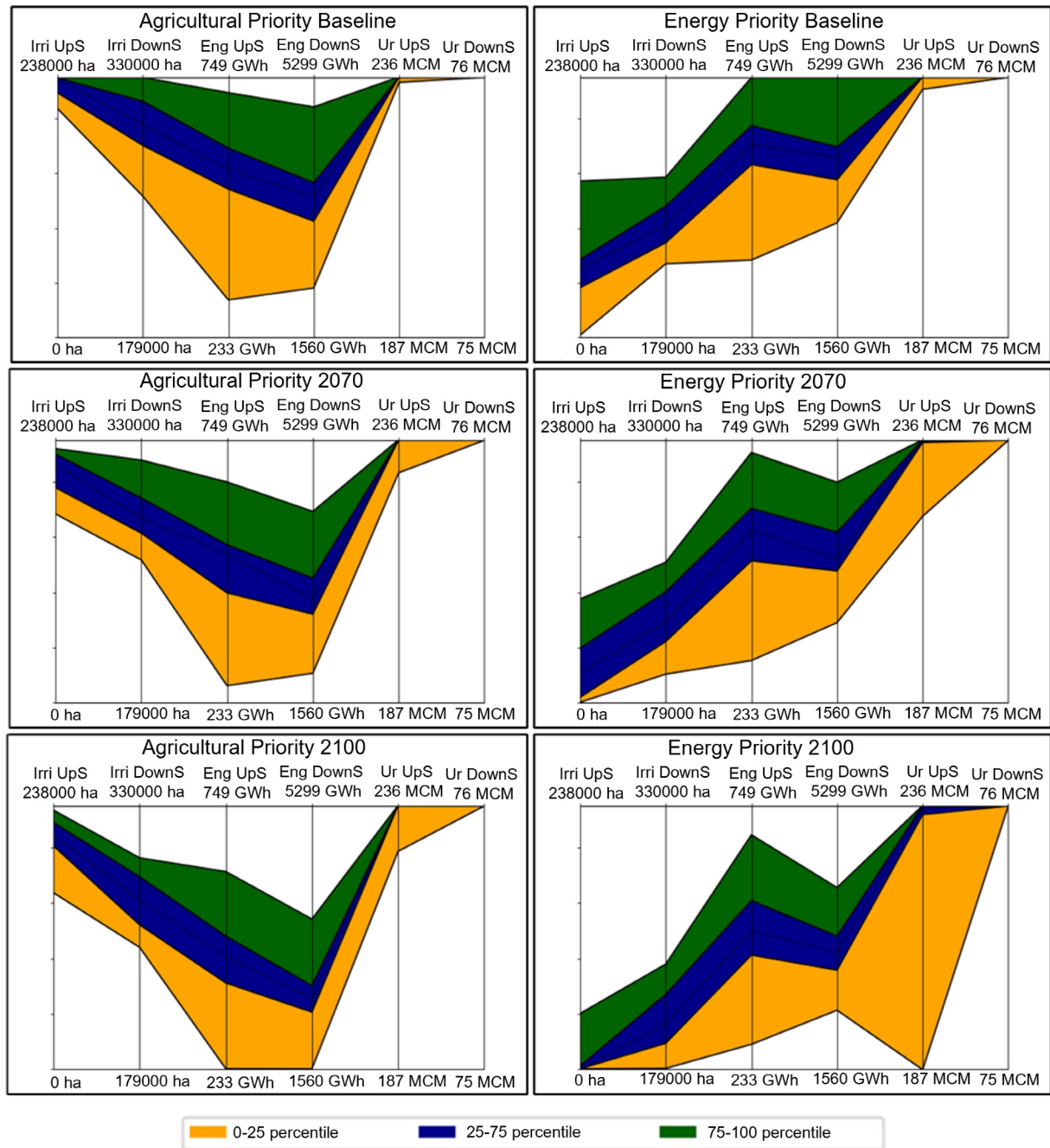

Figure 6. Trade-offs among sectors by spatial location (upstream-downstream) for baseline, CC-2070 and CC-2100 periods under energy and agricultural priority.

for energy production only to the extent permitted by the irrigation-oriented reservoir releases, and the resulting higher irrigation evapotranspiration which depletes stream flows in the river. The agriculture priority shows the energy sector's lower performance and higher vulnerability to climate conditions. In contrast, the energy priority policy increases hydropower production to 5,218 and 4,609 GWh for 2070 and 2100 respectively, reduces the performance of agriculture, and maintains urban water use. There is a large reduction in the production of field crops (−31%), fruits (−20%) and vegetables (−66%) compared to agricultural priority for a 75% exceedance probability in 2100 (Table S7 in Supporting Information S1, Figure 5). This reveals the trade-offs between energy and agriculture, which are an important consideration for decision making. Climate water stress reduces crops with low profitability and high-water requirements, and the cropland acreage under less efficient irrigation

technologies. The responses of different crops to water shortages are explained by the demand elasticity of each crop. Crops with more elastic demand are more sensitive to changes in price (and thus changes in water availability) compared to crops with less elastic demand. Water use in urban centers is met with a reliability of 95% under both agricultural and energy priority policies for all climate scenarios, achieving human water security. This is explained by the low urban price elasticity of demand, which leads to smaller reductions in urban economic welfare compared with agricultural and energy welfare.

The intra-sectoral trade-offs between agricultural subsectors can be expected especially under energy priority policy (Figure 5). These trade-offs arise due to limited water resources to cover crop water requirements in all irrigation districts and the need to maximize the economic benefits of all sectors and achieve the energy production target under the energy priority policy. The energy priority could reduce field crops, vegetables, and fruit trees to 150,000; 4,000; and 24,000 ha in 2100 (Table S7 in Supporting Information S1). A considerable reduction of vegetables (−42% in 2070; −67% in 2100), and field crops (−21% in 2070; −31% in 2100) is sustained for a 50% exceedance probability under energy priority when water scarcity intensifies. However, the agricultural priority slightly reduces the area of field crops (−7%), fruits (−9%) and vegetables (−8%) for a 50% exceedance probability in 2070 and 2100 (Figure 5). For the energy priority policy, the probability of the area of field crops and vegetables falling below 218,000 ha and 14,000 ha, respectively, is close to 25% in the baseline. This probability rises to around 75% in 2070 and 100% in 2100, highlighting the vulnerability of field crops and vegetables to climate water stress. The probability of the area of fruits falling below 44,000 ha is 0% in the baseline, and around 50% in 2070 and 75% in 2100, showing that fruits are less vulnerable to climate water stress than field crops and vegetables. The substantial decrease in field crops and vegetables under energy priority is due to the low profitability and high-water requirement linked to outdated irrigation technology (surface irrigation).

As mentioned above, the agricultural priority policy results in low performance and high vulnerability of hydropower production under water stress conditions. However, the vulnerability level depends on the spatial location and the economic value of hydropower plants. Figure 6 and Table S8 in Supporting Information S1 show that under agricultural priority, downstream hydropower generation decreases by 15% in 2070 and 28% in 2100 for a 50% non-exceedance probability, while upstream hydropower generation declines only by 7% in 2070 and 20% in 2100. This indicates that downstream hydropower production is more vulnerable than upstream hydropower production.

Despite the slight vulnerability of the agriculture sector under agricultural priority, agriculture downstream is more impacted (−6% in 2070 and −8% in 2100) than agriculture upstream under future climate scenarios for a 75% non-exceedance probability (Figure 6). This indicates that agriculture downstream is more vulnerable than agriculture upstream. The reason is the high-water requirement and low value of some crops in the downstream irrigated areas which make the agriculture upstream has the advantage of using water from inflows and reservoir releases.

The energy priority policy decreases upstream irrigated area by 89% and 57% in 2070 and by 100% in 2100, for 25% and 50% non-exceedance probabilities, respectively. However, the downstream irrigated area decreases only by around 8% in 2070 and 17% in 2100 for both 25% and 50% non-exceedance probabilities (Figure 6 and Table S8 in Supporting Information S1). The low vulnerability of downstream irrigation is explained by the high hydropower production downstream, which delivers large reservoir releases to irrigation downstream. More details about the energy production, irrigated areas and optimized water use by location and sector under climate scenarios and policies are available in Tables S3–S6 of Supporting Information S1.

Benefits from hydropower, irrigation and urban supply decrease under future climate scenarios (CC-2070 and CC-2100) for both priority policies. For the CC-2100 scenario, average annual agricultural benefit falls by 8% and 23% under agricultural and energy priorities, and average annual energy benefit falls by 27% and 21% under agricultural and energy priorities, respectively (Table S9 in Supporting Information S1). The implication is that the agricultural priority promotes food security and energy priority promotes energy security. However, agricultural priority worsens the performance and increases the vulnerability of hydropower, and energy priority has the same negative effect on agriculture. Results on basin-wide benefits indicate the trade-offs of shifting from agricultural to energy priority: agriculture benefit losses would be close to 50% (43% in baseline, 46% in 2070, and 52% in 2100), while energy benefit gains would be close to 20% (14% in baseline, 17% in 2070, and 23% in 2100) (Table S9 in Supporting Information S1).

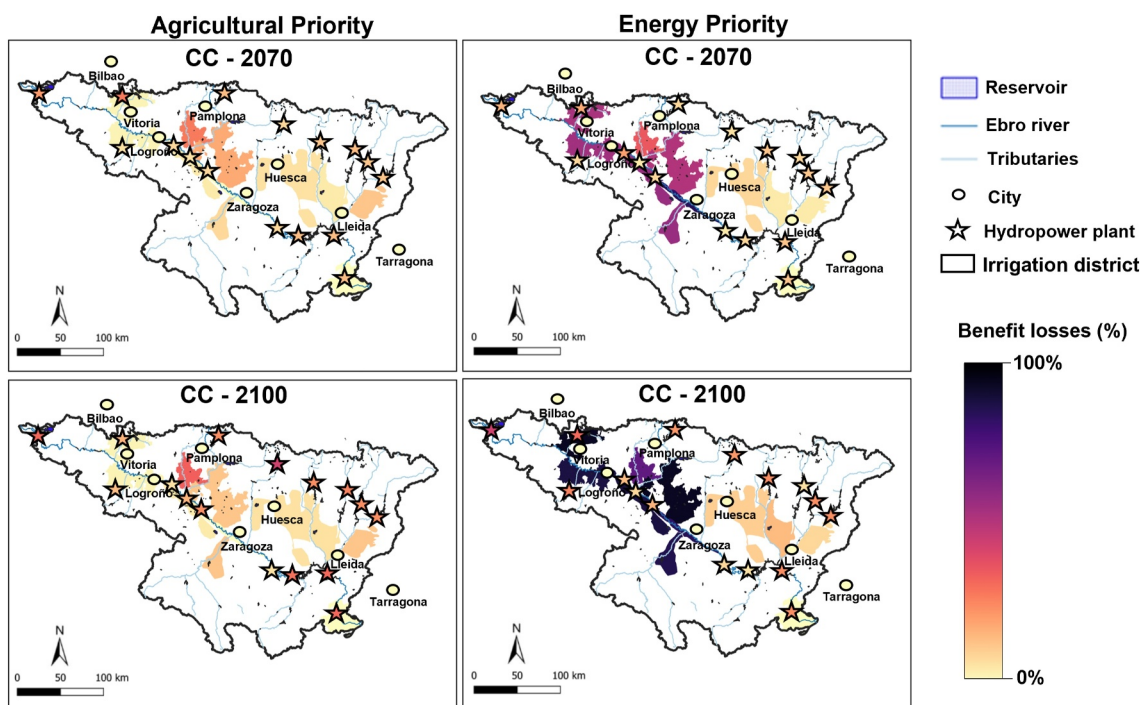

Figure 7. Benefit losses by sector under future climate scenarios.

The costs of climate change for irrigation districts and hydropower plants by spatial location are presented in Figure 7 and Table S9 of Supporting Information S1. This information provides a better understanding of the vulnerability of sectors across locations in the basin. Under energy priority, upstream irrigation districts would lose 57% of their benefits for CC-2070 and 95% for CC-2100 climate scenarios. This demonstrates how climate water stress coupled with energy priority, increases the likelihood of irrigation losses up to the point of threatening the continuation of upstream irrigation activities. Benefits of downstream irrigation districts are less affected by future water stress coupled with energy priority, because they take advantage of large reservoir releases that maximize downstream hydropower production.

Under agricultural priority, benefit losses of downstream hydropower could reach 45% for the CC-2100 climate scenario, while benefits of upstream hydropower plants would be only slightly reduced (Figure 7). This is explained by the advantage of hydropower in upstream areas that can use water from headwaters and reservoir releases, whereas hydropower downstream is faced with depleted stream flows since more water is consumed by irrigation districts under agricultural priority.

4. Discussion and Policy Implications

This paper develops a stochastic hydro-economic model in the Ebro basin. The purpose is to assess different water allocation policies to confront future climate water stress, considering the interaction between water, energy, and agricultural systems. The results of this study highlight the importance of selecting adequate water policies for sustainable and effective water allocation among all sectors and spatial locations under future climate conditions. The analysis of hydrologic risks indicates reductions in stream flows under both climate change scenarios (CC-2070; CC-2100), which are consistent with the results of other studies. Pulido-Velazquez et al. (2021) indicate that there would be substantial streamflow reductions in Spain's northern basins, and Lopez-Moreno et al. (2014) estimate a 14% decrease in stream flows in the Pyrenees from the projected trend of warming for the period 2021–2050.

The study estimates the impacts of future climate water stress on both water demand and supply by sector and location. Under climate change, there is competition between food security, energy security and human water security in urban centers. Our results indicate that human water security is achieved under both priority policies and climate scenarios. They also demonstrate that choosing a policy of agricultural priority worsens the

performance and increases the vulnerability of hydropower. Conversely, selecting a policy of energy priority increases the vulnerability of irrigated agriculture. Wu et al. (2021) indicate that boosting food production reduce hydropower generation. Tilmant et al. (2020) indicate that food production is highly vulnerable to changes in hydro climatic conditions and allocation policies in the case of the Senegal basin, emphasizing the importance of factoring this vulnerability into schemes for water and benefit sharing negotiations.

Understanding the trade-offs among spatial locations by sector is indeed crucial for improving the knowledge required for strengthening food, energy and human water security. Findings show that the energy priority policy reduces water supply to upstream irrigation schemes, with substantial benefit losses in upstream agriculture. Conversely, the agricultural priority policy would damage hydropower generation downstream, where the larger hydropower plants are located, because upstream withdrawals by irrigation districts deplete downstream river flows used for hydropower. Although hydropower production does not consume water, the seasonality of releases and the spatial location of plants may have strong impacts on river flows. These flow changes could lead to conflicts between large hydropower plants downstream and upstream irrigation districts. The same dilemma is found by Jalilov et al. (2016) in the Amu Darya River Basin in the assessment of alternative priority policies. They indicate that energy priority ensures more energy production by Tajikistan but dwindling agricultural benefits in downstream countries, while agricultural priority brings more agricultural benefits to Tajikistan and Uzbekistan. They stress the importance of seasonality and timing in reservoir releases for the performance of energy production and irrigated agriculture.

The study demonstrates that the urban sector bears the lion's share of economic benefit under both agriculture and energy priority policies. Climate stress has a slight impact on urban benefits under energy priority (-0.4% for CC-2100 for 25% non-exceedance probabilities), while it remains unaffected under agriculture priority across the 25%, 50%, and 75% non-exceedance probabilities. The energy and agriculture priority ensures the achievement of the targeted irrigated and hydropower production, leading to a distribution of benefits where the energy and agriculture sectors perform according to their priorities (Figure S4 in Supporting Information S1). The water resources allocation under each policy and climate scenario directly influences the distribution of economic benefits, reflecting the sectors' performance. Understanding the probabilistic trade-offs between economic benefits under policies and climate scenarios provides a more comprehensive grasping of the complexities and uncertainties involved in water resource management under climate change. This information allows policy-makers to make better informed decisions that balance economic benefits across sectors while accounting for the inherent uncertainties in climate projections.

The complexity of adaptation efforts requires careful consideration of trade-offs among sectors and location. Torhan et al. (2022) demonstrate that trade-offs could result from adaptation responses that appear in the form maladaptation responses and limitations, which potentially rise risks in the adaptation of another sector and exacerbate vulnerabilities. De Vos et al. (2021) highlight the need to simultaneously consider different dimensions of the nexus when developing scenarios that aim to achieve multiple sustainability targets. Understanding trade-offs and the interconnectedness of different sectors and their spatial location in an integrated ways could anticipate unintended consequences for developing effective and sustainable adaptation strategies that minimize risks, vulnerabilities, and economic losses, and for enhancing resilience in the face of evolving water and climate challenges. Identifying vulnerabilities can be valuable tools for conservation and climate adaptation planning (Schmidt et al., 2023).

Our study extends the application of the Stochastic Dual Dynamic Programming (SDDP) algorithm, traditionally used to explore sectoral trade-offs, by incorporating an analysis of the spatial dimensions and interactions of these sectors under future climate scenarios. The model addresses the gap in understanding how spatial and sectoral dynamics interact, particularly in the context of increased water stress and climate variability, taking the Ebro River basin in northeast Spain as a key case study. This Mediterranean basin faces serious challenges including seasonal water scarcity, water demand sector competition and water stress and variability intensification. The model includes sectoral preferences, priorities, and hydrologic and economic constraints for each policy and climate scenario, enhancing its ability to consider the needs and constraints of selected sectors and locations. This enables a nuanced examination of how different water allocation policies affect each sector under baseline and future climate conditions. It addresses the basin's challenges by revealing probabilistic trade-offs, identifying vulnerable objectives, enhancing cross-sectoral planning, and fostering wider approval and support for a sustainable and effective water planning system. Moreover, the projected

future hydrologic data for each spatial location is derived from the model predictions of CEDEX (2017) and the SIMPA model in the Ebro basin. Those predictions have a spatial resolution of 1 km for each emission scenario and account for changes in the frequency of droughts of different intensity and duration, dealing with spatial variability and climate uncertainty.

Our paper contributes to several aspects: (a) Identifying the probabilistic trade-offs among sectors, intra-sectors and spatial locations in the basin under future climate scenarios and priority policies, highlighting their vulnerability to climate water stress. The model's capacity to provide optimized solutions for all sectors and locations under varied future climate conditions demonstrates the model's sensitivity to parameter changes and qualifies it for effective policy support. The trade-offs analysis could inform a nexus dialog between sectors for supporting the science-informed design of efficient, flexible, and equitable cross-sectoral water planning and promoting sustainable development. Identifying those trade-offs is a prerequisite toward the development of adapted and socially acceptable allocation policies between sectors and spatial locations, and for supporting the collective action of stakeholders and decision-makers to advance sustainable water management coupled with food, energy, and human water security. (b) Assessing the economic losses by sector and spatial location and informing the targeted policy recommendations for each specific area. (c) And analyzing the hydrologic risks associated with future climate water stress and the impending economic risks for each sector. In the context of limited resources, optimization models can ensure that resources are allocated most efficiently, achieving the maximum possible impact for the given constraints. This efficiency can make plans more feasible by fitting within budgetary and resource limitations, reducing future uncertainty.

A certain number of simplified assumptions have been undertaken in the modeling approach. The stochastic optimization model presents ongoing debates only between irrigated agriculture, urban supply and energy sectors. The inclusion of other important competing water users such as environmental flows for ecosystems could improve the assessment of the probabilistic trade-offs between sectors. This will guide a broader sectoral scope for efficient water allocation under future climate water stress. The projections of future hydrologic data that are used in this study are focused on the worst-case scenario of RCP8.5 and represent an average combination of diverse climate models. Examining the probabilistic trade-offs for each climate model separately and also for the RCP4.5 scenario could provide a more extensive spectrum of changes in order to better deal with uncertainty. Despite these limitations, our modeling approach generates useful insights for improving cross-sectoral planning, achieving equitable trade-offs with the support of stakeholders, adapting to future climate water stress, and providing policymakers with inspiring messages for the design and implementation of efficient and feasible water allocation policies.

5. Conclusions

This study develops a stochastic optimization model (SDDP) for the Ebro basin to identify the vulnerability of the economic sectors to hydrological risks, and the response through alternative priority policies that result in gains and losses among sectors and spatial locations. The probabilistic trade-off analysis shows the ranges of vulnerability for agriculture and hydropower, depending on the goals embodied in the policy priorities of decision makers. The policies of agricultural or energy priority combined with the spatial locations of irrigation schemes and hydropower plants, determine stream flows across the basin and water withdrawals to competing sectors. Climate change could result in up to a 95% loss of benefits for upstream irrigation districts under energy priority and up to a 45% loss of benefits for downstream hydropower under agriculture priority by CC-2100. This results in dramatically different benefit gains and losses by sector and location (Table S9 in Supporting Information S1). However, neither priority policy provides an equitable sharing of benefits among all sectors and spatial locations under climate change. This fact emphasizes the difficulties of reaching win-win outcomes that would enhance food, energy and human water security in large river basins. However, identifying the economic losses for each sector and spatial location could help policymakers and stakeholders to minimize the impact of water stress and make more informed decisions to enhance resilience and sustainability in the face of water-related challenges. Additionally, the information on probabilistic trade-offs contributes to the design of water management policies that could handle the challenges posed by climate water stress, by reducing economic losses with possible compensations in order to achieve acceptable levels of energy, agricultural and human water security.

Data Availability Statement

The input data underlying the reported research, along with a detailed description of each model parameter are made available at Zenodo via <https://doi.org/10.5281/zenodo.14283046>. *Software Availability Statement:* The software employed for postprocessing the SDDP model large amount of simulation outputs, and for analyzing and visualizing the results in this research are made available in the Zenodo repository under accession code <https://doi.org/10.5281/zenodo.14283046>.

Acknowledgments

The authors acknowledge the Spanish Ministry for Science and Innovation for funding the development of this research as part of the INIA RTA2017-00082-00-00 and PID2020-440 115495RA-I00 projects, partly financed by European ERDF funds.

References

- Baccour, S., Albiac, J., Kahil, T., Esteban, E., Crespo, D., & Dinar, A. (2021). Hydroeconomic modeling for assessing water scarcity and agricultural pollution abatement policies in the Ebro River Basin, Spain. *Journal of Cleaner Production*, 327, 13. <https://doi.org/10.1016/j.jclepro.2021.129459>
- Baccour, S., Albiac, J., Ward, F., Kahil, T., Esteban, E., Uche, J., et al. (2024). Managing climate risks: New evidence from integrated analysis at the basin scale. *International Journal of Water Resources Development*, 25.
- Baccour, S., Ward, F. A., & Albiac, J. (2022). Climate adaptation guidance: New roles for hydroeconomic analysis. *Science of the Total Environment*, 835, 14. <https://doi.org/10.1016/j.scitotenv.2022.155518>
- Bellman, R. (1957). *Dynamic programming* (1 ed.), Princeton University Press.
- Brodeur, Z. P., Herman, J. D., & Steinschneider, S. (2020). Bootstrap aggregation and cross-validation methods to reduce overfitting in reservoir control policy search. *Water Resources Research*, 56(8). <https://doi.org/10.1029/2020wr027184>
- Brown, C., Ghile, Y., Lavery, M., & Li, K. (2012). Decision scaling: Linking bottom-up vulnerability analysis with climate projections in the water sector. *Water Resources Research*, 48(9), 12. <https://doi.org/10.1029/2011wr011212>
- Busoniu, L., Ernst, D., De Schutter, B., & Babuska, R. (2011). Cross-entropy optimization of control policies with adaptive basis functions. *IEEE Transactions on Systems, Man, and Cybernetics—Part B: Cybernetics*, 41(1), 196–209. <https://doi.org/10.1109/tsmcb.2010.2050586>
- Cai, X. M., Wallington, K., Shafiee-Jood, M., & Marston, L. (2018). Understanding and managing the food-energy-water nexus—Opportunities for water resources research. *Advances in Water Resources*, 111, 259–273. <https://doi.org/10.1016/j.advwatres.2017.11.014>
- Cammalleri, C., Naumann, G., Mentaschi, L., Formetta, G., Forzieri, G., Gosling, S., et al. (2020). *Global warming and drought impacts in the EU: JRC PESETA IV project. Task 7*. Publications Office. <https://doi.org/10.2760/597045>
- Castelletti, A., Pianosi, F., & Restelli, M. (2013). A multiobjective reinforcement learning approach to water resources systems operation: Pareto Frontier approximation in a single run. *Water Resources Research*, 49(6), 3476–3486. <https://doi.org/10.1002/wrcr.20295>
- CEDEX. (2016). *(Center for Studies and Experimentation of Public Works), Anuario de Aforos 2015–2016, Dirección General del Agua*. MAPAMA.
- CEDEX. (2017). *(Centro de Estudios Hidrográficos). Evaluación del Impacto del Cambio Climático en los Recursos Hídricos y Sequías en España. Informe final. Julio de 2017. Centro de Estudios Hidrográficos*. CEDEX.
- CHE. (2016). *(Confederación Hidrográfica del Ebro), Prospecto del Plan Hidrológico de la Demarcación Hidrográfica del Ebro*. MAPAMA, Zaragoza.
- CHE. (2022a). *(Confederación Hidrográfica del Ebro). Plan de Gestión del Riesgo de Inundación (2º Ciclo)*. Memoria. Confederación Hidrográfica del Ebro.
- CHE. (2022b). *(Confederación Hidrográfica del Ebro). Plan Hidrológico de la Demarcación Hidrográfica del Ebro Revisión de tercer ciclo (2022–2027). ANEJO 03 USOS Y DEMANDAS DE AGUA*. Retrieved from https://www.chebro.es/documents/2012/1027081/A03_PH3c_091_2023-01_A03_Demandas_v02.pdf/b8da98a5-7516-1b20-7207-5850c2e1d7c5?e=1675947131305
- Cheng, B., Li, H. E., Yue, S. Y., & Huang, K. (2019). A conceptual decision-making for the ecological base flow of rivers considering the economic value of ecosystem services of rivers in water shortage area of Northwest China. *Journal of Hydrology*, 578, 7. <https://doi.org/10.1016/j.jhydrol.2019.124126>
- Crespo, D., Albiac, J., Kahil, T., Esteban, E., & Baccour, S. (2019). Tradeoffs between water uses and environmental flows: A hydroeconomic analysis in the Ebro Basin. *Water Resources Management*, 33(7), 2301–2317. <https://doi.org/10.1007/s11269-019-02254-3>
- De Vos, L., Biemans, H., Doelman, J. C., Stehfest, E., & Van Vuuren, D. P. (2021). Trade-offs between water needs for food, utilities, and the environment—a nexus quantification at different scales. *Environmental Research Letters*, 16(11), 13. <https://doi.org/10.1088/1748-9326/ac2b5e>
- DGA. (2016). *(Gobierno de Aragón), Base de datos IT de superficies de cultivos por término municipal 2009*. Departamento de Desarrollo Rural y Sostenibilidad.
- Dinar, S., Katz, D., De Stefano, L., & Blankespoor, B. (2015). Climate change, conflict, and cooperation: Global analysis of the effectiveness of international river treaties in addressing water variability. *Political Geography*, 45, 55–66. <https://doi.org/10.1016/j.polgeo.2014.08.003>
- Espanmanesh, V., & Tilmant, A. (2022). Optimizing the management of multireservoir systems under shifting flow regimes. *Water Resources Research*, 58(6). <https://doi.org/10.1029/2021wr030582>
- Feyen, L., Gosling, S., Ciscar, J., Ibarreta, D., & Soria, A. (2020). Climate change impacts and adaptation in Europe. In *JRC PESETA IV final report*. Publications Office of the European Union. <https://doi.org/10.2760/171121>
- GC. (2016). *(Generalitat de Catalunya), Superficies Municipales dels Conreus Agrícoles, Any 2009. Departament d'Agricultura, Ramaderia, Pesca, Alimentació i Medi Natural*.
- Gil, J. D. B., Reidsma, P., Giller, K., Todman, L., Whitmore, A., & van Ittersum, M. (2019). Sustainable development goal 2: Improved targets and indicators for agriculture and food security. *Ambio*, 48(7), 685–698. <https://doi.org/10.1007/s13280-018-1101-4>
- Giuliani, M., & Castelletti, A. (2016). Is robustness really robust? How different definitions of robustness impact decision-making under climate change. *Climatic Change*, 135(3–4), 409–424. <https://doi.org/10.1007/s10584-015-1586-9>
- Giuliani, M., Herman, J. D., Castelletti, A., & Reed, P. (2014). Many-objective reservoir policy identification and refinement to reduce policy inertia and myopia in water management. *Water Resources Research*, 50(4), 3355–3377. <https://doi.org/10.1002/2013wr014700>
- Giuliani, M., Herman, J. D., Castelletti, A., & Reed, P. (2015). Many-objective reservoir policy identification and refinement to reduce policy inertia and myopia in water management. *Water Resources Research*, 50(4), 3355–3377. <https://doi.org/10.1002/2013wr014700>
- Giuliani, M., Lamontagne, J. R., Reed, P. M., & Castelletti, A. (2021). A state-of-the-art review of optimal reservoir control for managing conflicting demands in a changing world. *Water Resources Research*, 57(12). <https://doi.org/10.1029/2021wr029927>
- GN. (2016). *(Gobierno de Navarra), Base de datos IT de superficies de cultivos por término municipal 2009, Departamento de Desarrollo Rural*. Medio Ambiente y Administración Local.

- Goor, Q., Halleux, C., Mohamed, Y., & Tilmant, A. (2010). Optimal operation of a multipurpose multireservoir system in the eastern Nile River Basin. *Hydrology and Earth System Sciences*, 14(10), 1895–1908. <https://doi.org/10.5194/hess-14-1895-2010>
- Goor, Q., Kelman, R., & Tilmant, A. (2011). Optimal multipurpose-multireservoir operation model with variable productivity of hydropower plants. *Journal of Water Resources Planning and Management*, 137(3), 258–267. [https://doi.org/10.1061/\(asce\)wr.1943-5452.0000117](https://doi.org/10.1061/(asce)wr.1943-5452.0000117)
- Greve, P., Kahil, T., Mochizuki, J., Schinko, T., Satoh, Y., Burek, P., et al. (2018). Global assessment of water challenges under uncertainty in water scarcity projections. *Nature Sustainability*, 1(9), 486–494. <https://doi.org/10.1038/s41893-018-0134-9>
- Grey, D., & Sadoff, C. (2007). Sink or swim? Water security for growth and development. *Water Policy*, 9(6), 545–571. <https://doi.org/10.2166/wp.2007.021>
- Hernández, N., Gil, M., Garrido, A., & Rodríguez, R. (2013). *La sequía 2005-2008 en la Cuenca del Ebro: Vulnerabilidad, impactos y medidas de gestión*. UPM-CEIGRAM.
- Hurford, A. P., Huskova, I., & Harou, J. J. (2014). Using many-objective trade-off analysis to help dams promote economic development, protect the poor and enhance ecological health. *Environmental Science & Policy*, 38, 72–86. <https://doi.org/10.1016/j.envsci.2013.10.003>
- Jalilov, S. M., Amer, S. A., & Ward, F. A. (2018). Managing the water-energy-food nexus: Opportunities in central Asia. *Journal of Hydrology*, 557, 407–425. <https://doi.org/10.1016/j.jhydrol.2017.12.040>
- Jalilov, S. M., Keskinen, M., Varis, O., Amer, S., & Ward, F. A. (2016). Managing the water-energy-food nexus: Gains and losses from new water development in Amu Darya River Basin. *Journal of Hydrology*, 539, 648–661. <https://doi.org/10.1016/j.jhydrol.2016.05.071>
- Koutsoyiannis, D., & Economou, A. (2003). Evaluation of the parameterization-simulation-optimization approach for the control of reservoir systems. *Water Resources Research*, 39(6), 17. <https://doi.org/10.1029/2003wr002148>
- Kuang, D., & Liao, K. H. (2020). Learning from Floods: Linking flood experience and flood resilience. *Journal of Environmental Management*, 271, 11. <https://doi.org/10.1016/j.jenvman.2020.11.1025>
- Libisch-Lehner, C. P., Nguyen, H. T. T., Taormina, R., Nachtnebel, H. P., & Galelli, S. (2019). On the value of ENSO state for urban water supply system operators: Opportunities, trade-offs, and challenges. *Water Resources Research*, 55(4), 2856–2875. <https://doi.org/10.1029/2018wr023622>
- Lines, C., Werner, M., & Bastiaanssen, W. (2017). The predictability of reported drought events and impacts in the Ebro Basin using six different remote sensing data sets. *Hydrology and Earth System Sciences*, 21(9), 4747–4765. <https://doi.org/10.5194/hess-21-4747-2017>
- Lopez-Moreno, J. I., Zabalza, J., Vicente-Serrano, S. M., Revuelto, J., Gilaberte, M., Azorin-Molina, C., et al. (2014). Impact of climate and land use change on water availability and reservoir management: Scenarios in the Upper Aragon River, Spanish Pyrenees. *Science of the Total Environment*, 493, 1222–1231. <https://doi.org/10.1016/j.scitotenv.2013.09.031>
- MAPAMA. (2021). *Ministerio de Agricultura y Pesca, Alimentación y Medio Ambiente, Anuario de Estadística 2016–2021*. MAPAMA.
- Marques, G. F., & Tilmant, A. (2013). The economic value of coordination in large-scale multireservoir systems: The Parana River case. *Water Resources Research*, 49(11), 7546–7557. <https://doi.org/10.1002/2013wr013679>
- MITECO. (2020). *(Ministerio para la Transición Ecológica). Plan Nacional Integrado de Energía y Clima 2021–2030*. MITECO.
- MITECO. (2022). *(Ministerio para la Transición Ecológica). Plan Más Seguridad Energética*. MITECO.
- Pereira, M., & Pinto, L. (1983). Application of decomposition techniques to the mid-and short-term scheduling of hydrothermal systems. *IEEE Transactions on Power Apparatus and Systems*, PAS-102(11), 3611–3618. <https://doi.org/10.1109/tpas.1983.317709>
- Pereira, M., & Pinto, L. (1991). Multi-stage stochastic optimization applied to energy planning. *Mathematical Programming*, 52(1–3), 359–375. <https://doi.org/10.1007/bf01582895>
- Peters, J., & Schaal, S. (2008). Reinforcement learning of motor skills with policy gradients. *Neural Networks*, 21(4), 682–697. <https://doi.org/10.1016/j.neunet.2008.02.003>
- Pina, J., Tilmant, A., & Cote, P. (2017). Optimizing multireservoir system operating policies using exogenous hydrologic variables. *Water Resources Research*, 53(11), 9845–9859. <https://doi.org/10.1002/2017wr021701>
- Poff, N. L., Brown, C. M., Grantham, T., Matthews, J. H., Palmer, M. A., Spence, C. M., et al. (2016). Sustainable water management under future uncertainty with eco-engineering decision scaling. *Nature Climate Change*, 6(1), 25–34. <https://doi.org/10.1038/nclimate2765>
- Pulido-Velazquez, D., Collados-Lara, A. J., Perez-Sanchez, J., Segura-Mendez, F. J., & Senent-Aparicio, J. (2021). Climate change impacts on the streamflow in Spanish basins monitored under near-natural conditions. *Journal of Hydrology-Regional Studies*, 38, 21. <https://doi.org/10.1016/j.ejrh.2021.100937>
- Quinn, J. D., Reed, P. M., Giuliani, M., & Castelletti, A. (2017). Rival framings: A framework for discovering how problem formulation uncertainties shape risk management trade-offs in water resources systems. *Water Resources Research*, 53(8), 7208–7233. <https://doi.org/10.1002/2017wr020524>
- Rosenstein, M., & Barto, A. (2001). Robot weightlifting by direct policy search. In *International joint conference on artificial intelligence* (Vol. 17, pp. 839–846). Citeseer.
- Sant'Anna, C., Tilmant, A., & Pulido-Velazquez, M. (2022). A hydrologically-driven approach to climate change adaptation for multipurpose multireservoir systems. *Climate Risk Management*, 36, 16.
- Schmidt, N. D. V., Wilson, T. S., Flint, L. E., & Langridge, R. (2023). Trade-offs in adapting to changes in climate, land use, and water availability in California. *Ecology and Society*, 28(4), 61.
- Sehnke, F., Osendorfer, C., Rückstieß, T., Graves, A., Peters, J., & Schmidhuber, J. (2010). Parameter-exploring policy gradients. *Neural Networks*, 23(4), 551–559. <https://doi.org/10.1016/j.neunet.2009.12.004>
- Smith, R., Valencia, D., & Cadavid, E. (2013). Probabilistic trade-off curves for multipurpose reservoir operation in Colombia. In *Stochastic and statistical methods in hydrology and environmental engineering: Effective environmental management for sustainable development* (pp. 281–291). Springer.
- Tejada-Guibert, J. A., Johnson, S. A., & Stedinger, J. R. (1993). Comparison of two approaches for implementing multireservoir operating policies derived using stochastic dynamic programming. *Water Resources Research*, 29(12), 3969–3980. <https://doi.org/10.1029/93wr02277>
- Tilmant, A., & Kelman, R. (2007). A stochastic approach to analyze trade-offs and risks associated with large-scale water resources systems. *Water Resources Research*, 43(6), 11. <https://doi.org/10.1029/2006wr005094>
- Tilmant, A., Pina, J., Salman, M., Casarotto, C., Ledbi, F., & Pek, E. (2020). Probabilistic trade-off assessment between competing and vulnerable water users - the case of the Senegal River basin. *Journal of Hydrology*, 587, 15. <https://doi.org/10.1016/j.jhydrol.2020.124915>
- Tilmant, A., Pinte, D., & Goor, Q. (2008). Assessing marginal water values in multipurpose multireservoir systems via stochastic programming. *Water Resources Research*, 44(12), 17. <https://doi.org/10.1029/2008wr007024>
- Torhan, S., Grady, C. A., Ajibade, I., Galappaththi, E. K., Hernandez, R. R., Musah-Surugu, J. I., et al. (2022). Tradeoffs and synergies across global climate change adaptations in the food-energy-water nexus. *Earth's Future*, 10(4), 15. <https://doi.org/10.1029/2021ef002201>

- Turner, B. L., Kasperson, R. E., Matson, P. A., McCarthy, J. J., Corell, R. W., Christensen, L., et al. (2003). A framework for vulnerability analysis in sustainability science. *Proceedings of the National Academy of Sciences of the United States of America*, *100*(14), 8074–8079. <https://doi.org/10.1073/pnas.1231335100>
- UN. (2018). (United Nations), High level political forum goals in focus: Goal 6: Ensure availability and sustainable management of water and sanitation for all. *United Nations Statistics Division (UNSD), a division of the Department of Economic and Social Affairs (DESA)*. Retrieved from <https://unstats.un.org/sdgs/report/2018/goal-06/>
- Valipour, E., Ketabchi, H., Shali, R., & Morid, S. (2024). Water resources allocation: Interactions between equity/justice and allocation strategies. *Water Resources Management*, *38*(2), 505–535. <https://doi.org/10.1007/s11269-023-03682-y>
- Vargas, J., & Paneque, P. (2017). Methodology for the analysis of causes of drought vulnerability on the River Basin scale. *Natural Hazards*, *89*(2), 609–621. <https://doi.org/10.1007/s11069-017-2982-4>
- Vorosmarty, C. J., McIntyre, P. B., Gessner, M. O., Dudgeon, D., Prusevich, A., Green, P., et al. (2010). Global threats to human water security and river biodiversity. *Nature*, *467*(7315), 555–561. <https://doi.org/10.1038/nature09440>
- Whiteson, S., & Stone, P. (2006). Evolutionary function approximation for reinforcement learning. *Journal of Machine Learning Research*, *7*, 877–917.
- Whitley, D., Dominic, S., Das, R., & Anderson, C. W. (1993). Genetic reinforcement learning for Neurocontrol problems. *Machine Learning*, *13*(2–3), 259–284. <https://doi.org/10.1007/bf00993045>
- Wilson, E. (2019). What is benefit sharing? Respecting indigenous rights and addressing inequities in arctic resource projects. *Resources-Basel*, *8*(2), 23. <https://doi.org/10.3390/resources8020074>
- Wu, J. Y., Luo, J. A., Du, X. Z., Zhang, H., & Qin, S. (2022). Optimizing water allocation in an inter-basin water diversion project with equity-efficiency tradeoff: A bi-level multiobjective programming model under uncertainty. *Journal of Cleaner Production*, *371*, 13. <https://doi.org/10.1016/j.jclepro.2022.133606>
- Wu, L. N., Elshorbagy, A., Pande, S., & Zhuo, L. (2021). Trade-offs and synergies in the water-energy-food nexus: The case of Saskatchewan, Canada. *Resources, Conservation and Recycling*, *164*, 14. <https://doi.org/10.1016/j.resconrec.2020.105192>
- Zhang, X., Tian, Y., Dong, N., Wu, H., & Li, S. (2023). The projected futures of water resources vulnerability under climate and socioeconomic change in the Yangtze River Basin, China. *Ecological Indicators*, *147*, 109933. <https://doi.org/10.1016/j.ecolind.2023.109933>