

# Design of the Feet and the Sidebar for a Height Adjustable Table

***Beatriz Talabante Clavería***  
***Final Project Work 2009***  
***Industrial Design***

Planning	3
Brief	4
Information	5
Sketches: 1 <sup>st</sup> Ideas	18
1 <sup>st</sup> meeting. Conclusions	32
Modeling in Autodesk Inventor 10	33
Tension Analysis	41
2 <sup>nd</sup> Meeting. Conclusions	42
Sapa Profiler AB	43
Development	44
Inspired by ROL's feet	45
Arc Feet	49
Tubular Feet	56
Appendix	63



W	MONDAY	TUESDAY	WEDNESDAY	THURSDAY	FRIDAY	SATURDAY	SUNDAY
40	28 SEPT	29	30	1 OCT	2	3	4
DRAWING BY							
41	5	6	7	8 1 <sup>ST</sup> MEETING	9	10	11
HAND							
42	12	13	14	15	16	17	18
MODELING IN							
43	19	20	21	22	23 MEETING WITH DAG	24	25
INVENTOR 10							
44	26	27	28 13:00 JTH MEETING WITH DAG RAUDBERGET	29	30	31	1 NOV
45	2	3	4	5 PROTOTYPES FROM JTH	6	7	8
DEVELOPMENT							
46	9	10	11	12	13	14	15
47	16	17	18	19 VISIT TO SAPA	20	21	22
PROTOTYPE							
48	23	24	25	26	27	28	29
WRITE THE PROJECT							
49	30	1 DIC	2	3	4	5	6
50	7	8	9	10	11 MEETING WITH DAG	12	13
51	14	15	16	17	18 PROJECT PRESENTATION	19	20

## FINAL PROJECT WORK Sept-Dec 2009

### *Design of the feet and the sidebars for a height-adjustable table.*

Rol Ergo AB & Jönköping University.

#### *Project Description:*

The project involves the design of the feet and the sidebar for a height adjustable table.

Rol Ergo AB works with steel, but they accept other materials such as aluminum or plastic components.

The assembly with other components (adjustable legs) has to be easy to reduce the manufacturing time.

Rol Ergo AB wants to develop a new design for adjustable legs, which would be different from what they currently have.

In the initial design phase, there are no limits. Any shape, material or added function is valid. At later stages, limits will be set.

## *Information*



## Stand ED 500 Rect

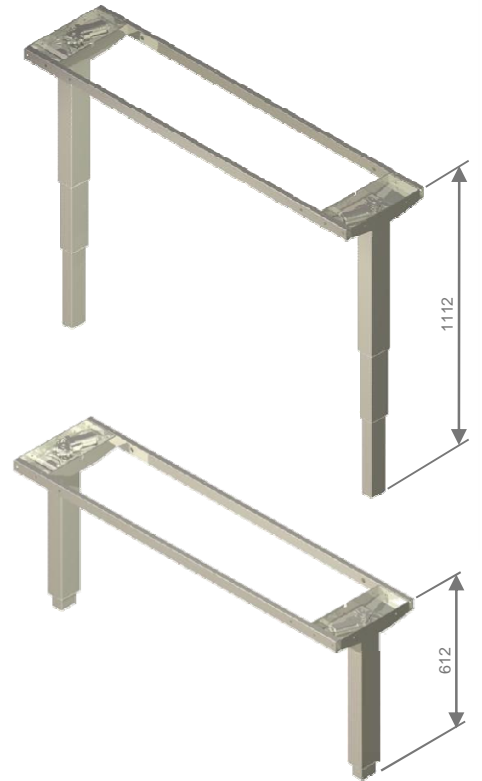

## Stand ED 650 Rect

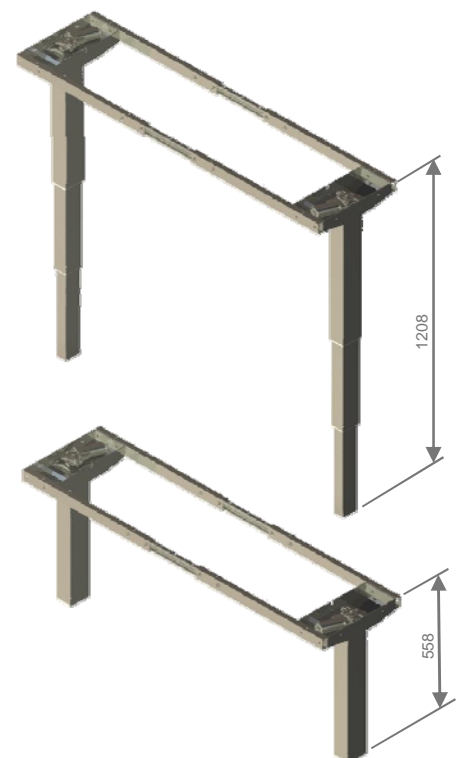

## Stand ED 500 Round



POSITION 1 - WASHER

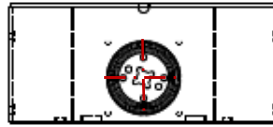

POSITION 2 - WASHER

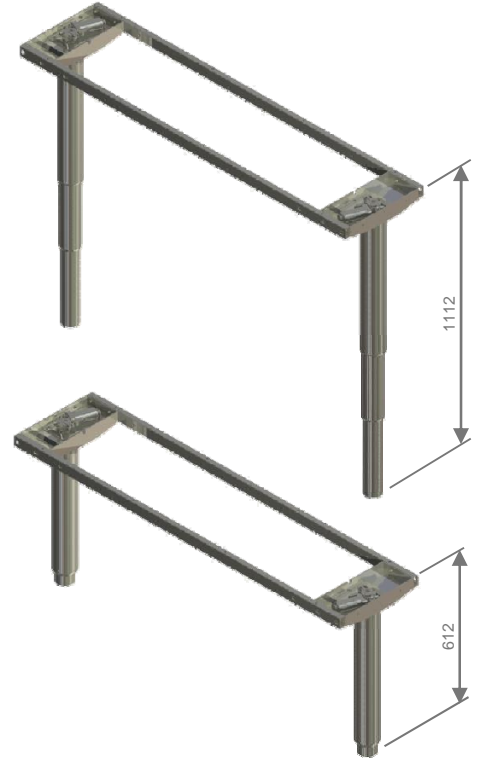
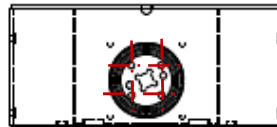

## Stand ED 650 Round



POSITION 1 - WASHER

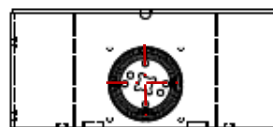

POSITION 2 - WASHER

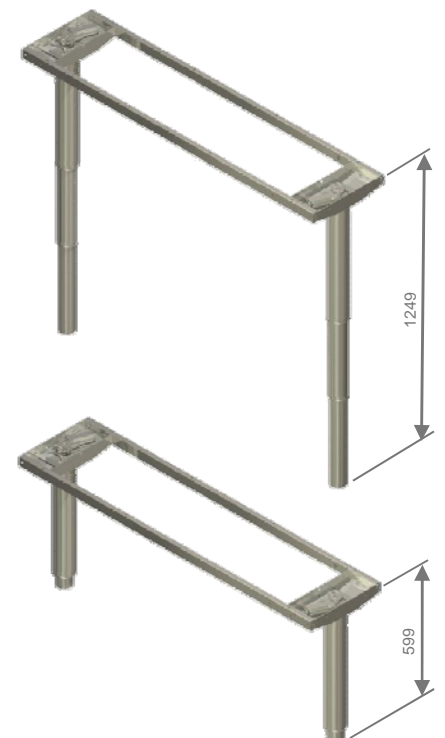
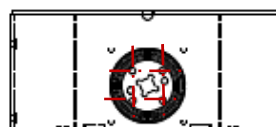



## Stand ED USD 650 Rect

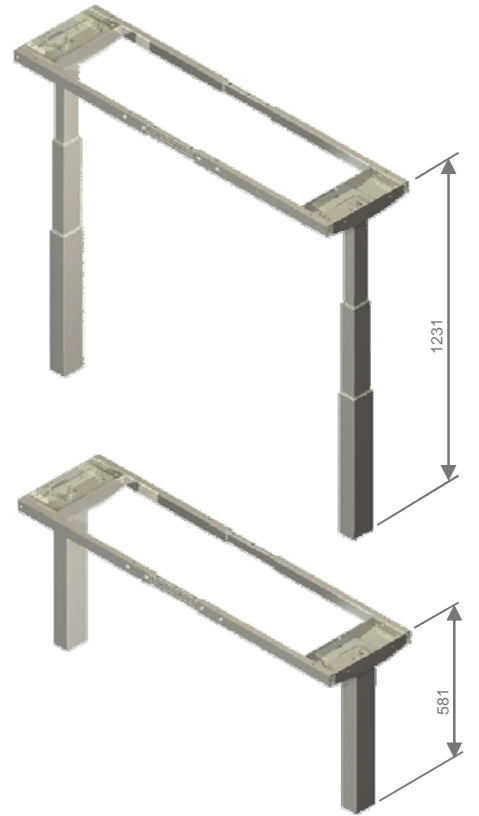

## Stand 470 Rect

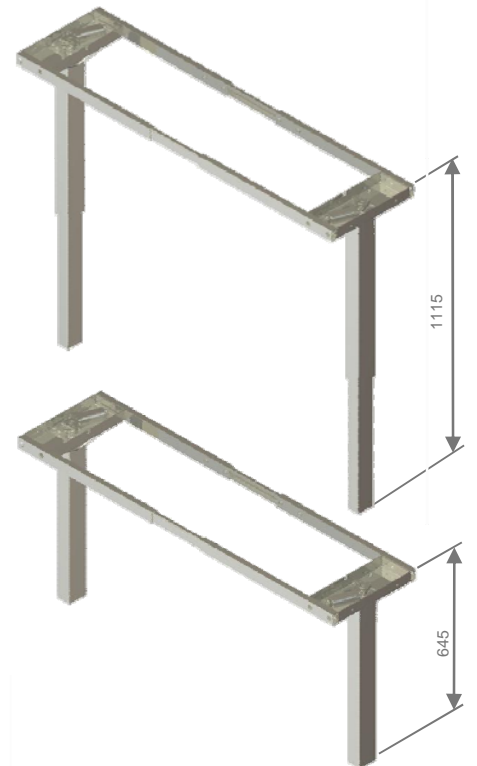

## Stand SingleDrive 470 Rect

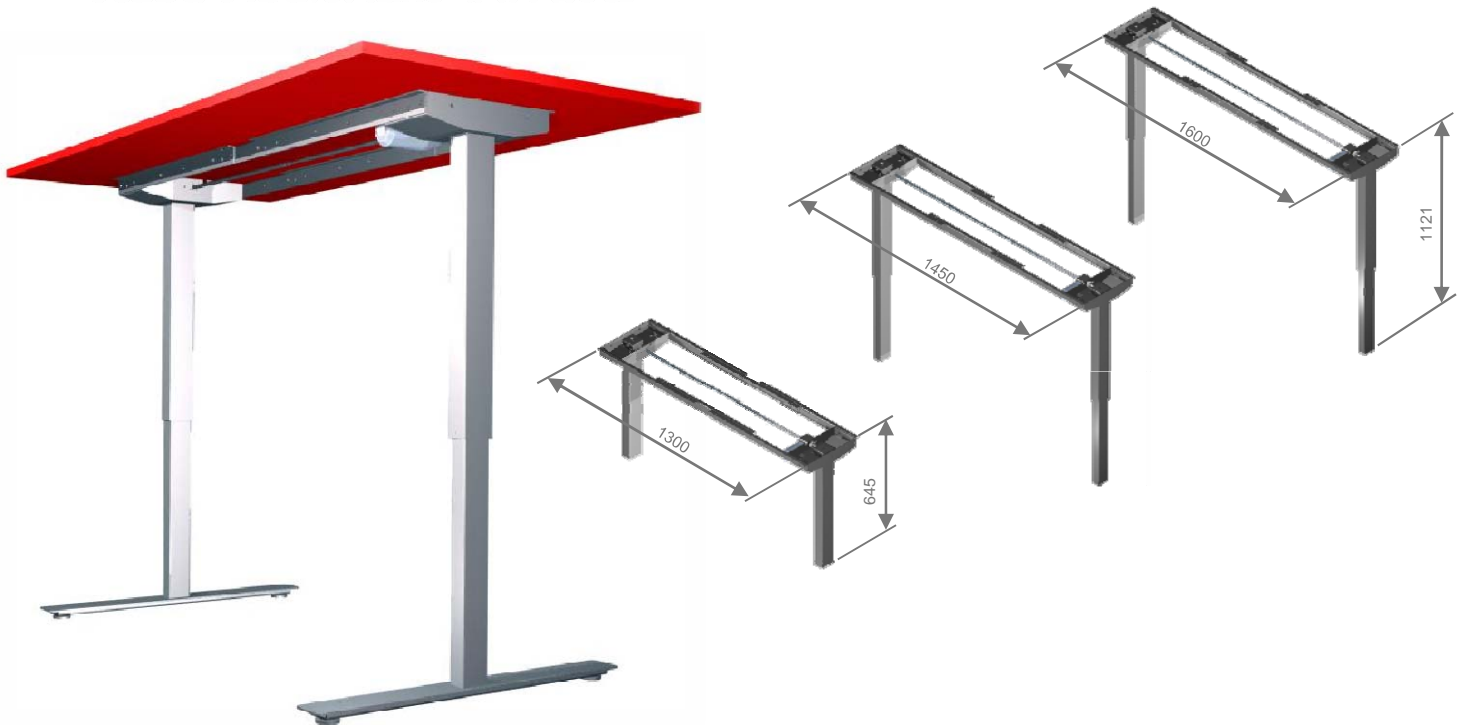

## Stand ED Crank Round

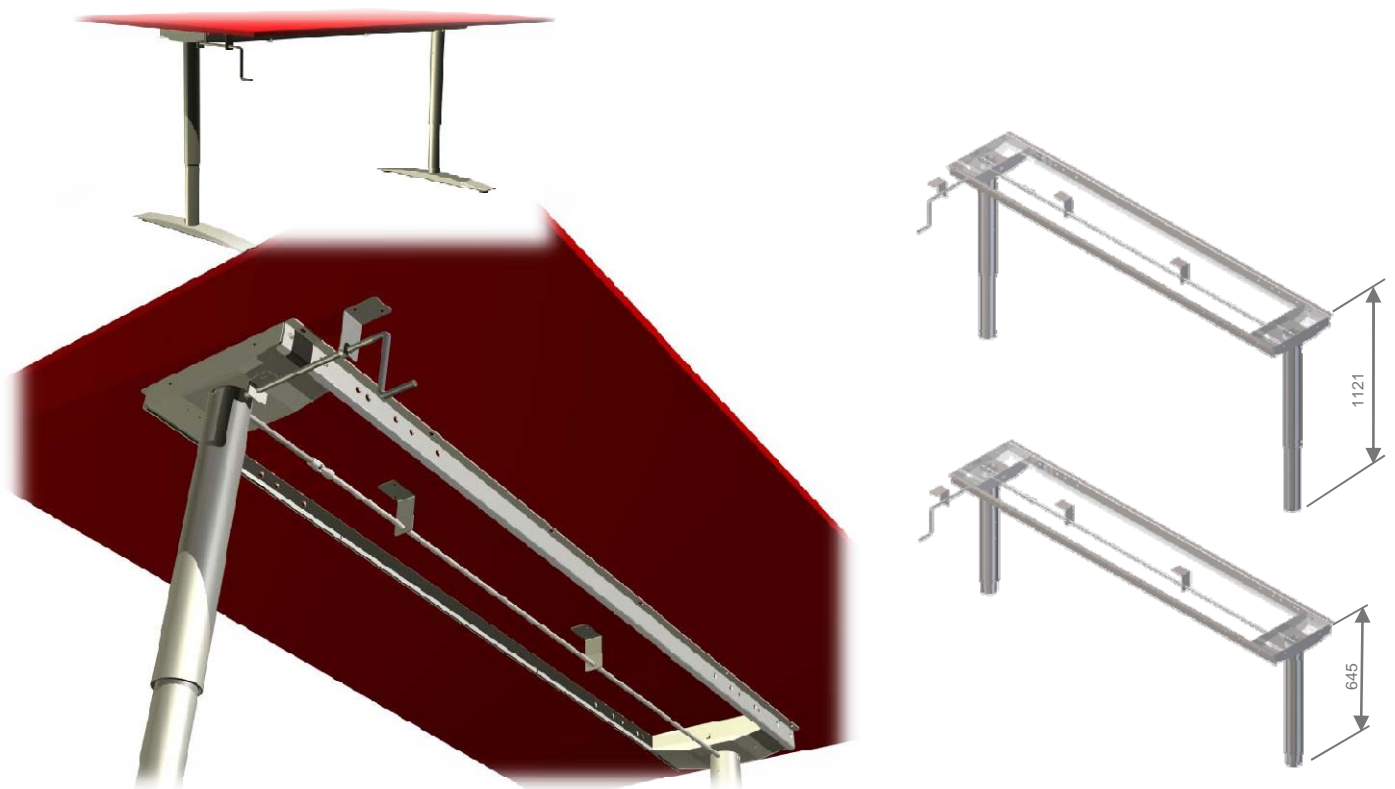



## Stand ED Fixed Rect



## Stand ED Screw 230 Round



## Stand ED Screw 200 Rect

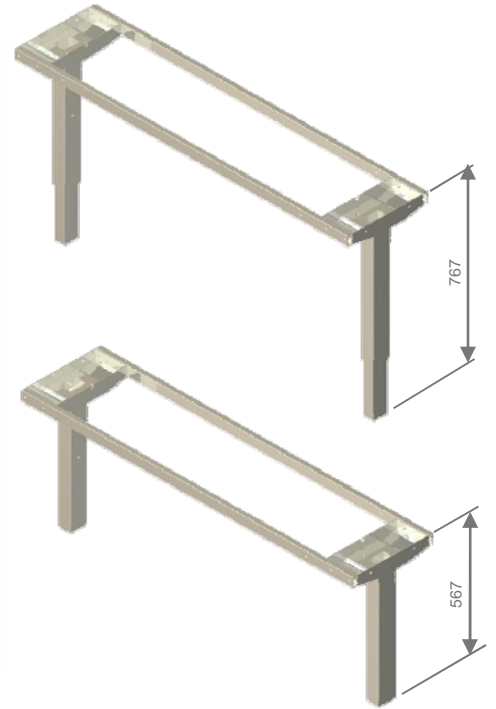

## Stand DM Sync 600 Round

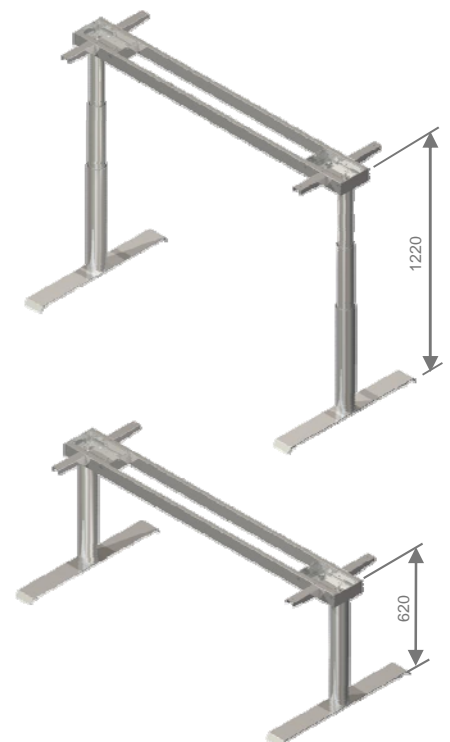

## Frames

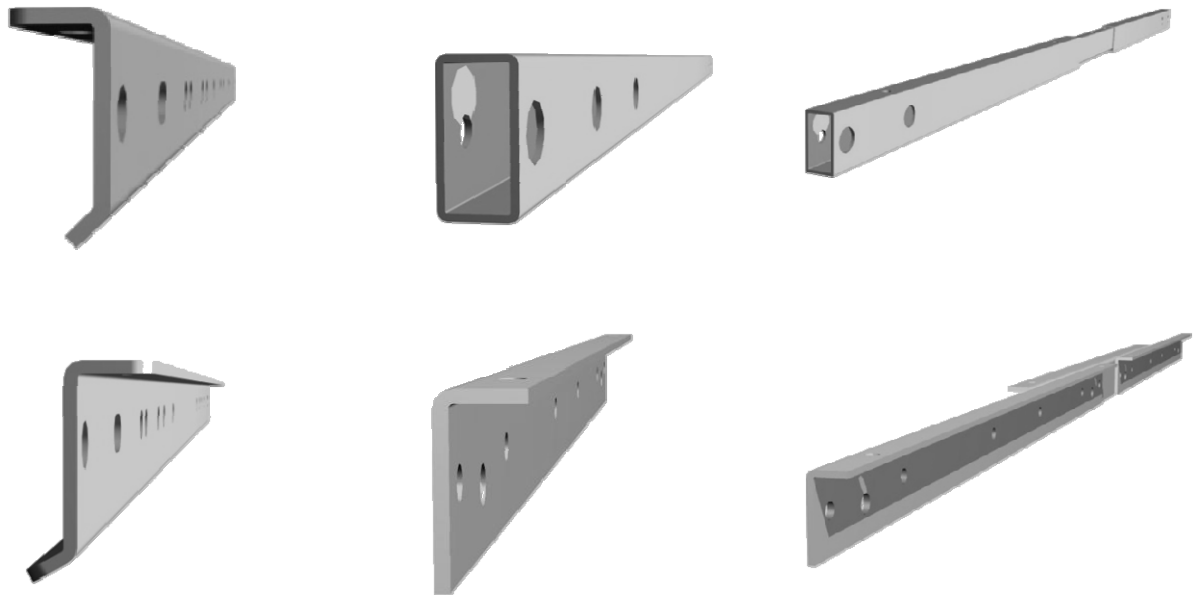

## Sidebar



## Sidebar Adjustable Table Top

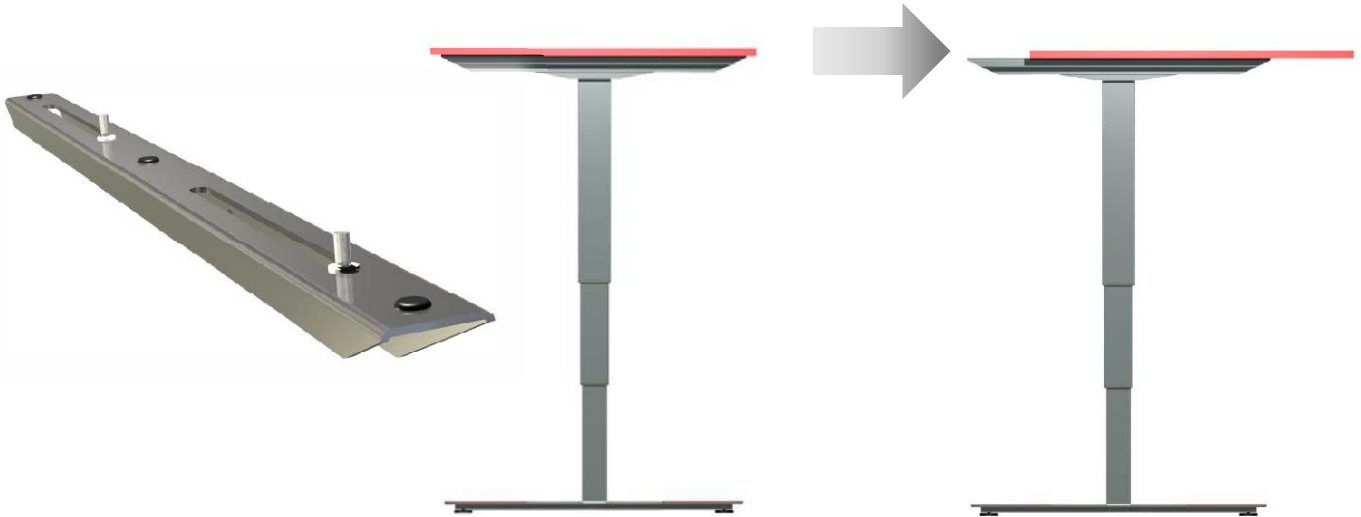

## Bracket Boarder

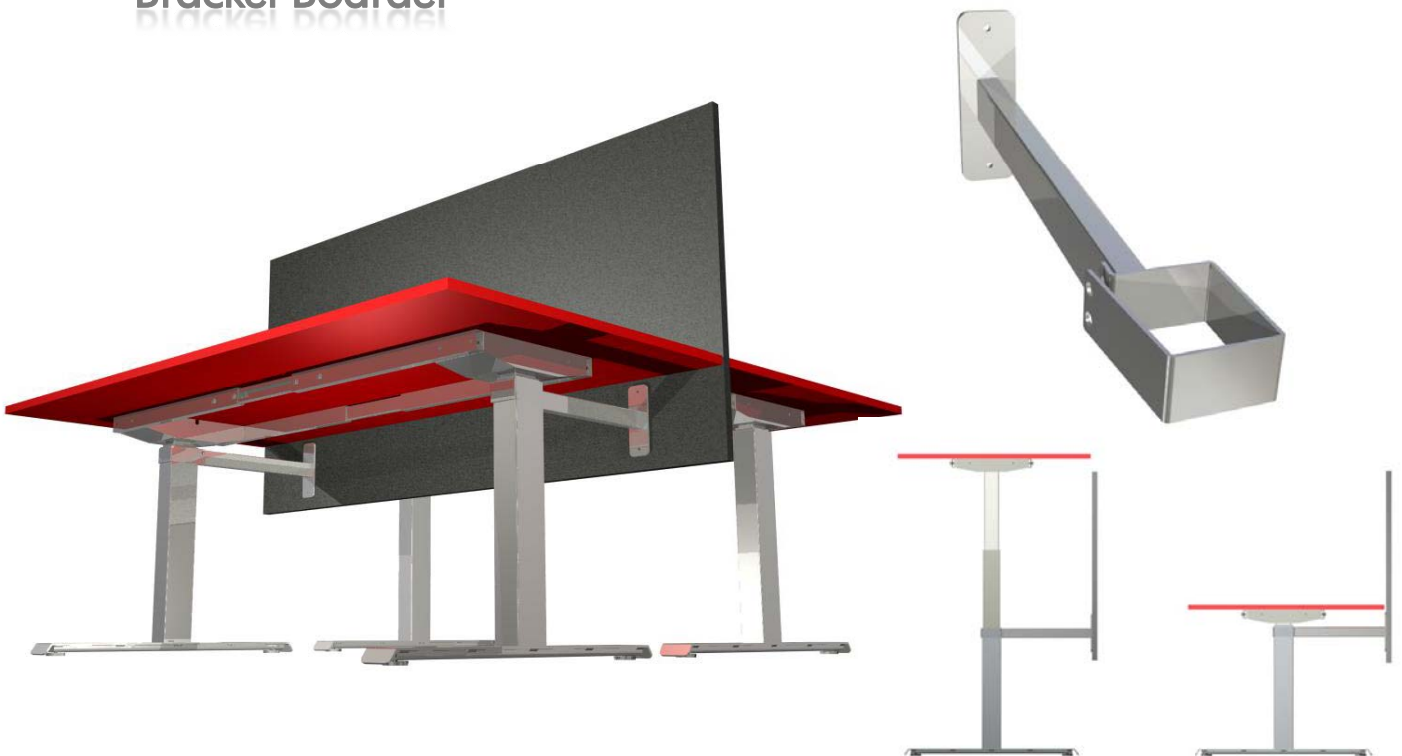

Sidebar Adjustable Table Top Bracket Boarder

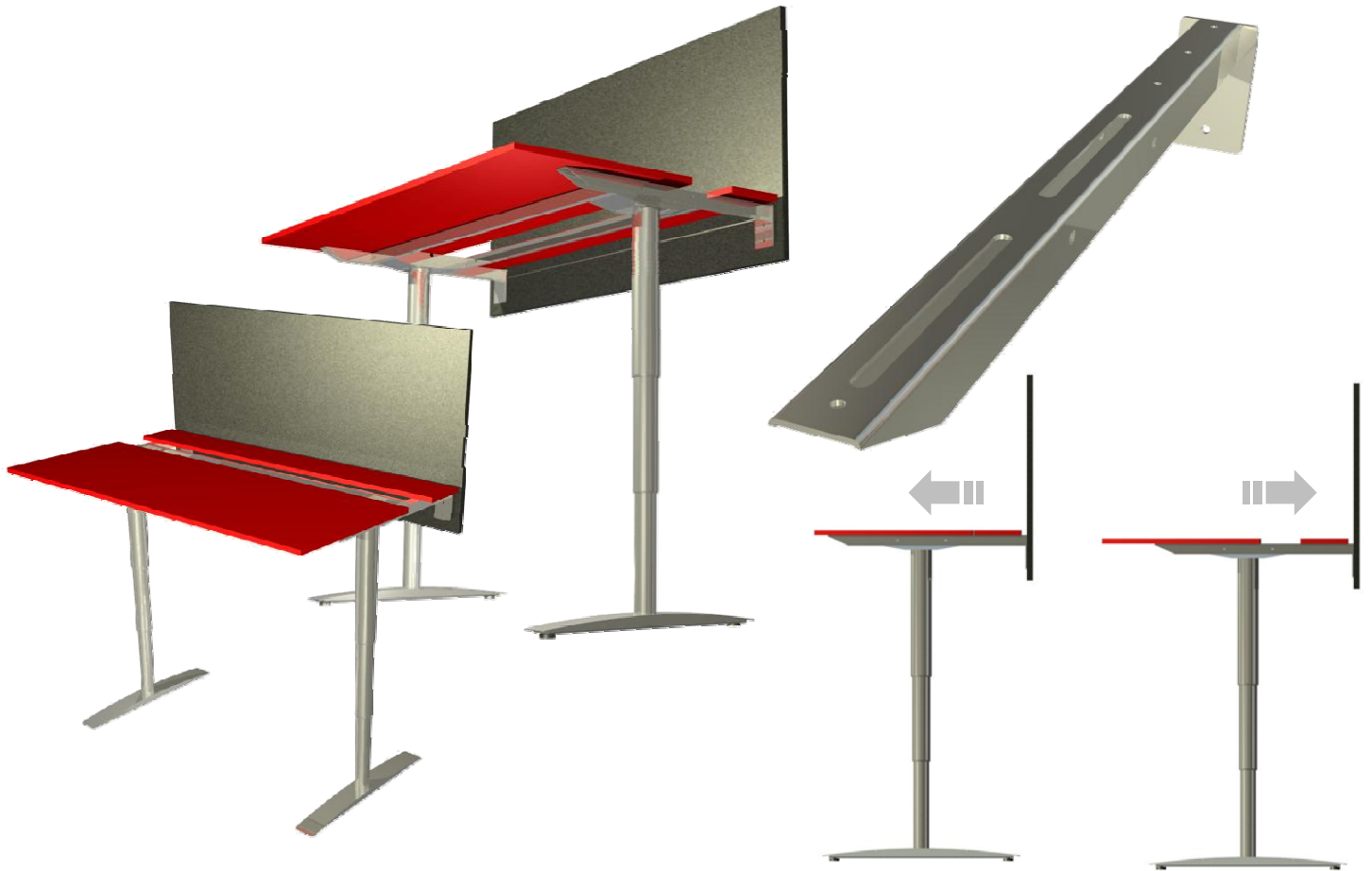

CPU



Control Box

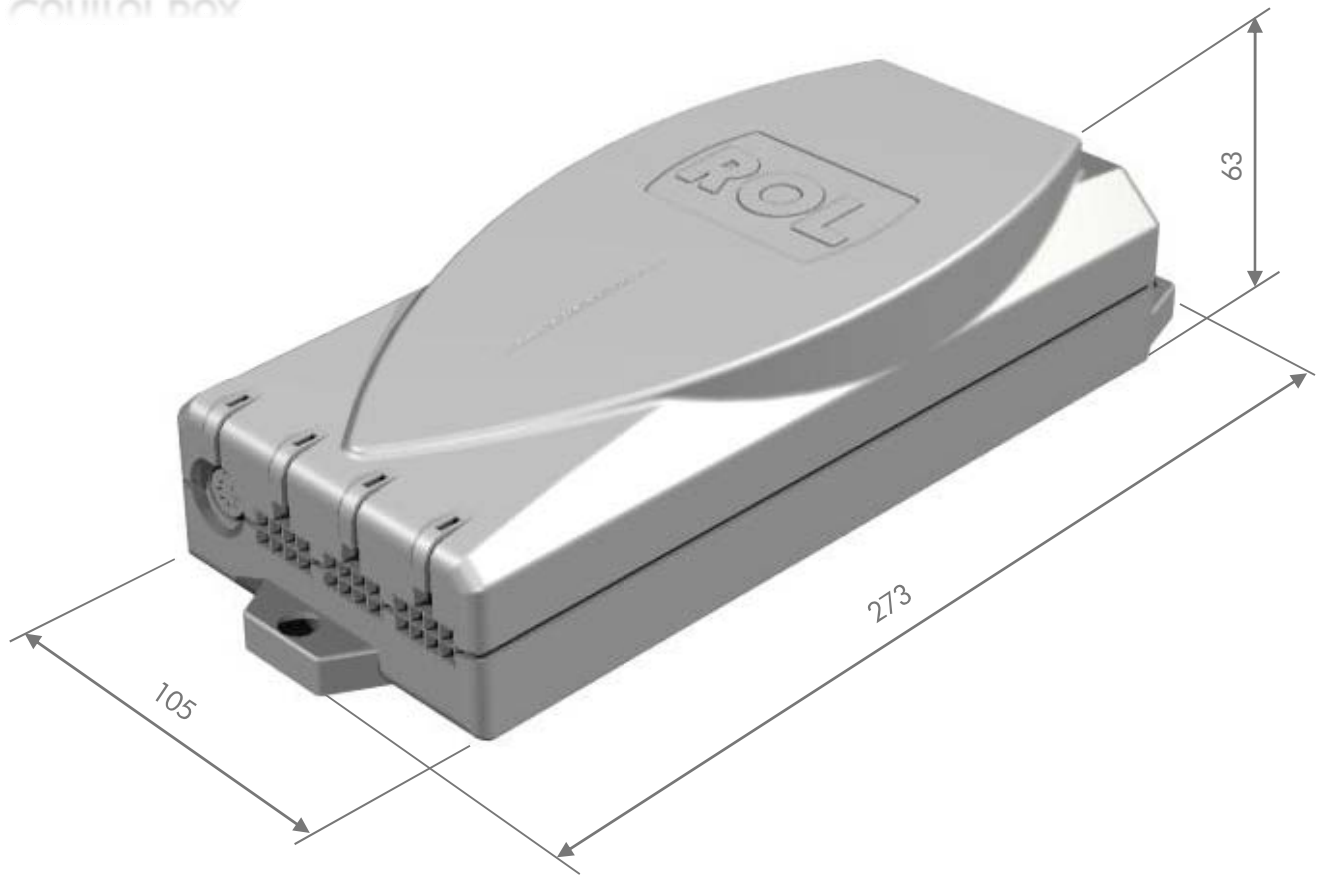

Engine

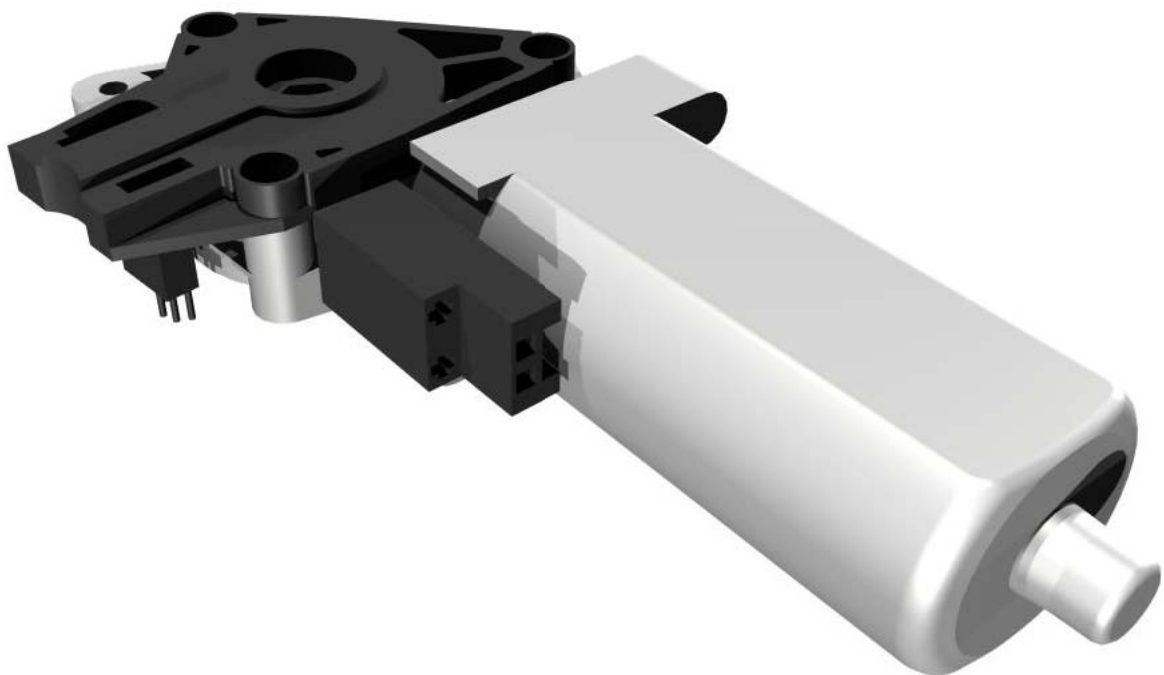



Display



Cable connection

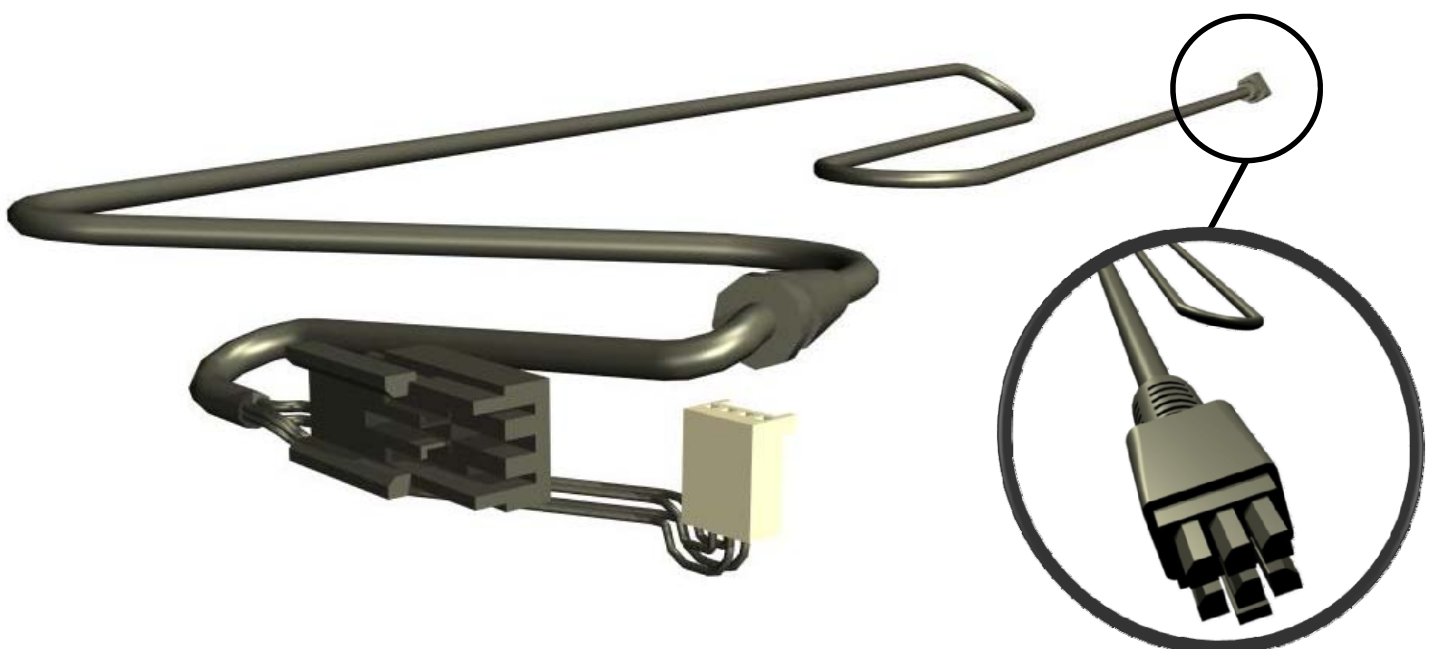



## Feet for Rectangular Legs

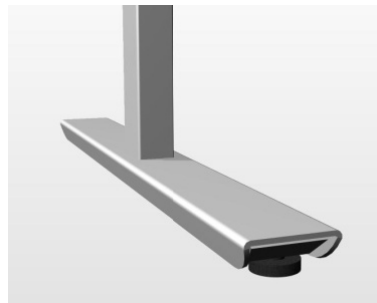
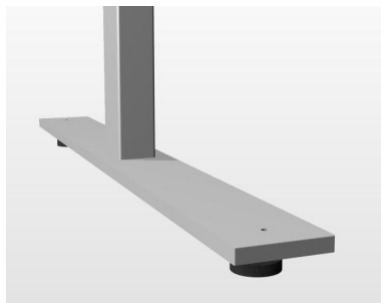
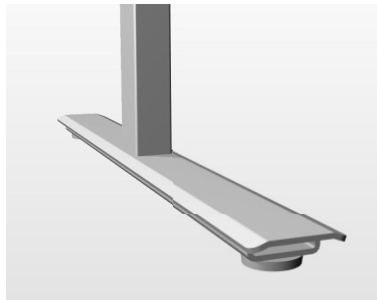
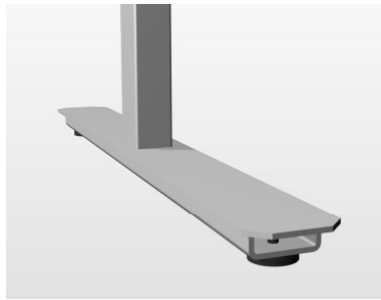

## Feet for Round Legs



## *Sketches: 1<sup>st</sup> Ideas*

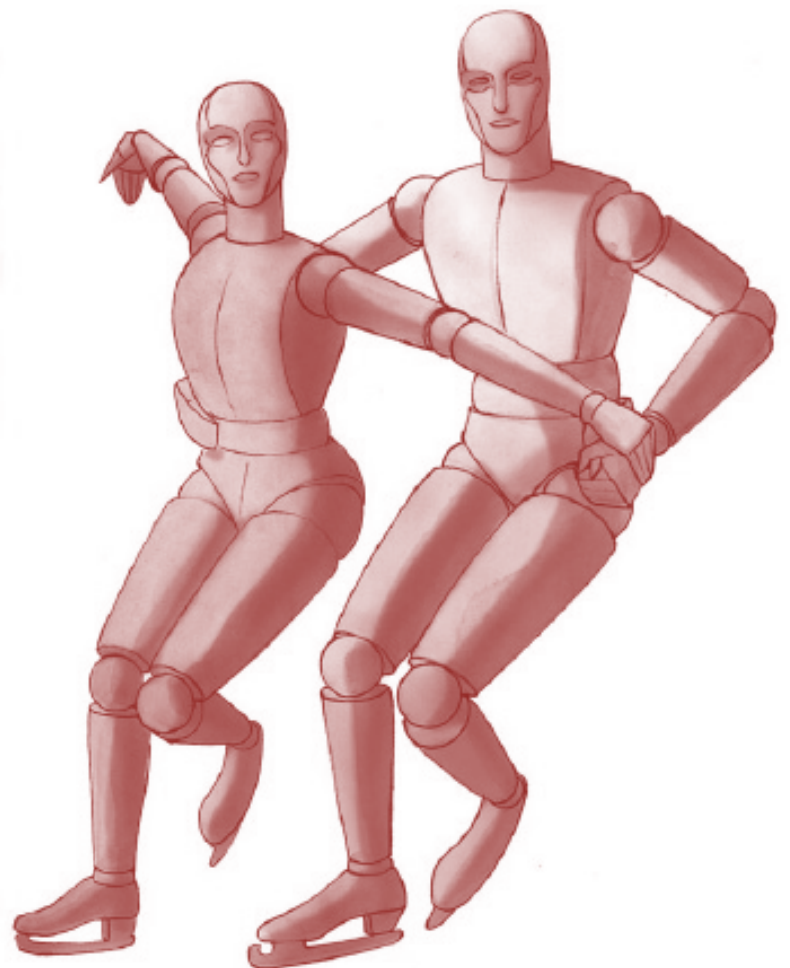

# Sketches Group I: Inspired by Rol's feet

This foot follows Rol's feet shapes.

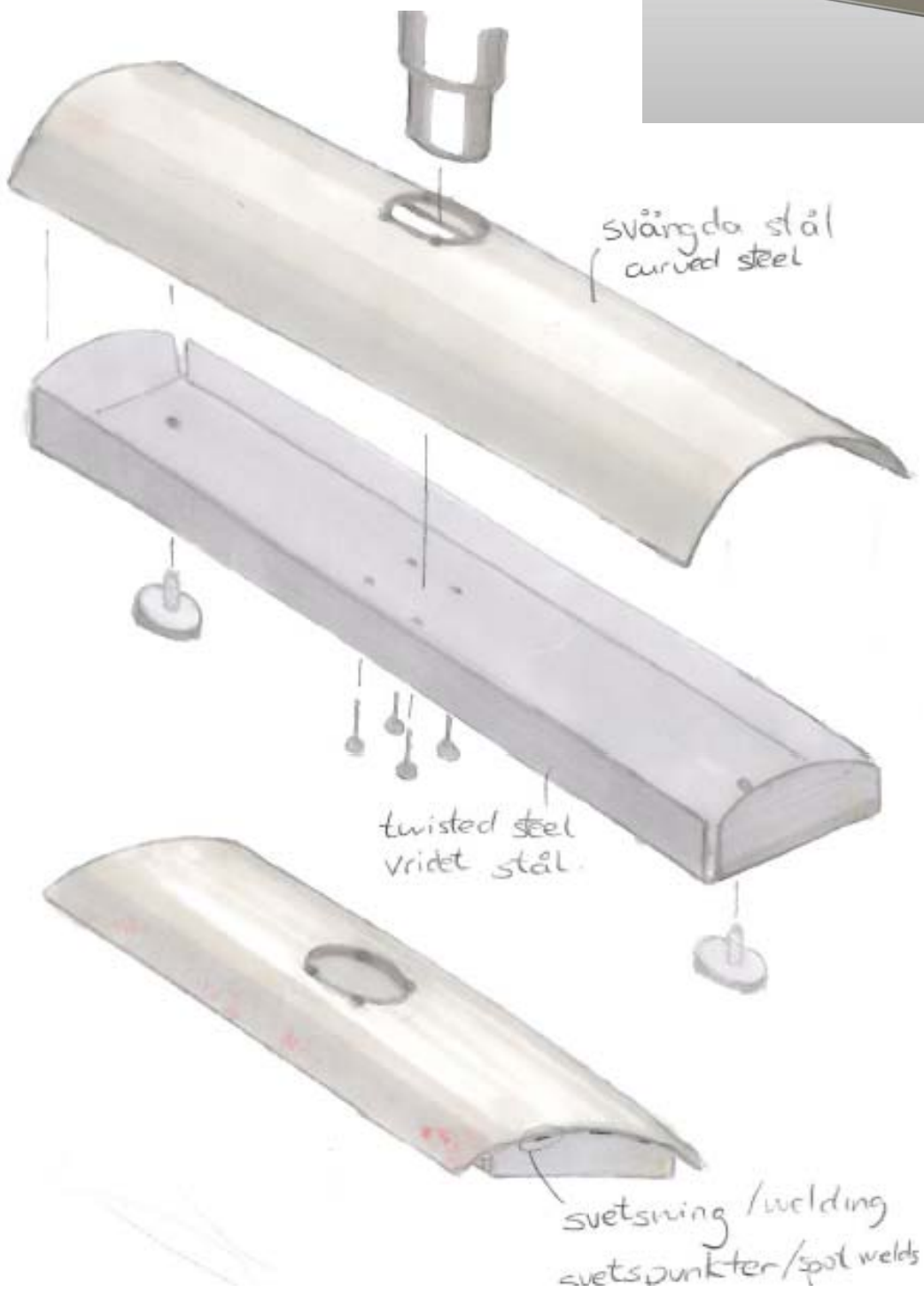

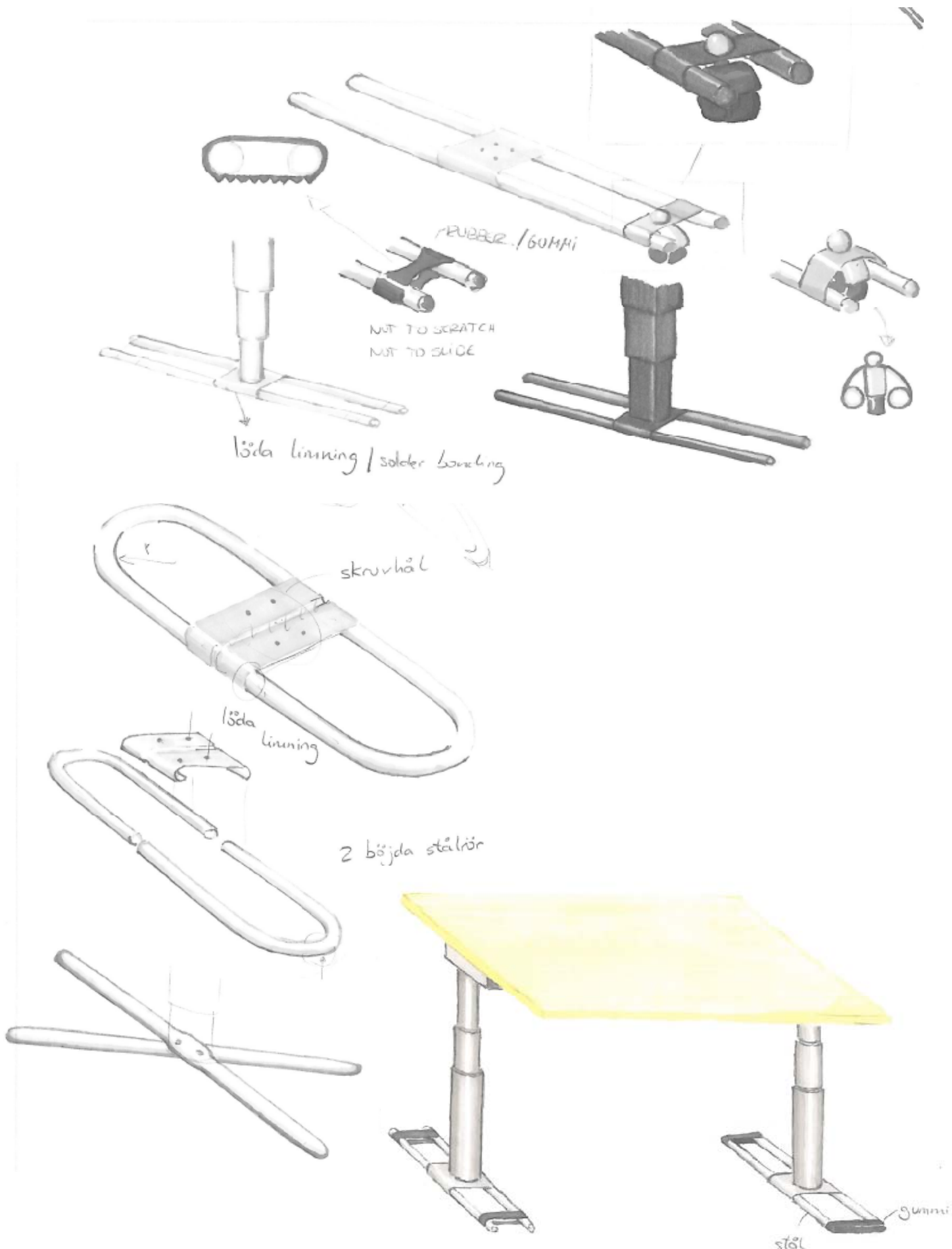

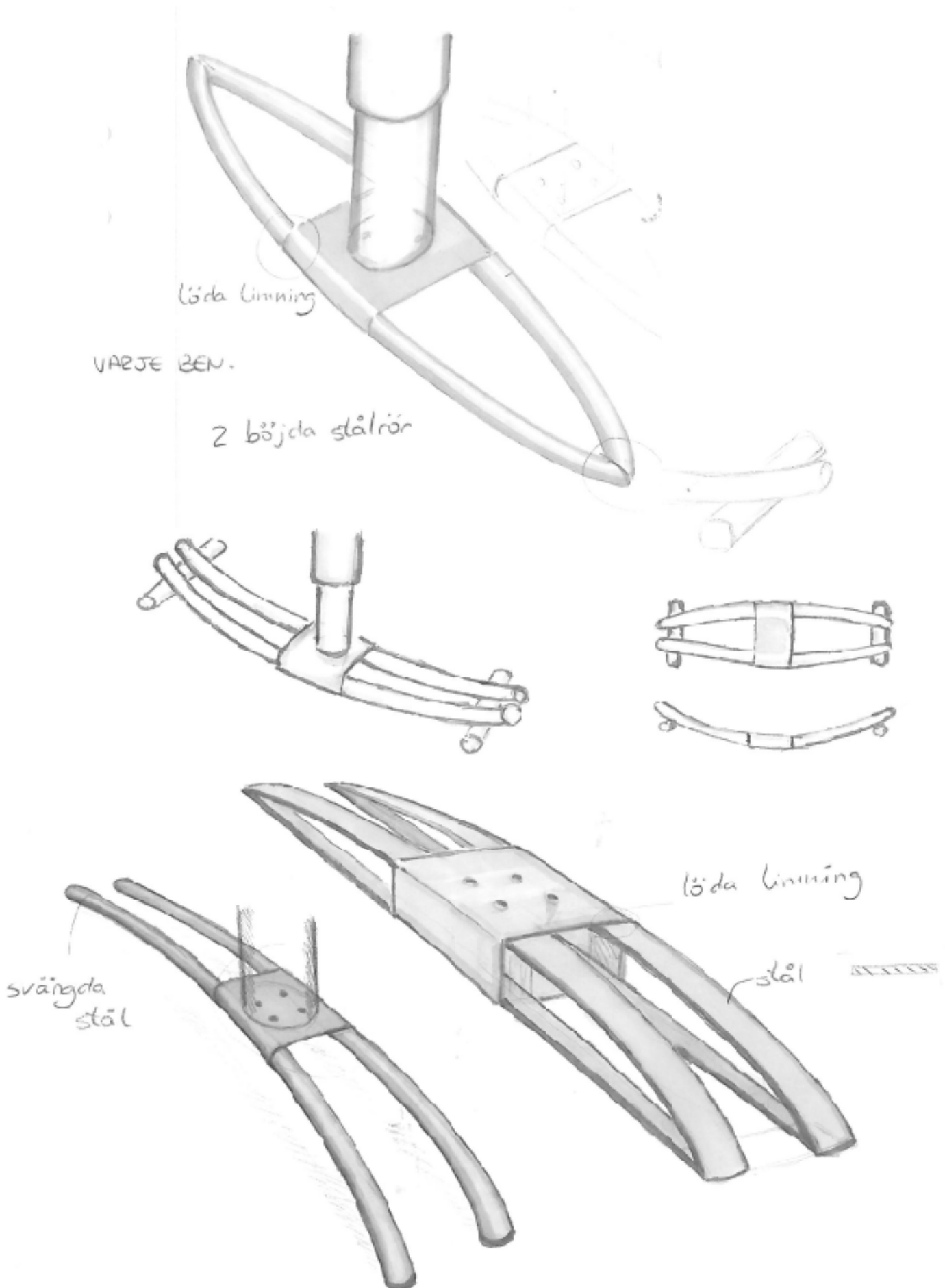

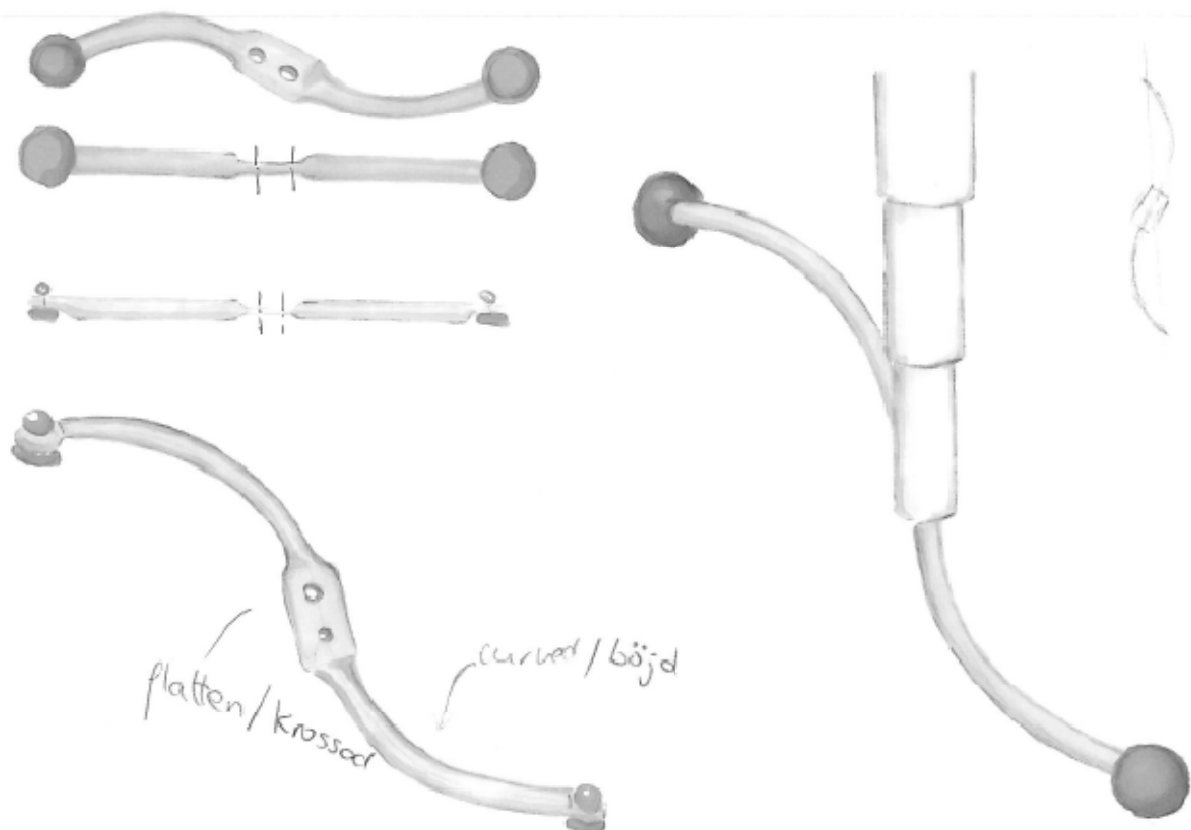
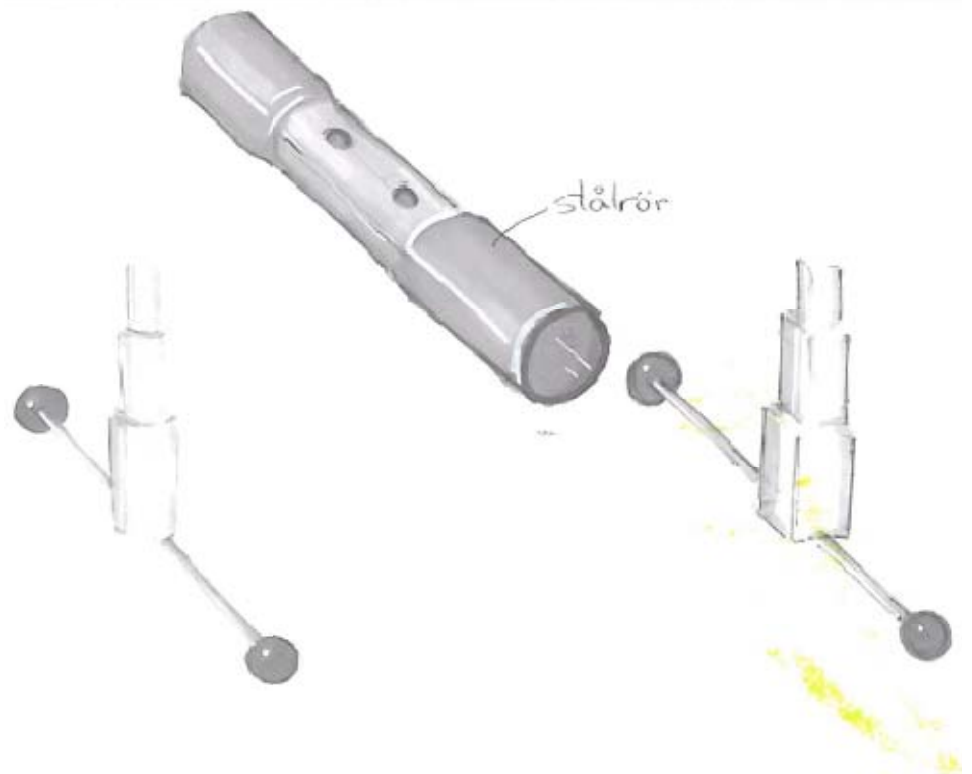

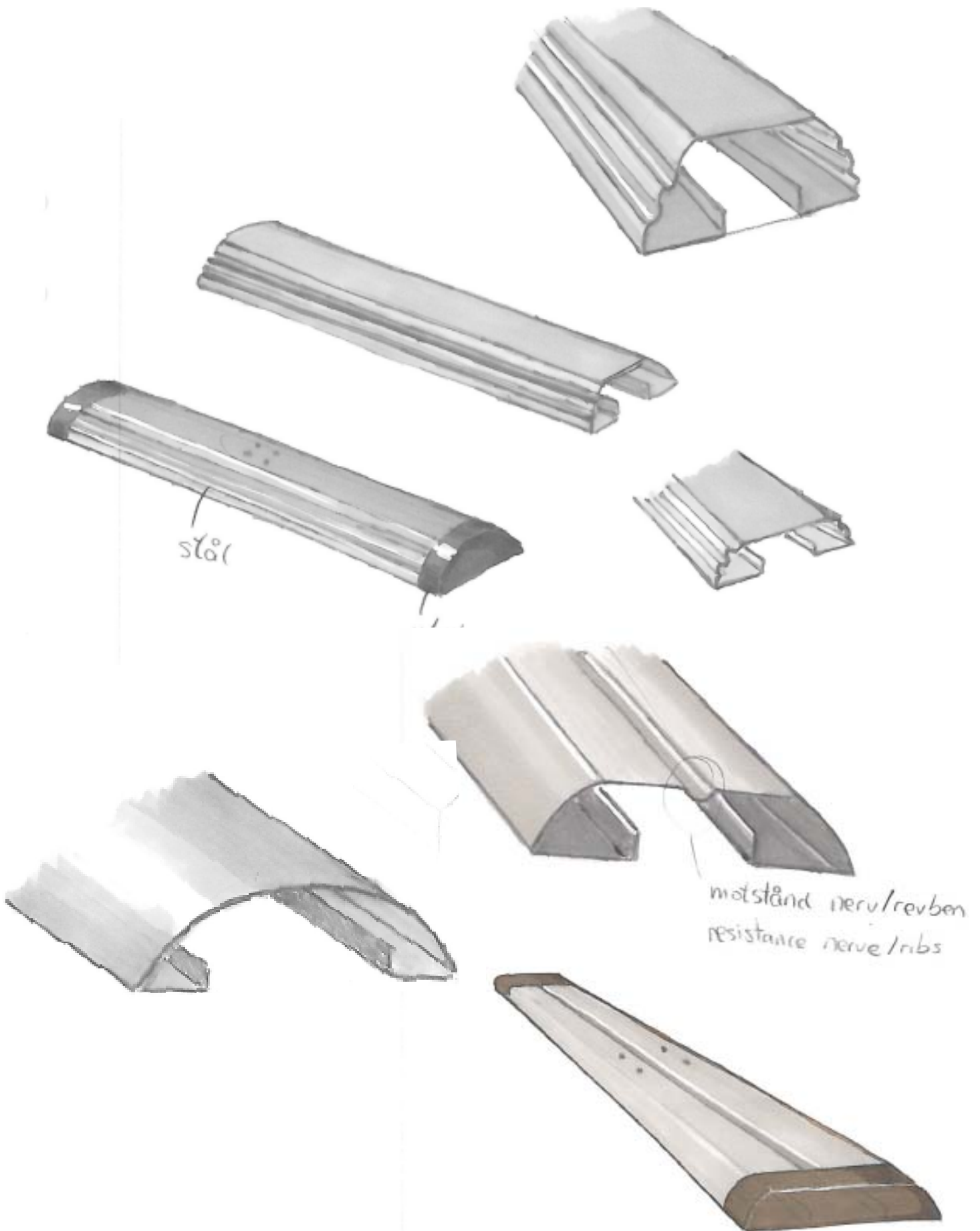



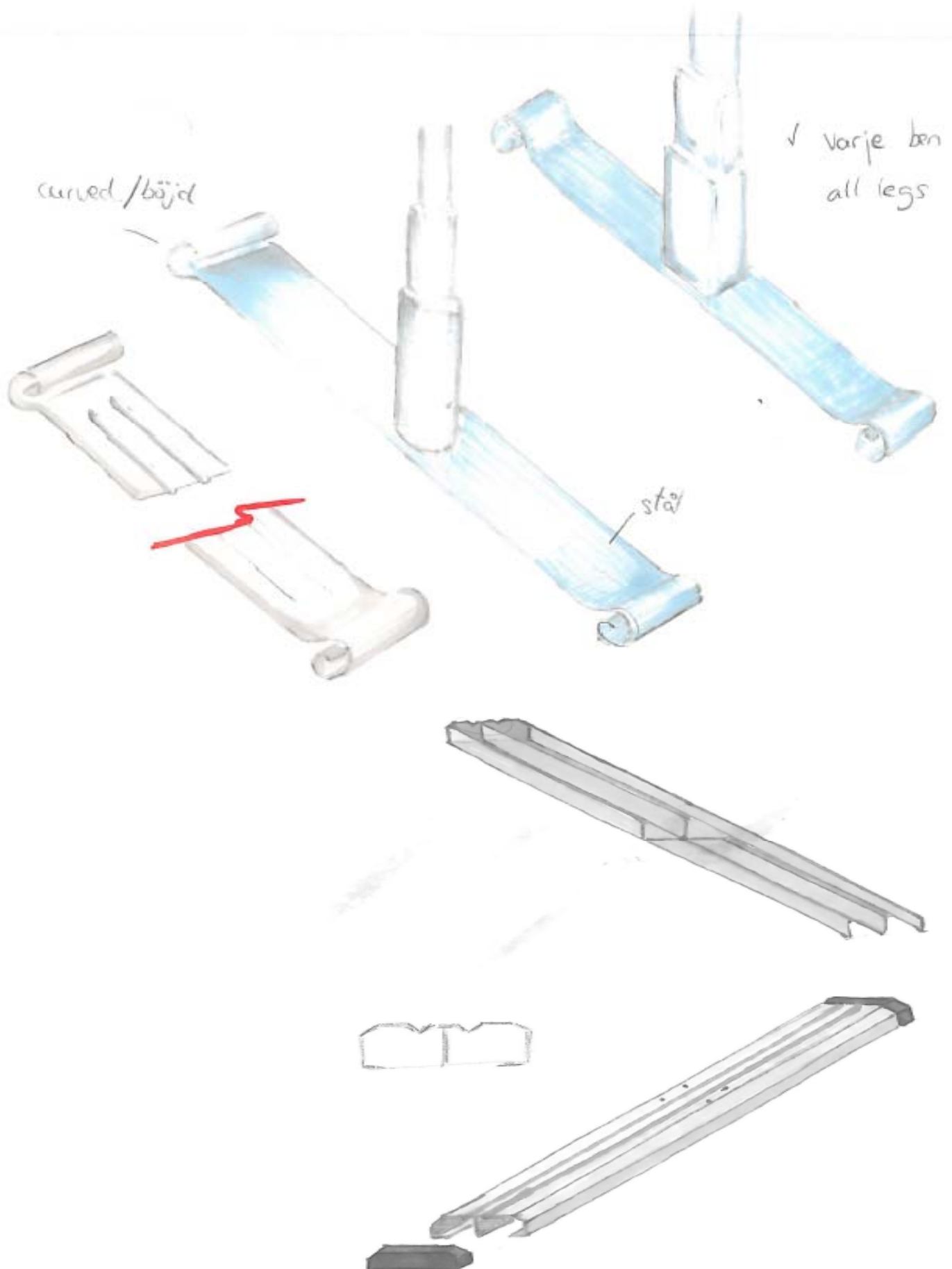

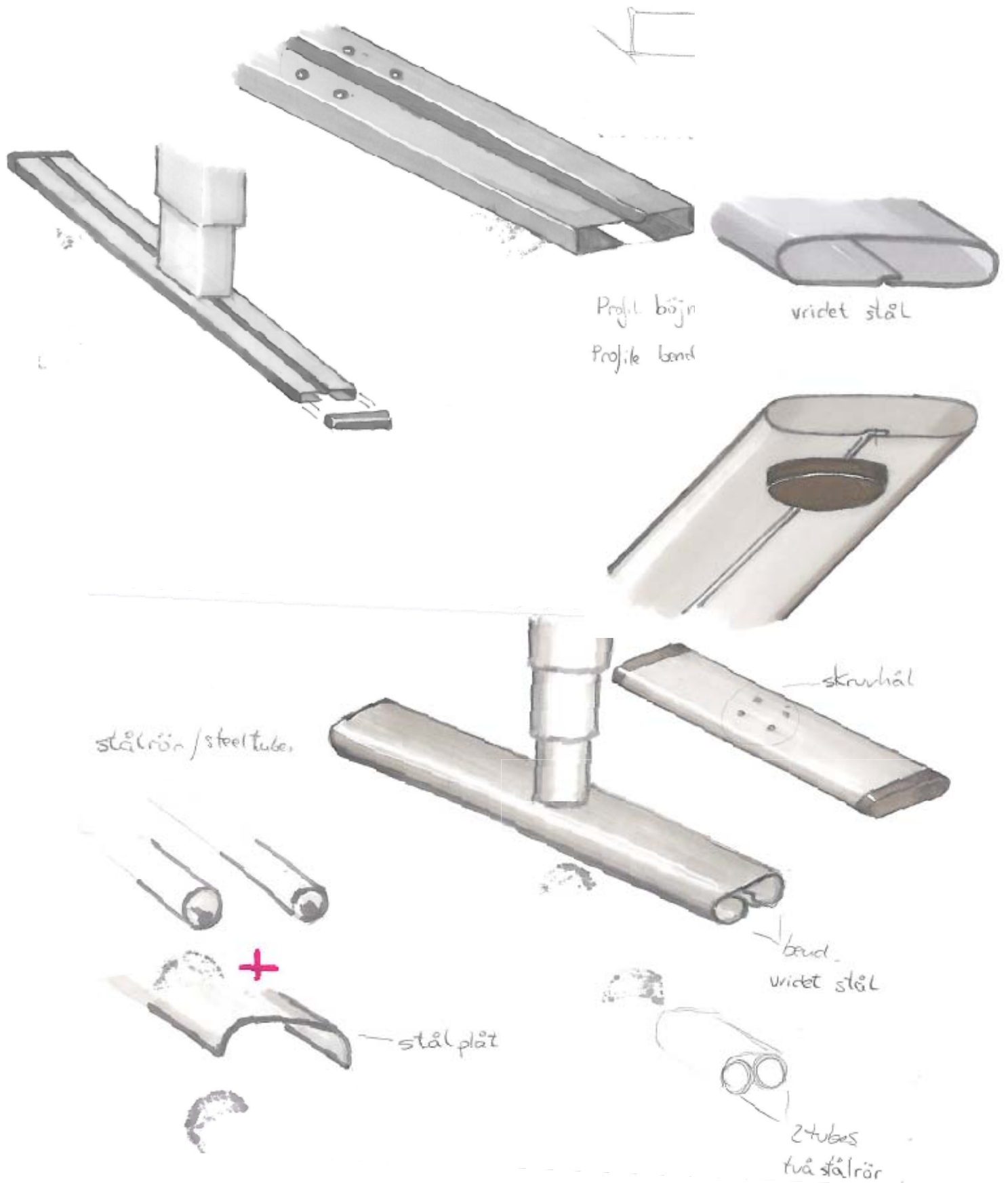

# Sketches. Group IV: Extendable foot

Very few pieces, many combinations

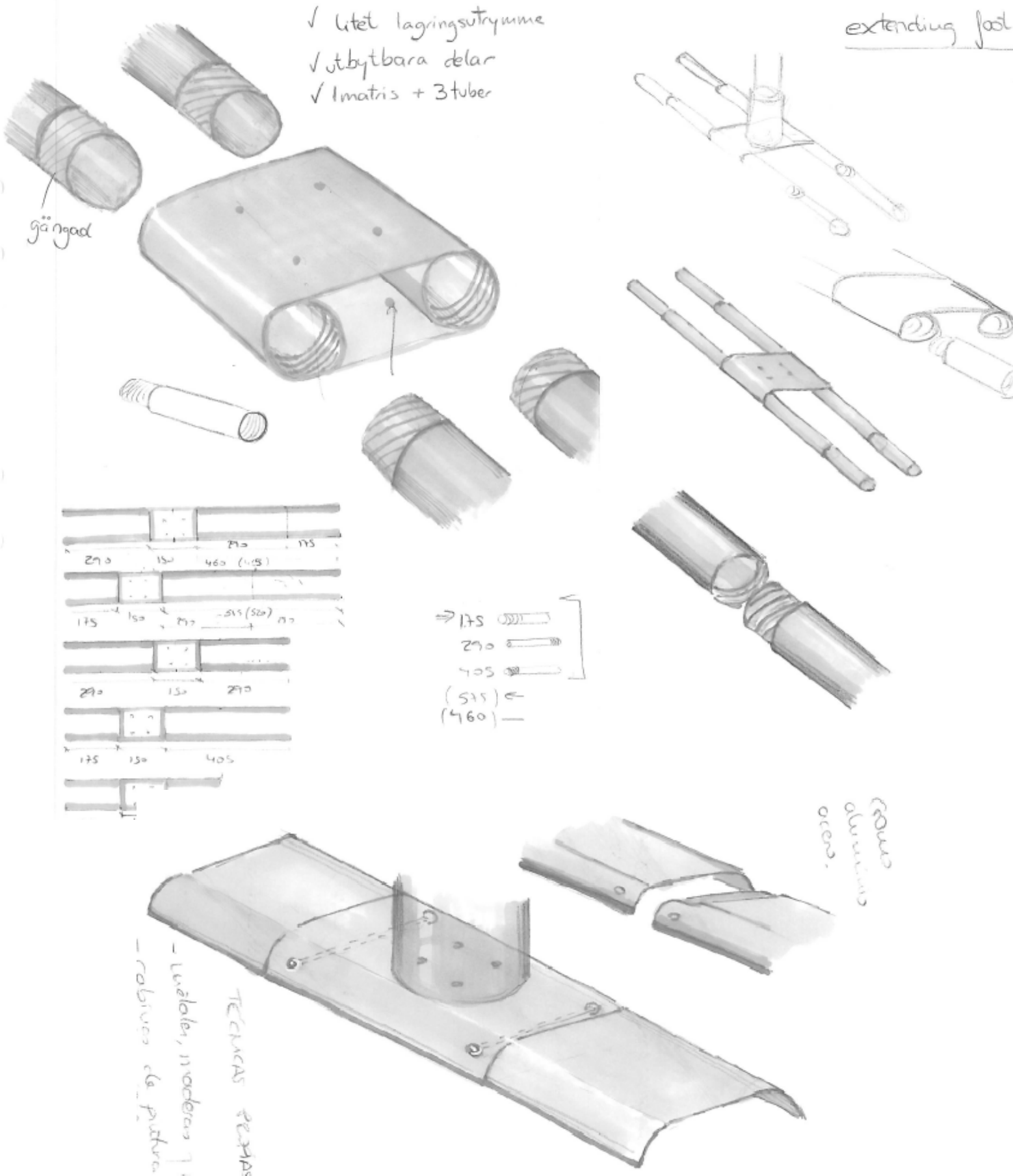

# Sketches. Group V: Feet with wheels

Wheels make it possible to move the table in all directions.

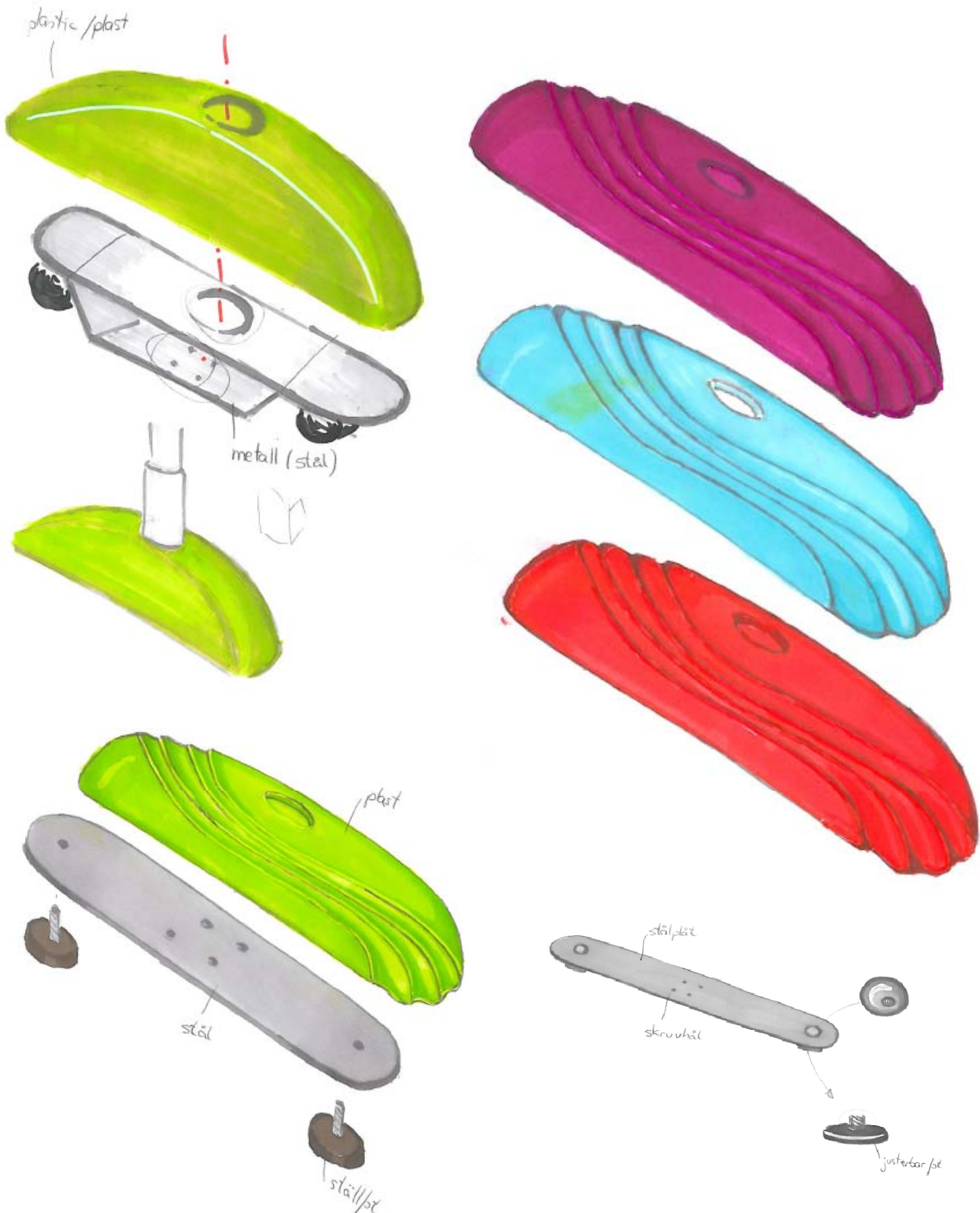

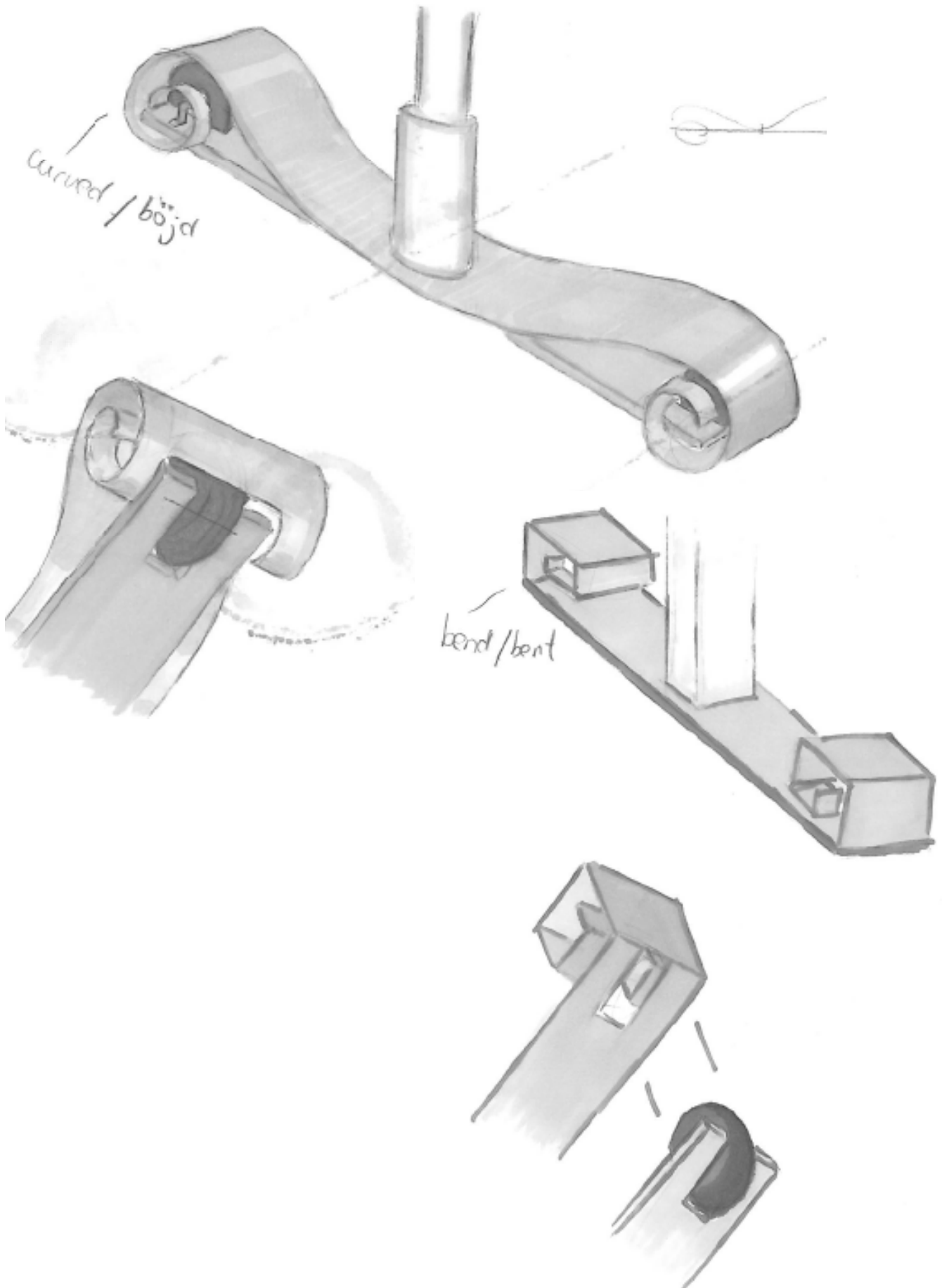



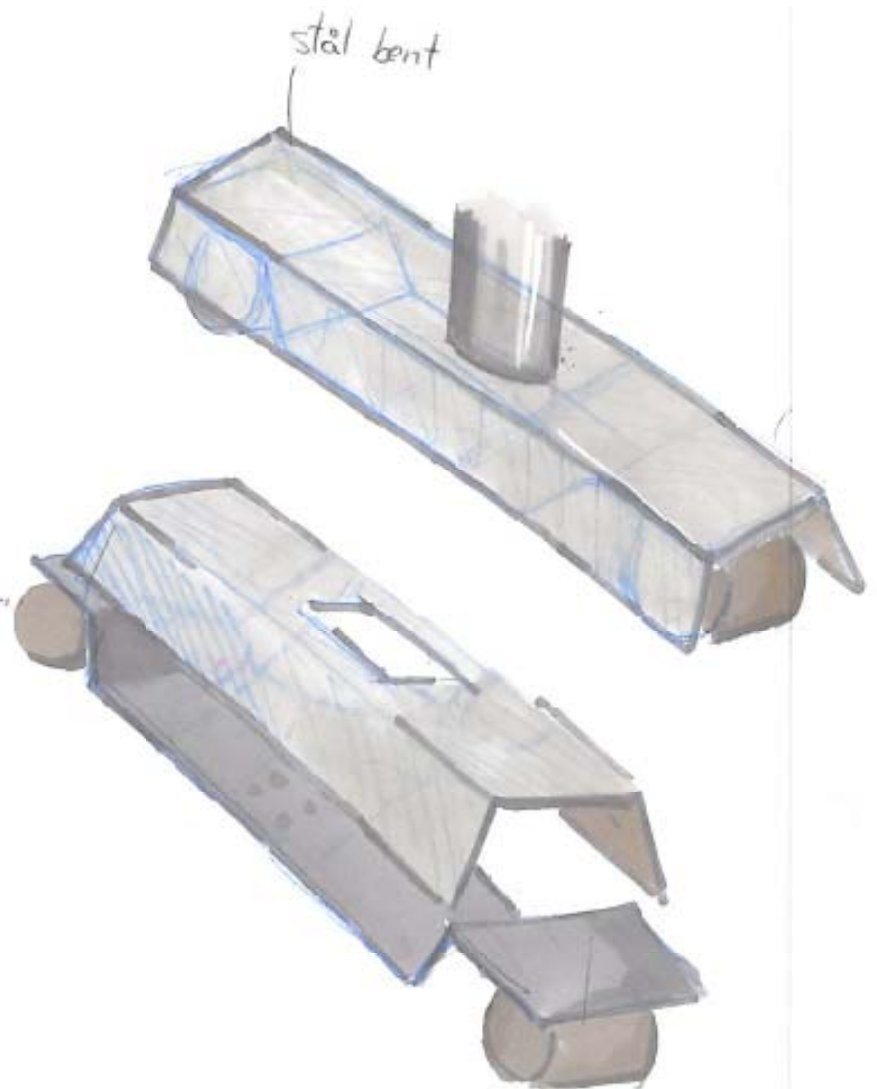
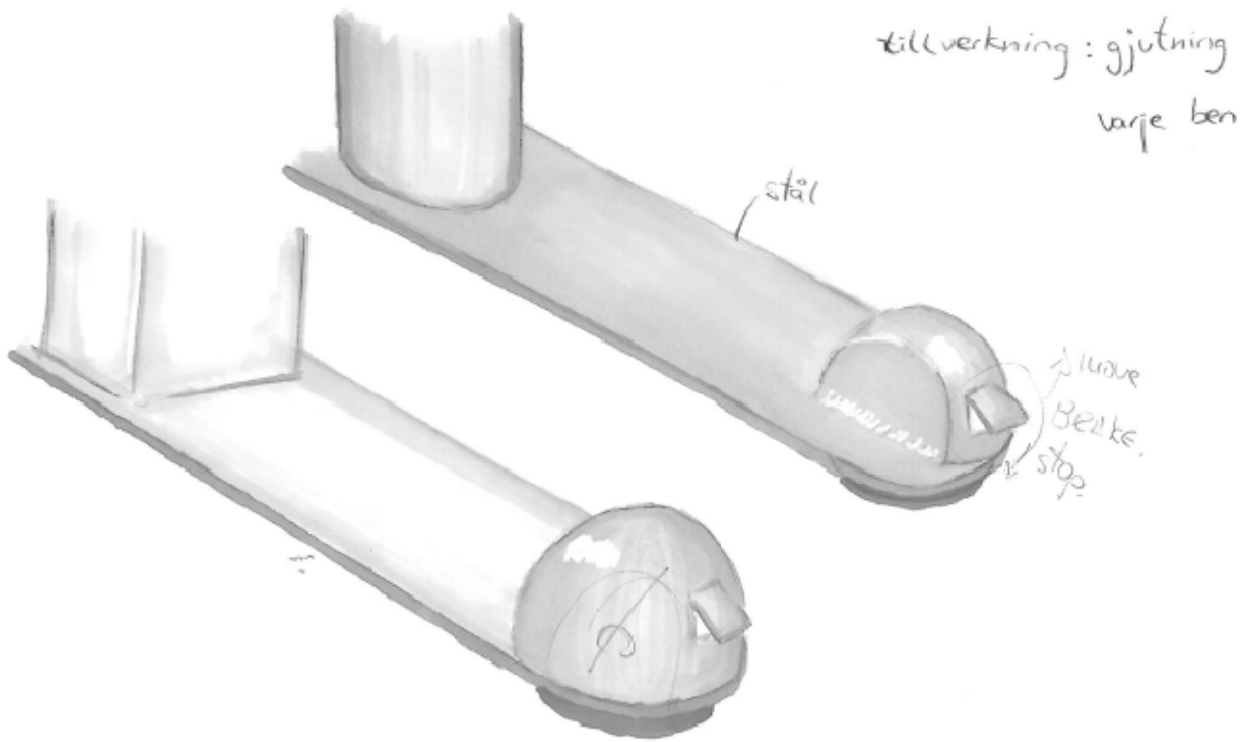

# Sketches. Group V: Feet with wheels

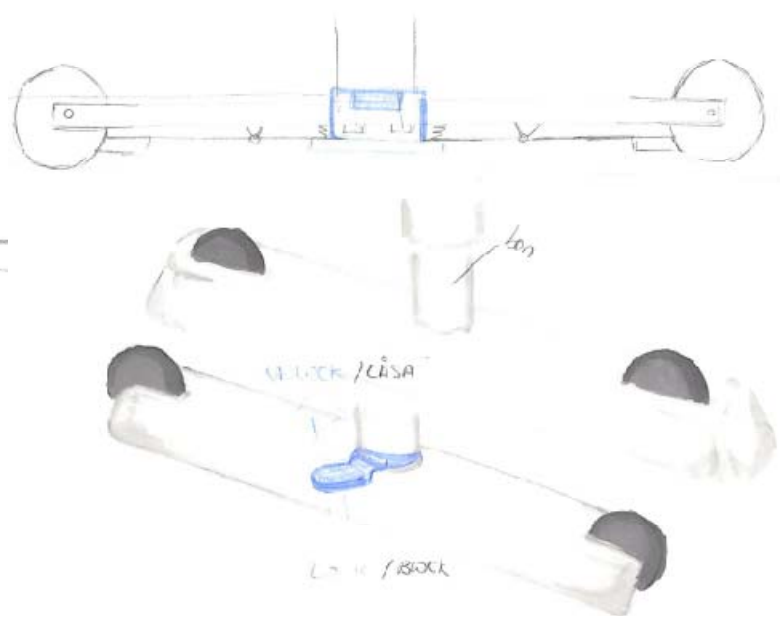
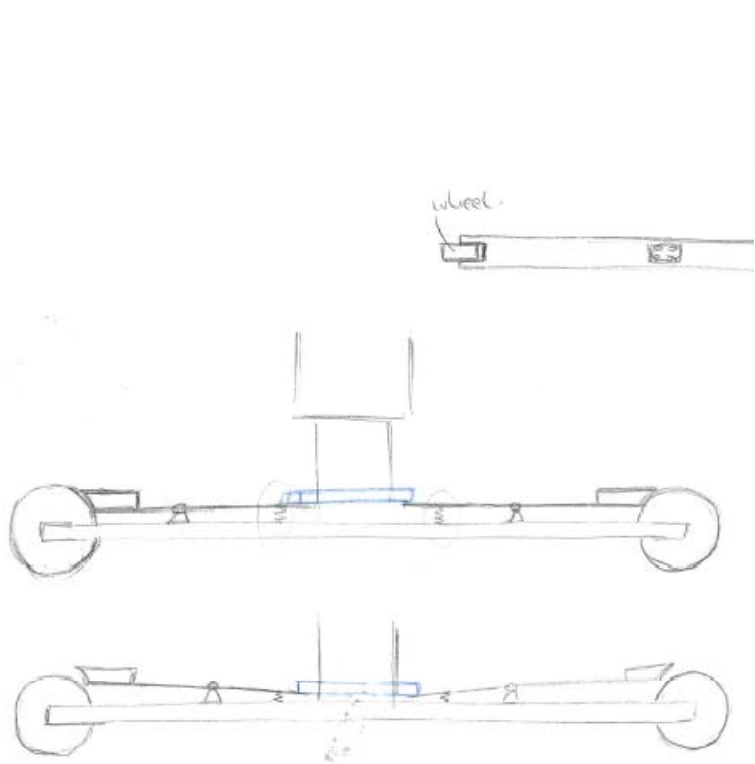

tillverkning : GJUTNING  
CASTING

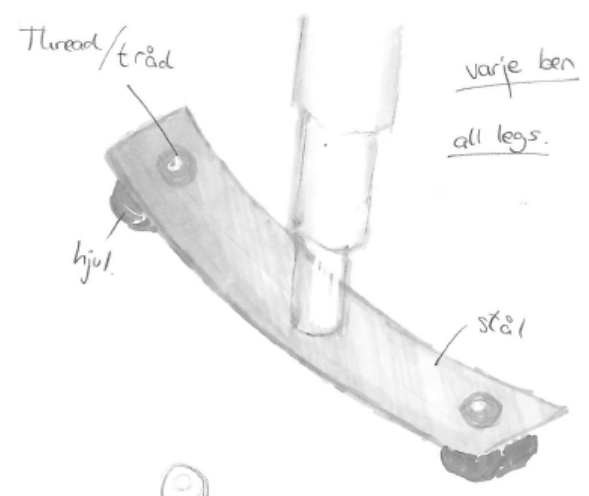
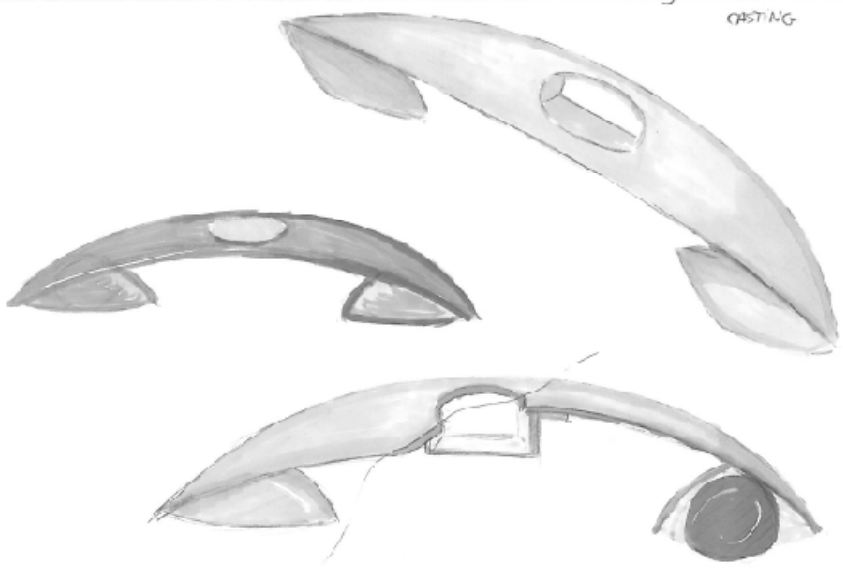



The table has electricity, which gives it more functions. Thanks to the sockets, one can for example charge a mobile phone or laptop there.

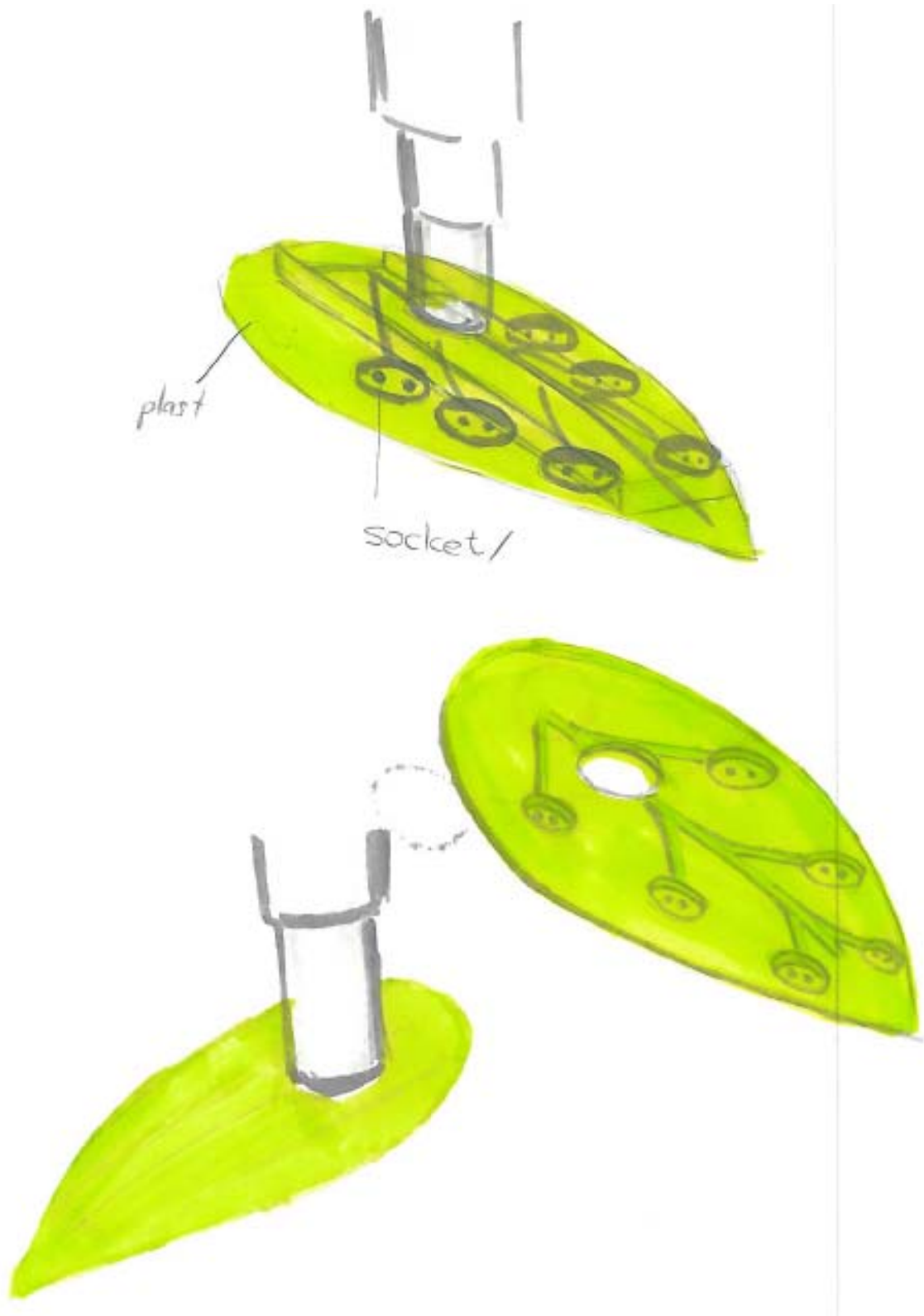

On 8<sup>th</sup> of October, Mia, Robert, Thomas and Dieter saw the drawings and decided how to continue the project:

*1<sup>st</sup> group: Rol's feet.* The foot is going to be produced according to the first design.

*2<sup>nd</sup> group: Pipes.* Two different pipes will be developed further: Straight pipes and curved pipes.

*3<sup>rd</sup> group: Steel bending.* It was decided that the design shape would work better in aluminium.

*4<sup>th</sup> group: Extendable foot.* It is not a good idea if one wants a good stability analysis.

*5<sup>th</sup> group: Feet with wheels.* They have the same problem as the extendable foot - it is not possible to obtain good stability analysis.

*6<sup>th</sup> group: Functional feet.* The company is of the view that it is a good idea to give the table more functions but this is not what they are looking for. However, the company is positive future usefulness of this project.

*Restrictions concerning the modeling in Autodesk Inventor 10:*

- Rol Ergo uses 4mm thick steel sheets.
  - Stand height with foot and tabletop: **670mm/650mm** (30204344, 30204303, 30204315)  
Stroke 500, tabletop 23mm (against or inside)
  - Stand height with foot and tabletop = **620 mm** (30204816, 30204364)  
Stroke 650, tube against upper part of foot
  - Stand height with foot and tabletop= 640mm (30204327)  
Stroke 650, tube "inside" the foot.
  - Suitable for 80x60, 60x40 rectangular tubes
  - Suitable for Ø80, Ø60 round tubes
- If it's possible, suitable for 80x60, 60x40, Ø60, Ø80
- All colors or chrome
  - Length  
L= 500, L= 730, L=900  
Hole position: 250, 365
  - Any restriction for the pipes.
  - Any restriction for the aluminium foot.

## *Modeling in Autodesk Inventor 10*

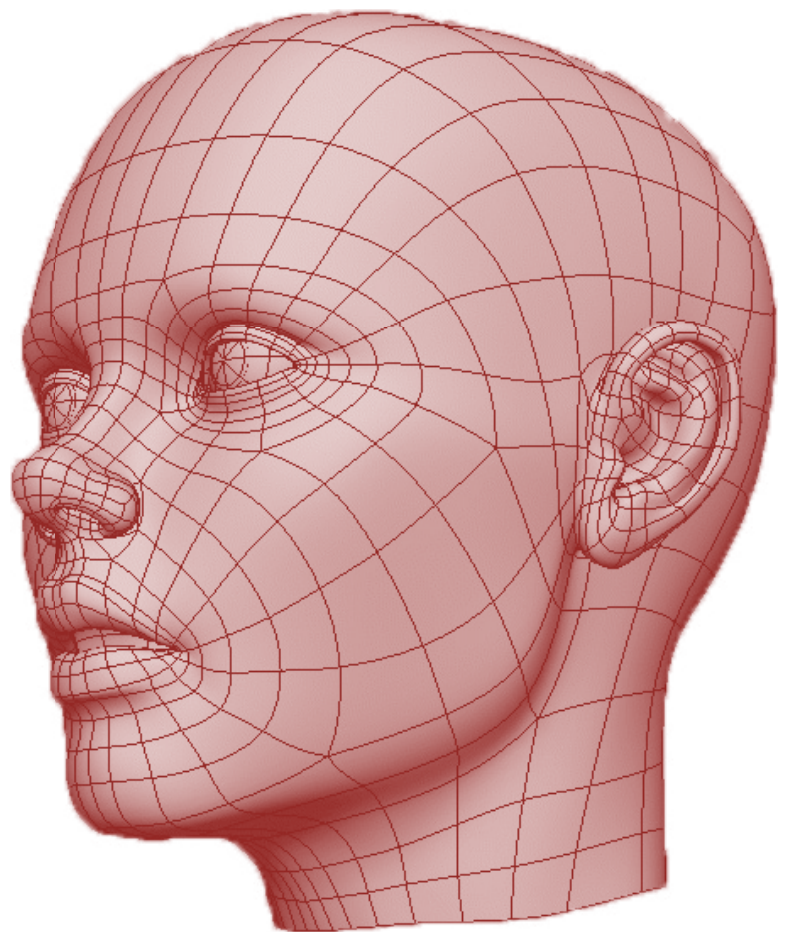

This foot has been designed for  $\varnothing 60$  round tubes:

Stand ED 500 Round (30204344)

Stand ED 650 Round (30204327)

The difference between 30204344, 30204327 and 30204303, 30204816 is the position of the washer:

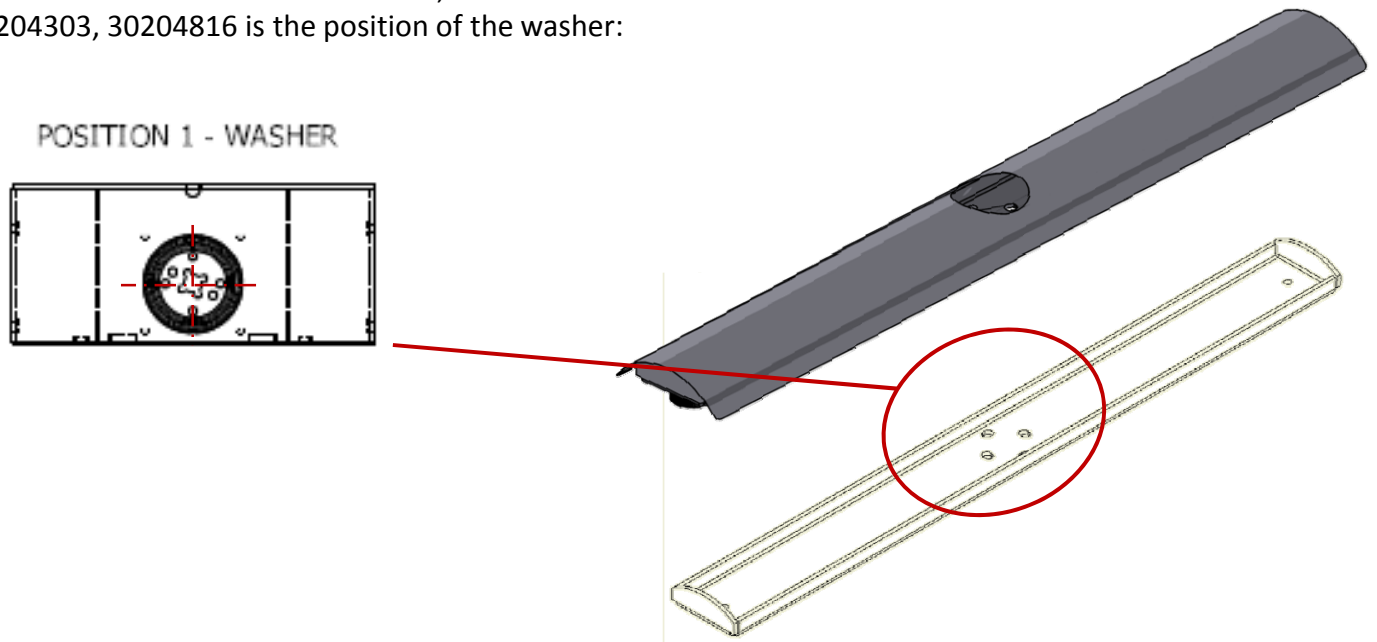

This foot has been designed for  $\varnothing 60$  and  $\varnothing 80$  round tubes:

Stand ED 500 Round (30204303)

Stand ED 650 Round (30204816)

Stand DM Sync 600 Round (68000419)

Stand USD Sync 650 Round (68000238)

Position 2 of the washer:

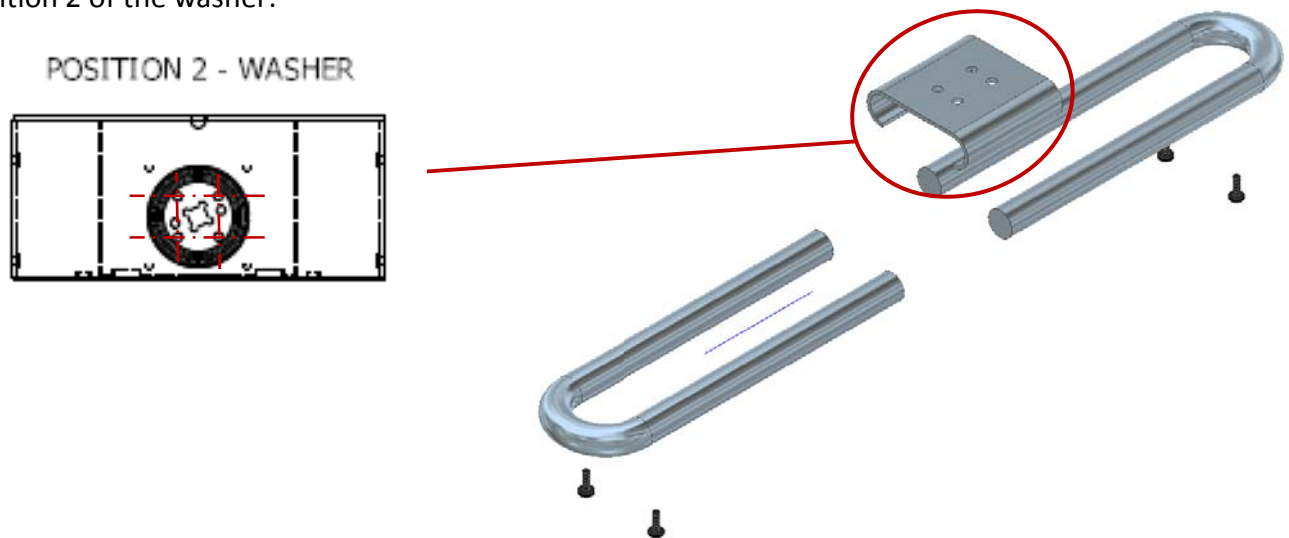

Like in Model 1, this foot has been designed for  $\varnothing 60$  and  $\varnothing 80$  round tubes:

Stand ED 500 Round (30204303)

Stand ED 650 Round (30204816)

Stand DM Sync 600 Round (68000419)

Stand USD Sync 650 Round (68000238)

Position 2 of the washer.

The first modeling was too big, so I decided to model the foot with a more slender shape.

This foot is composed of two curved pipes which are joined in the middle of the foot. The curvature radius is too small and might cause the pipe to break there. The solution is shown in model 2.1





This foot has the same shape as Model 2, but the construction is different.

Instead of curving the pipes too much and joining them in the middle, with this design the pipes are joined in the endings and the endings are hidden with a cover.

The cover is made of plastic so the customer can choose the colour of the endings and customize the table.

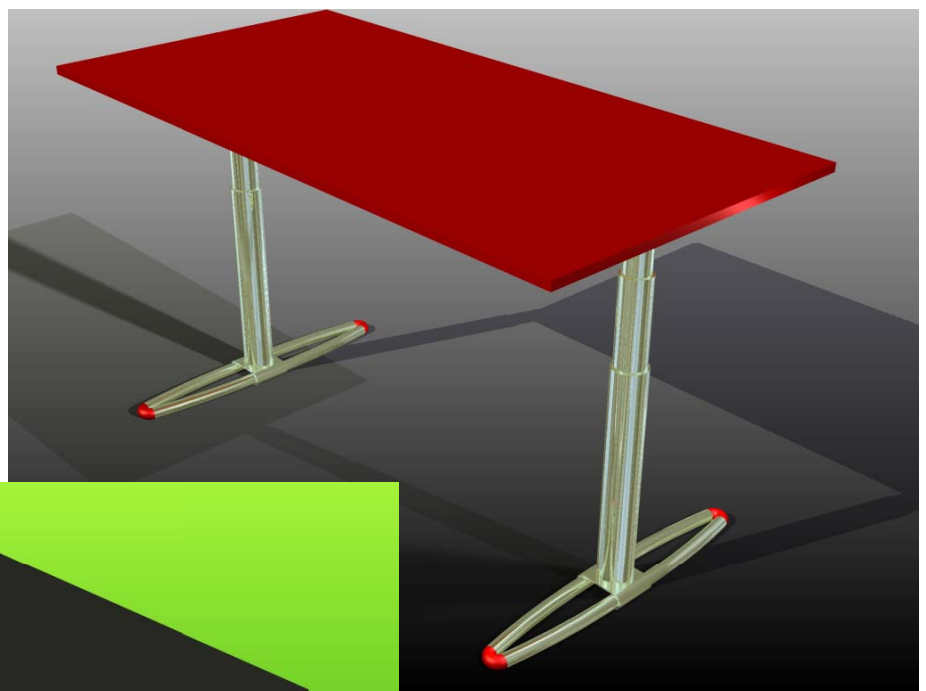
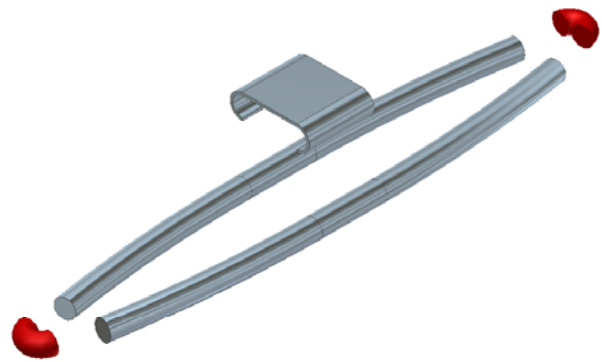



Like in Model 1, this foot has been designed for  
Ø60 and Ø80 round tubes:  
Stand ED 500 Round (30204303)  
Stand ED 650 Round (30204816)  
Stand DM Sync 600 Round (68000419)  
Stand USD Sync 650 Round (68000238)

POSITION 2 - WASHER

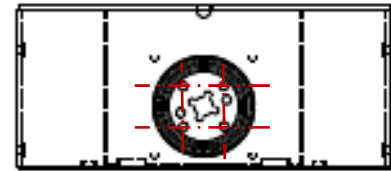

This foot is the easiest to manufacture.  
The endings are connected to the adjustable  
feet through a 5mm thick metal sheet.  
The adjustable feet are hidden in the ending  
covers.



This foot has been designed for  $\varnothing 60$  and  $\varnothing 80$  round tubes:

Stand ED 500 Round (30204303)

Stand ED 650 Round (30204816)

Stand DM Sync 600 Round (68000419)

Stand USD Sync 650 Round (68000238)

POSITION 2 - WASHER

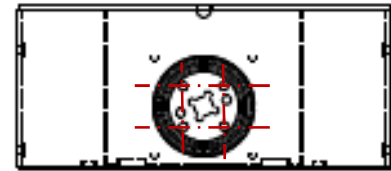

The customer can choose the colour of the plastic sheets on both sides of the feet. Moreover, the foot covers may display customer-specified designs.

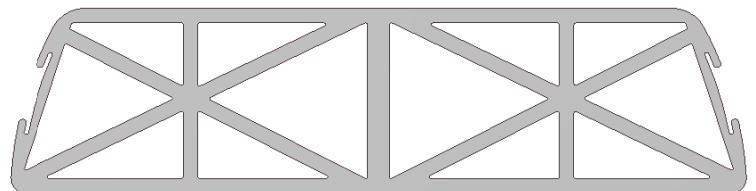

This foot has been designed for  $\varnothing 60$  and  $\varnothing 80$  round tubes:

Stand ED 500 Round (30204303)

Stand ED 650 Round (30204816)

Stand DM Sync 600 Round (68000419)

Stand USD Sync 650 Round (68000238)

The customer can choose the colour of the plastic sheets on both sides of the feet. Moreover, the foot covers may display customer-specified designs.

Profile using the least amount of materials was identified and was later used in the tension analysis for various designs.

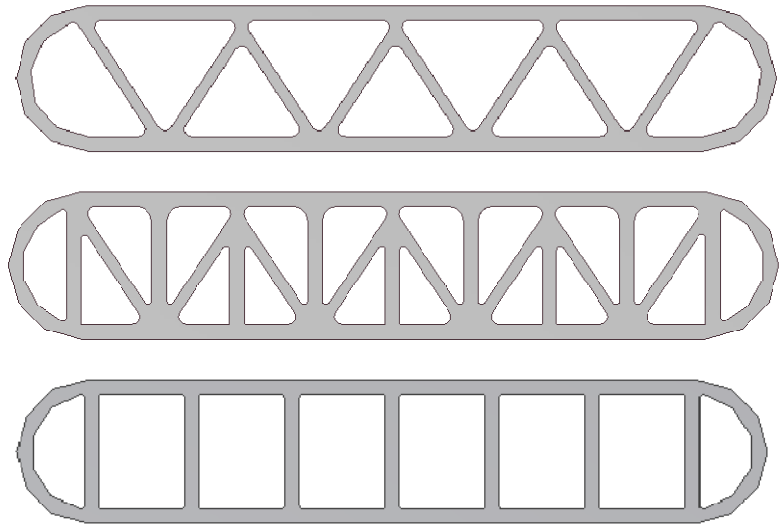

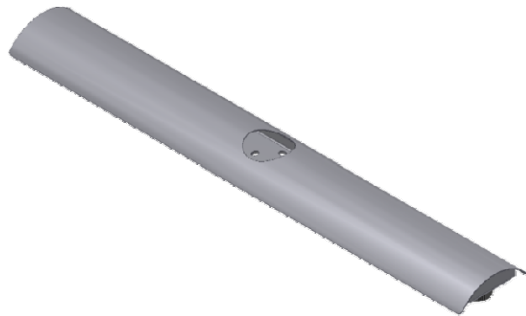
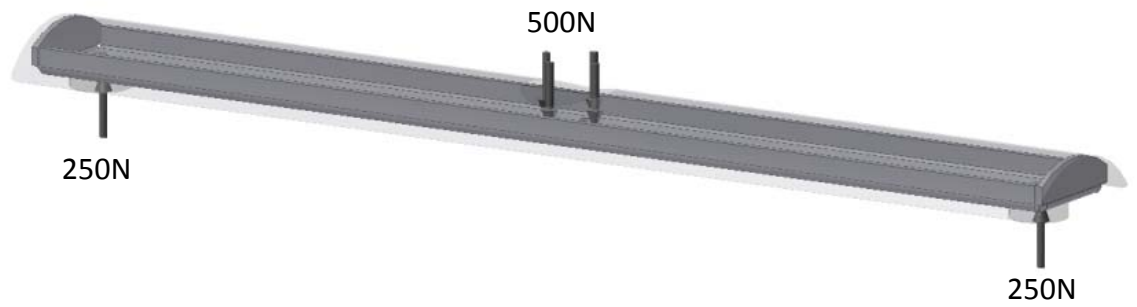

**STEEL**

$\delta_{max} = 0,328\text{mm}$   
 $\tau_{max} = 186,26\text{ MPa}$



**ALUMINUM**

$\delta_{max} = 0,430\text{mm}$   
 $\tau_{max} = 40,194\text{ MPa}$



**ALUMINUM**

$\delta_{max} = 0,368\text{mm}$   
 $\tau_{max} = 88,939\text{ MPa}$



**ALUMINUM**

$\delta_{max} = 0,427\text{mm}$   
 $\tau_{max} = 85,751\text{ MPa}$

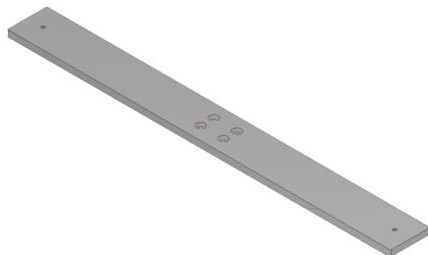

**ROL 30204588**

**STEEL**

$\delta_{max} = 0,224\text{mm}$   
 $\tau_{max} = 174,91\text{ MPa}$



**ROL 30202713**

**STEEL**

$\delta_{max} = 0,287\text{mm}$   
 $\tau_{max} = 96,259\text{ MPa}$

**ALUMINUM**

$\delta_{max} = 0,489\text{mm}$   
 $\tau_{max} = 92,93\text{ MPa}$

On 26<sup>th</sup> of October, Dag, Mia, Robert, and Thomas saw the modeling and decided how to continue the project:

1 <sup>st</sup> group	<i>Inspired by Rol's feet</i>	The prototype is going to be manufactured without changes.
2 <sup>nd</sup> group	<i>Pipes. Model 1</i>	It's hard to make the prototype and the company does not have the machine to bend the pipes.
	<i>Pipes. Model 2</i>	It's not a good design because the curvature radius is too small and there is a high probability of the pipe breaking.
	<i>Pipes. Model 2.1</i>	Design should be developed further
	<i>Pipes. Model 3</i>	The prototype is going to be manufactured without changes.
3 <sup>rd</sup> group	<i>Aluminium. Model 1</i>	The feasibility of the profile is unknown.
	<i>Aluminium. Model 2</i>	The profile and the stickers are a good idea, but they need to be discussed with Sapa profiler AB.

Additionally, a sidebar has to be designed for each foot.

After visiting Sapa Profiler AB and show them our profiles, they sent us their solution.

Thomas and me thought that their solution was not good enough because:

- Four adjustable feet must be screw instead of two like the rest of the feet.
- Side zones are not strong enough.

However, doing the prototype is too expensive so the development of this foot ends here.

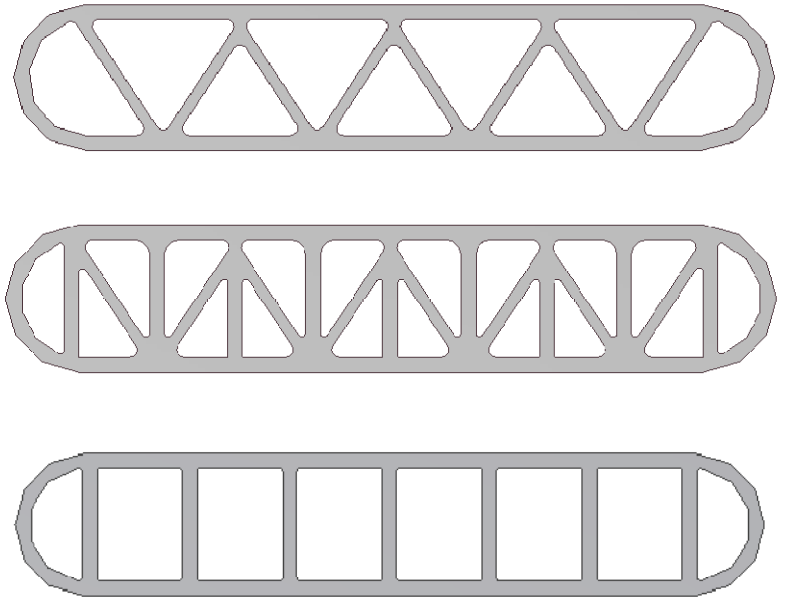

1rs profiles

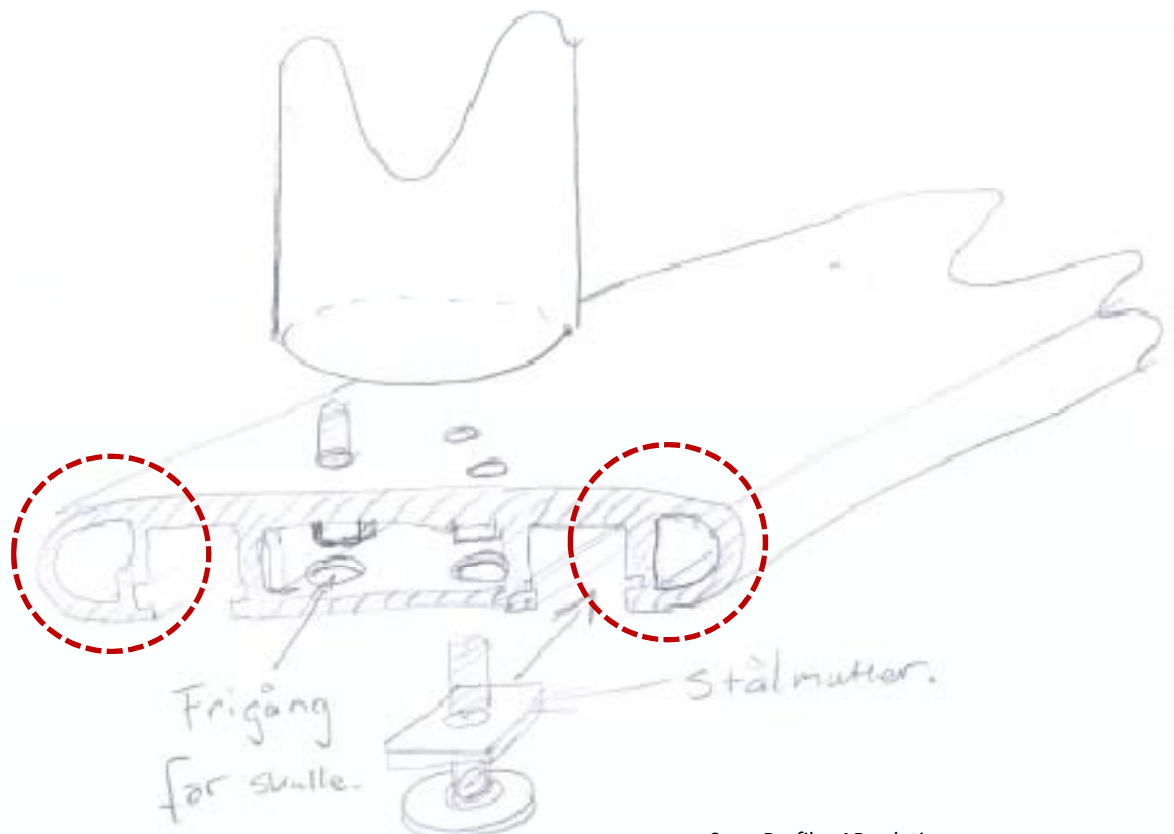

Sapa Profiler AB solution



*Development*

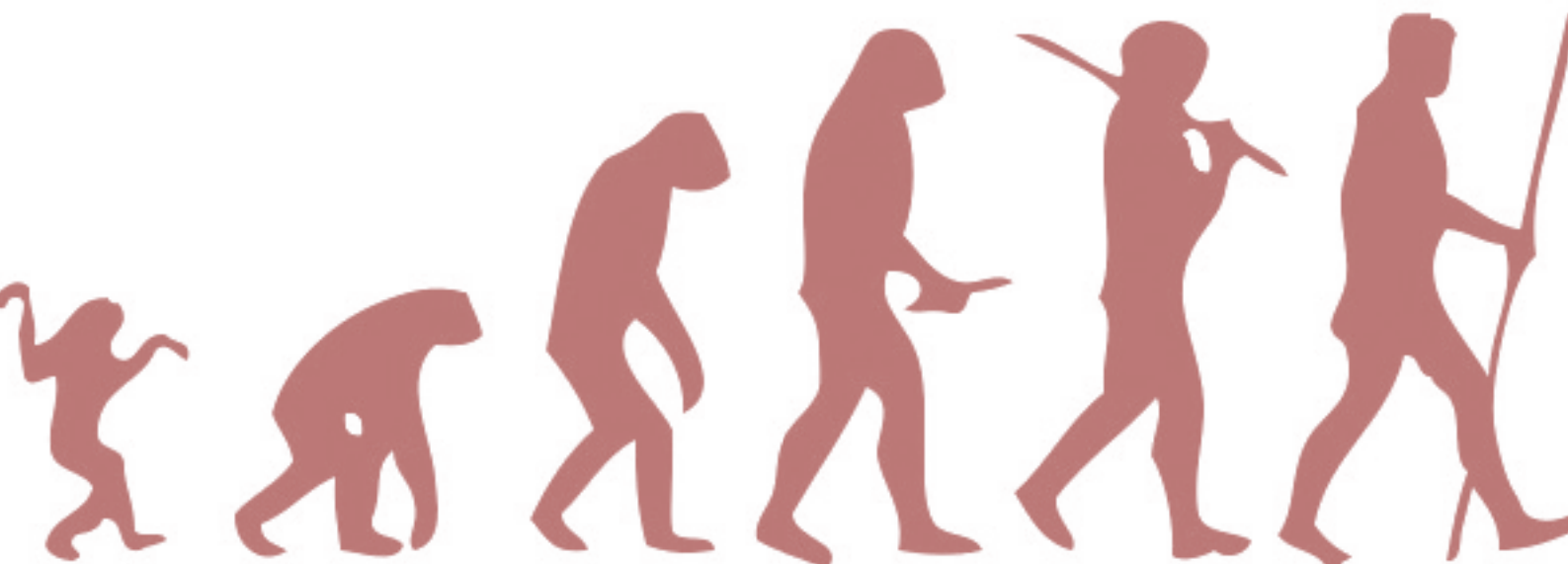

The sidebar shape is similar to the frame that Rol Ergo has.

The first design was a curve sidebar, but as it was difficult to manufacture, the final prototype is S-shaped

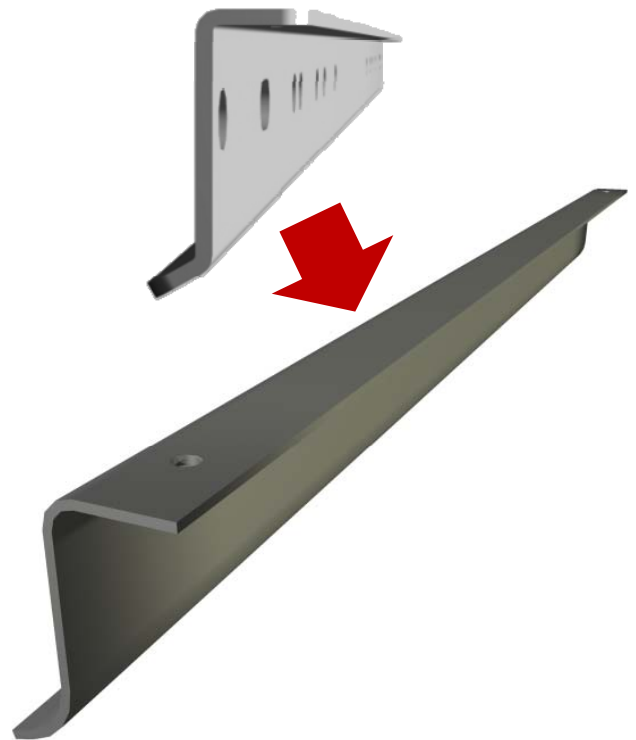

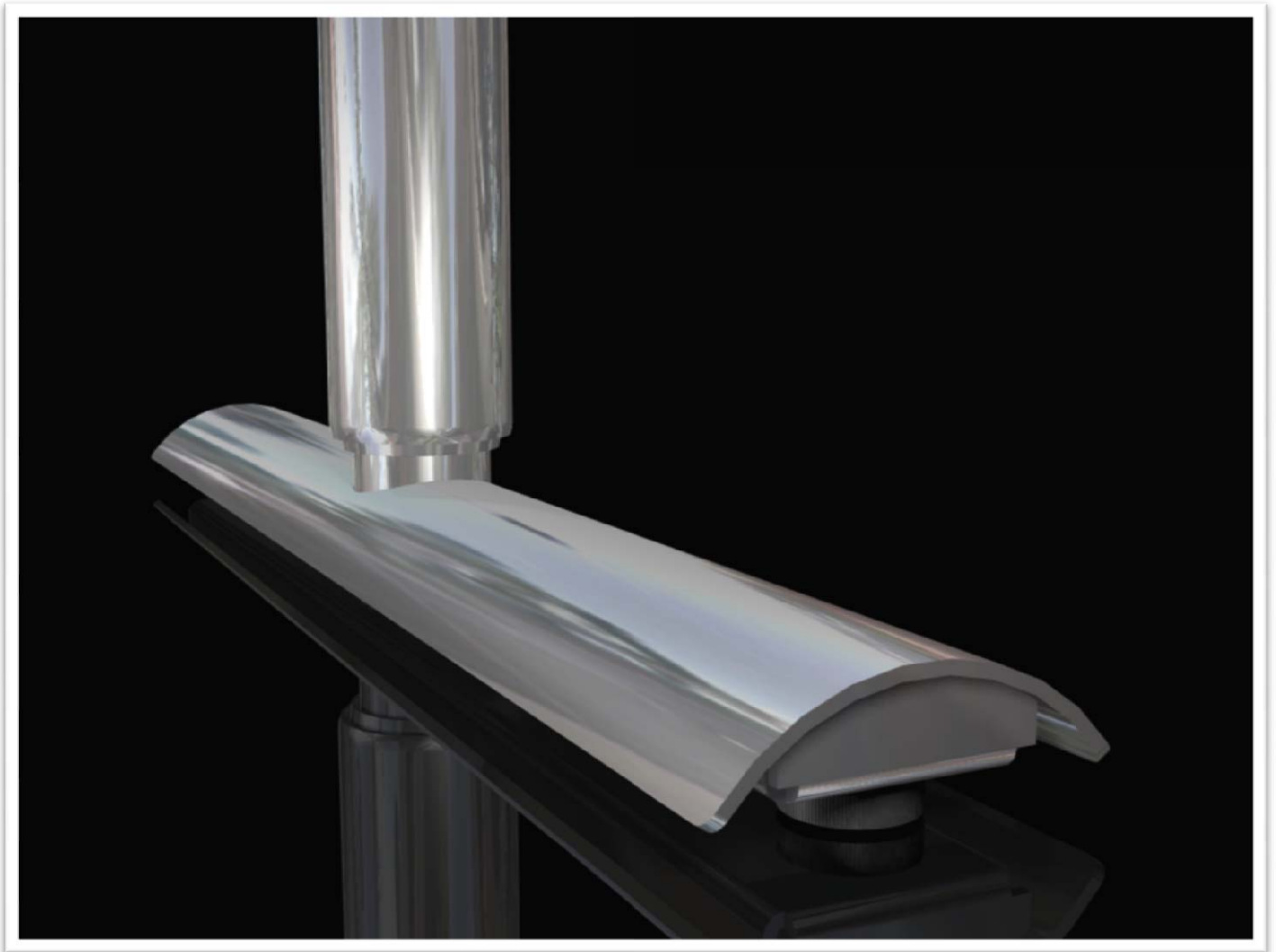



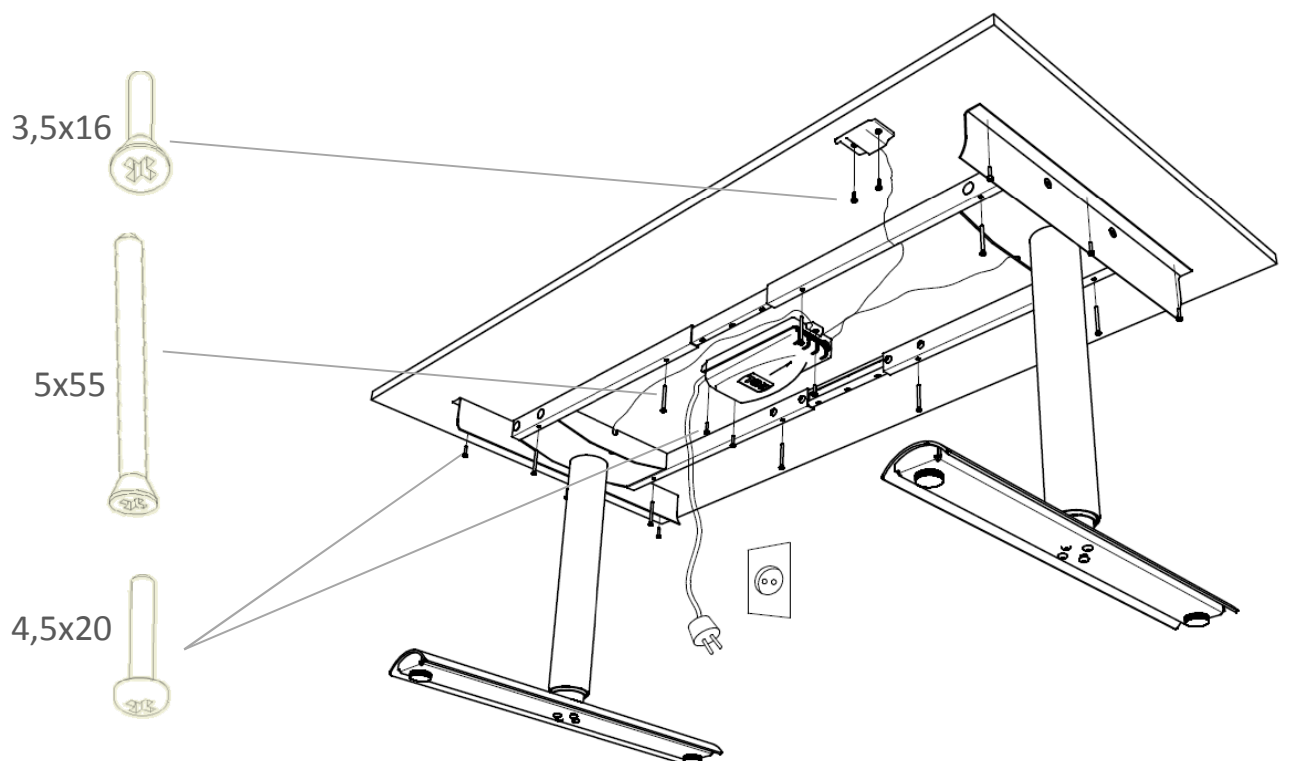
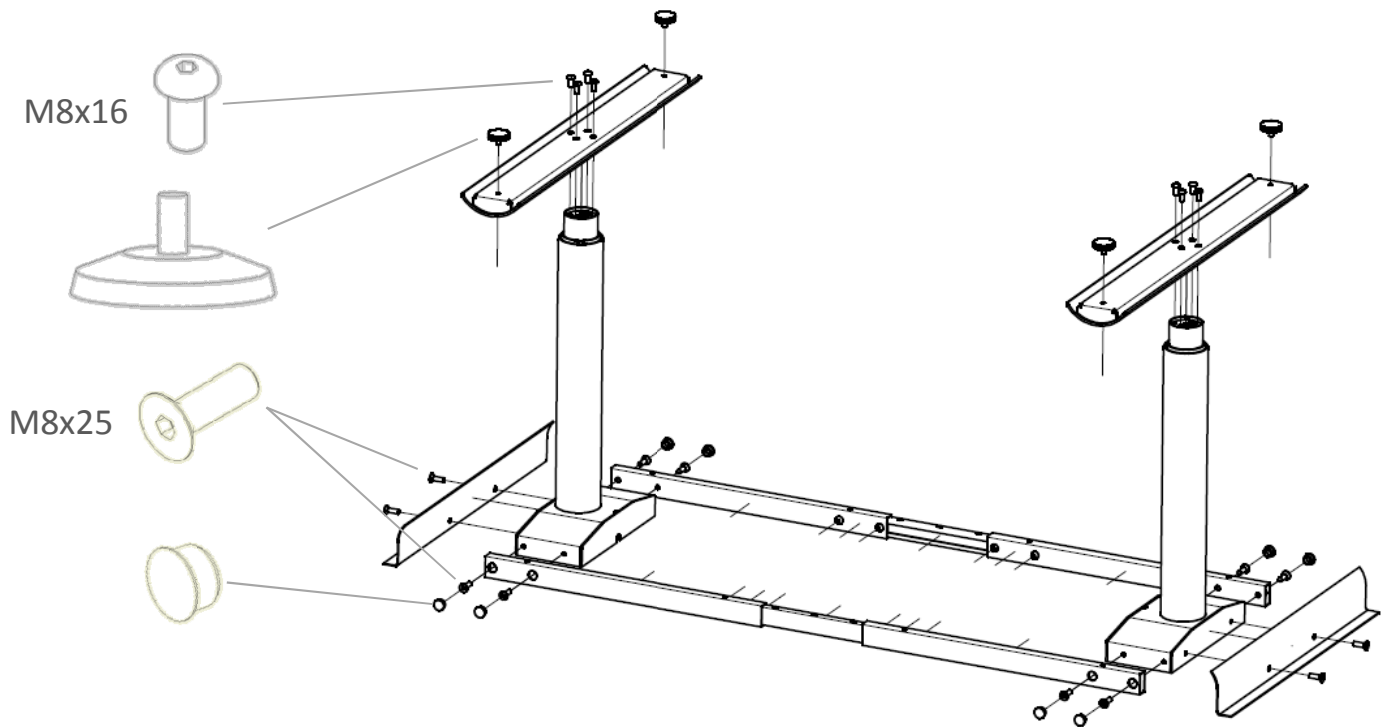

The sidebar has been made with the same pipe as the foot.

In the endings it has a plastic component to prevent injuries.

To screw the sidebar, the pipe is welded with a L-shaped metal sheet.

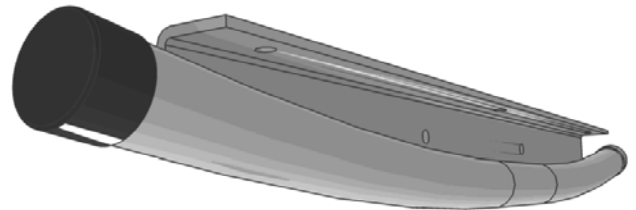



## Ending 1

- ✓ This ending follows pipe's shape.
- ✗ Adjustable feet can not be hidden.
- ✗ Pipe ending has to be completely round.
- ✗ Welding points can not be hidden.

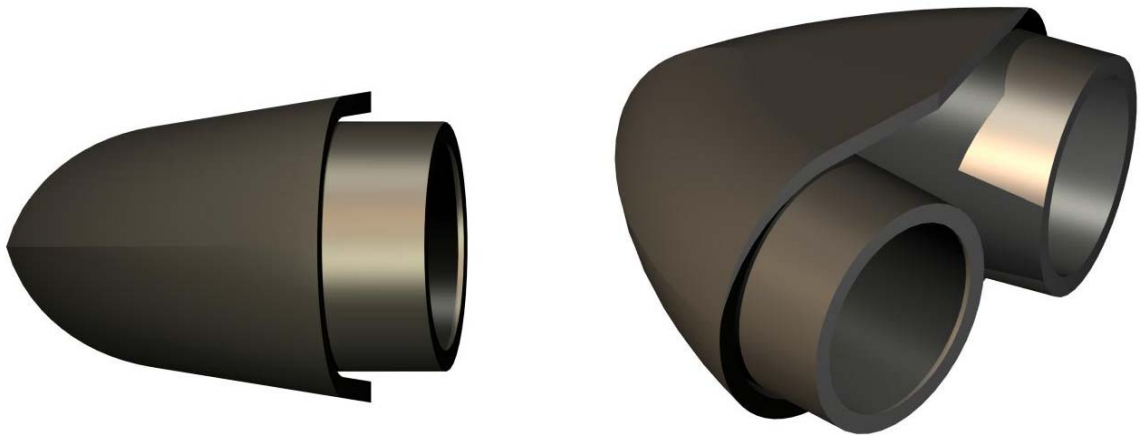

## Ending 2

- ✓ The ending protects user's feet.
- ✓ Adjustable feet can be hidden.
- ✓ Pipe ending has not to be completely round.
- ✓ Welding points can be hidden.

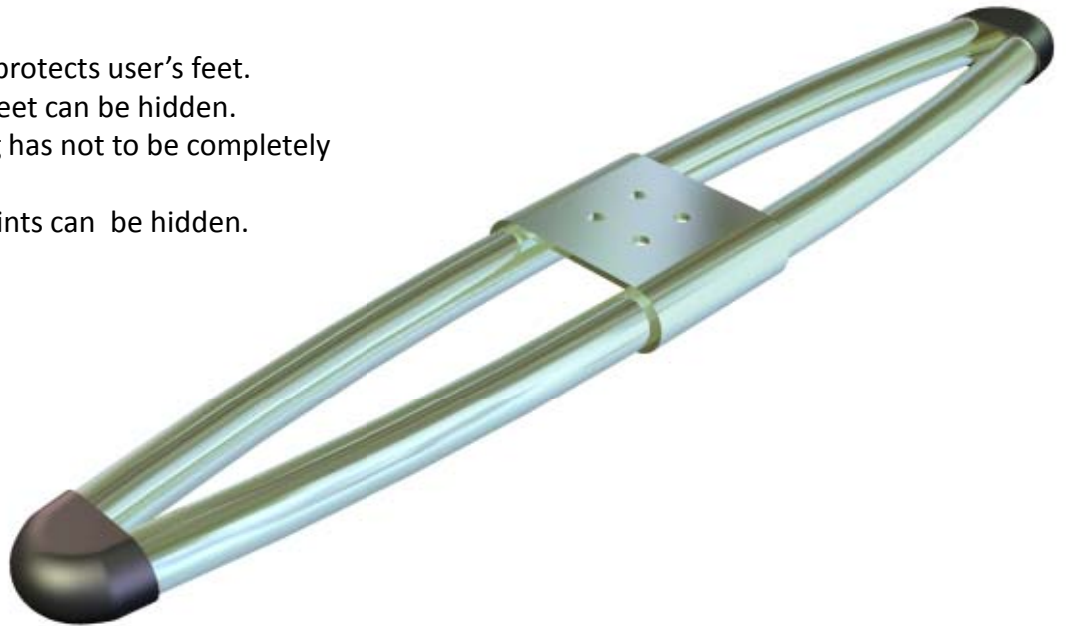

## Ending 3

- ✓The ending protects user's feet.
- ✓Adjustable feet can be hidden.
- ✓ Pipe ending has not to be completely round.
- ✓ Welding points can be hidden.
- ✓This ending follows pipe's shape

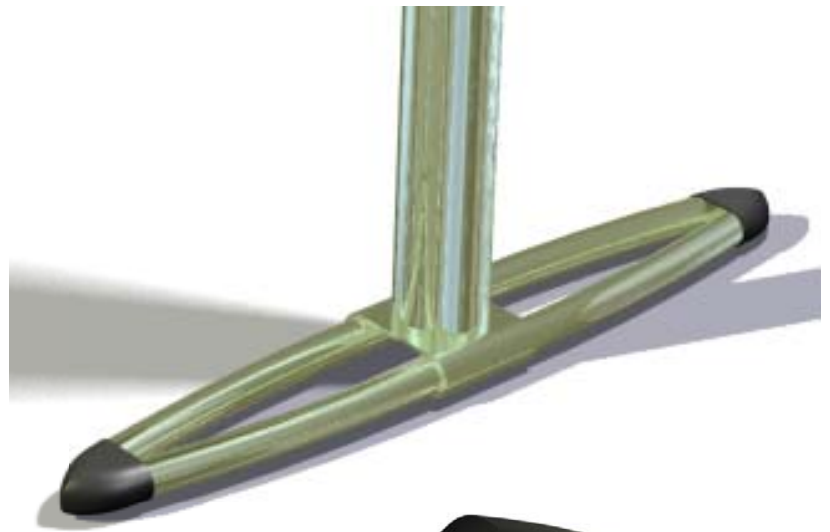





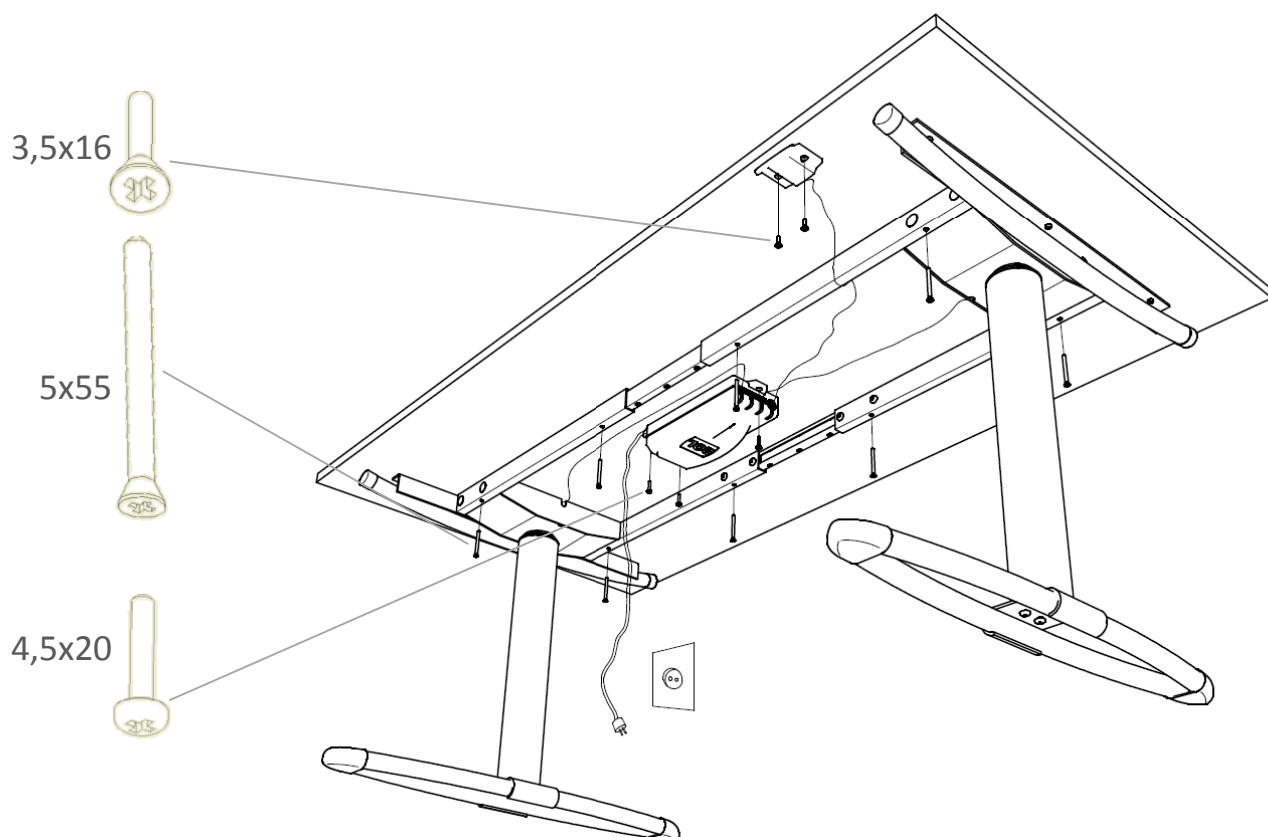
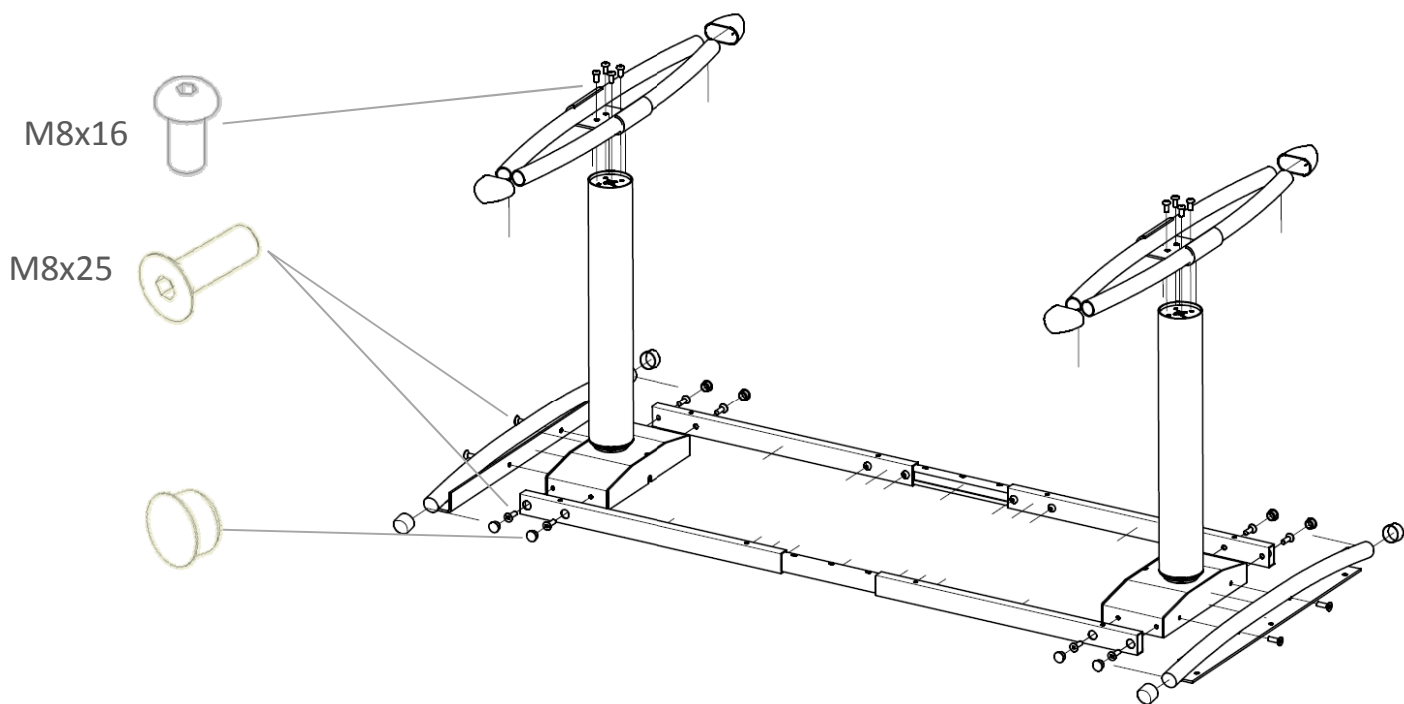



The sidebar has been made with the same pipe as the foot.

In the endings it has a plastic component to prevent injuries.

To screw the sidebar, the pipe has holes.

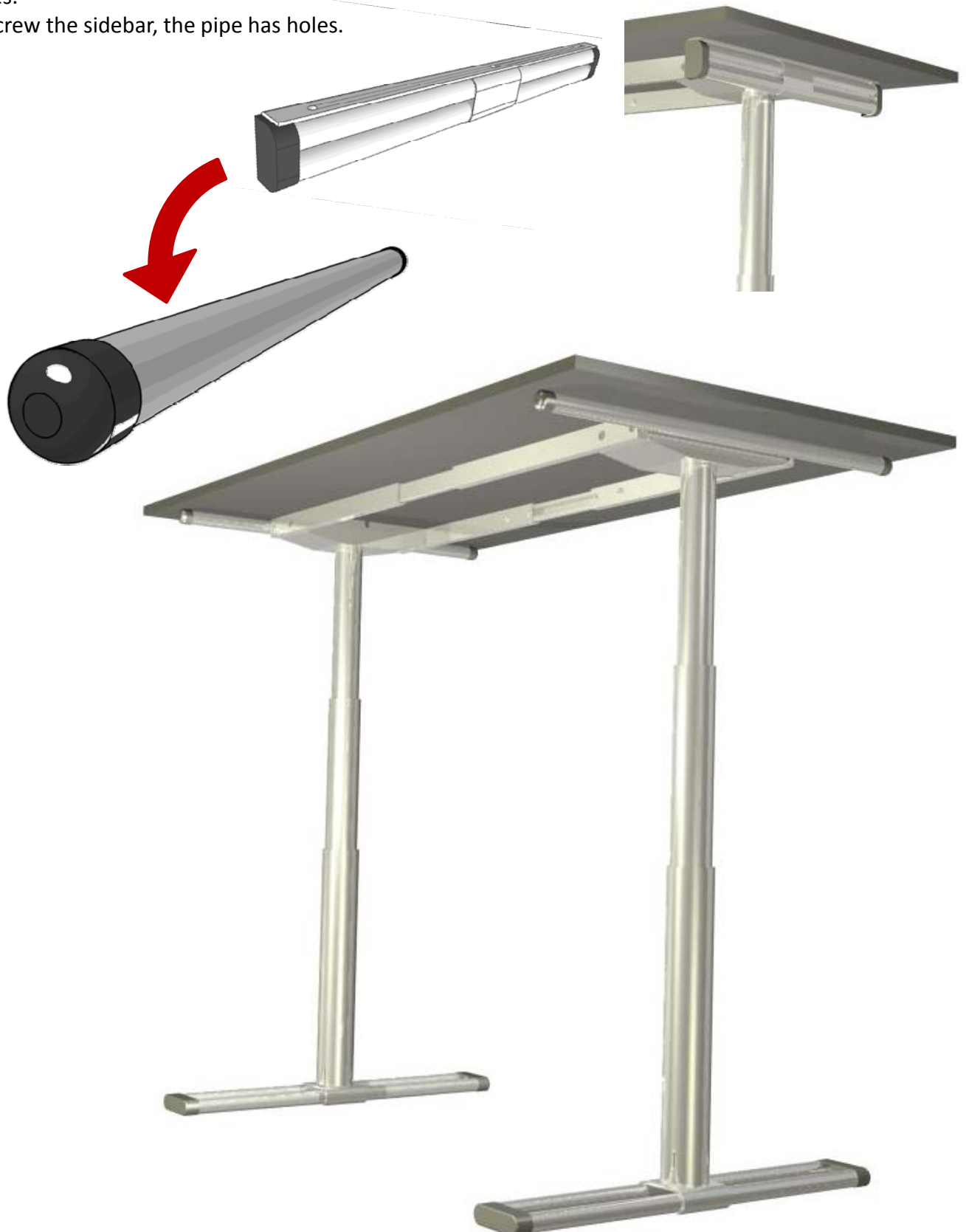

### Ending 1

The final design hides the adjustable foot and the welding 5mm metal sheet that joins both pipes.

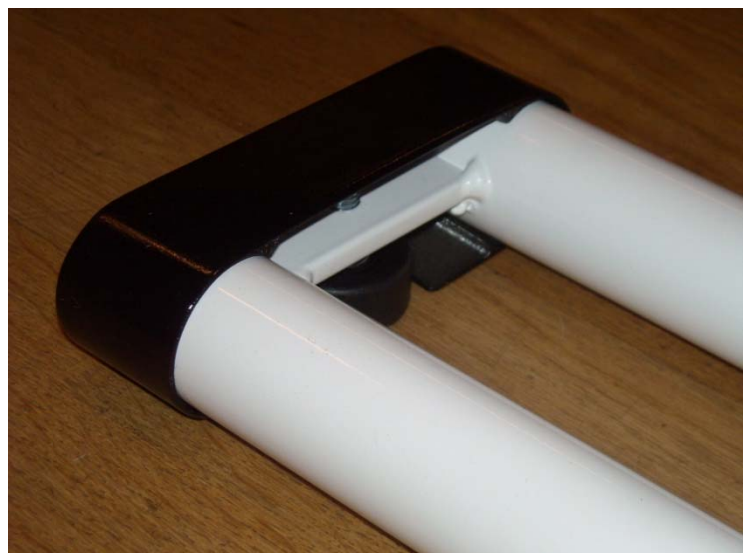
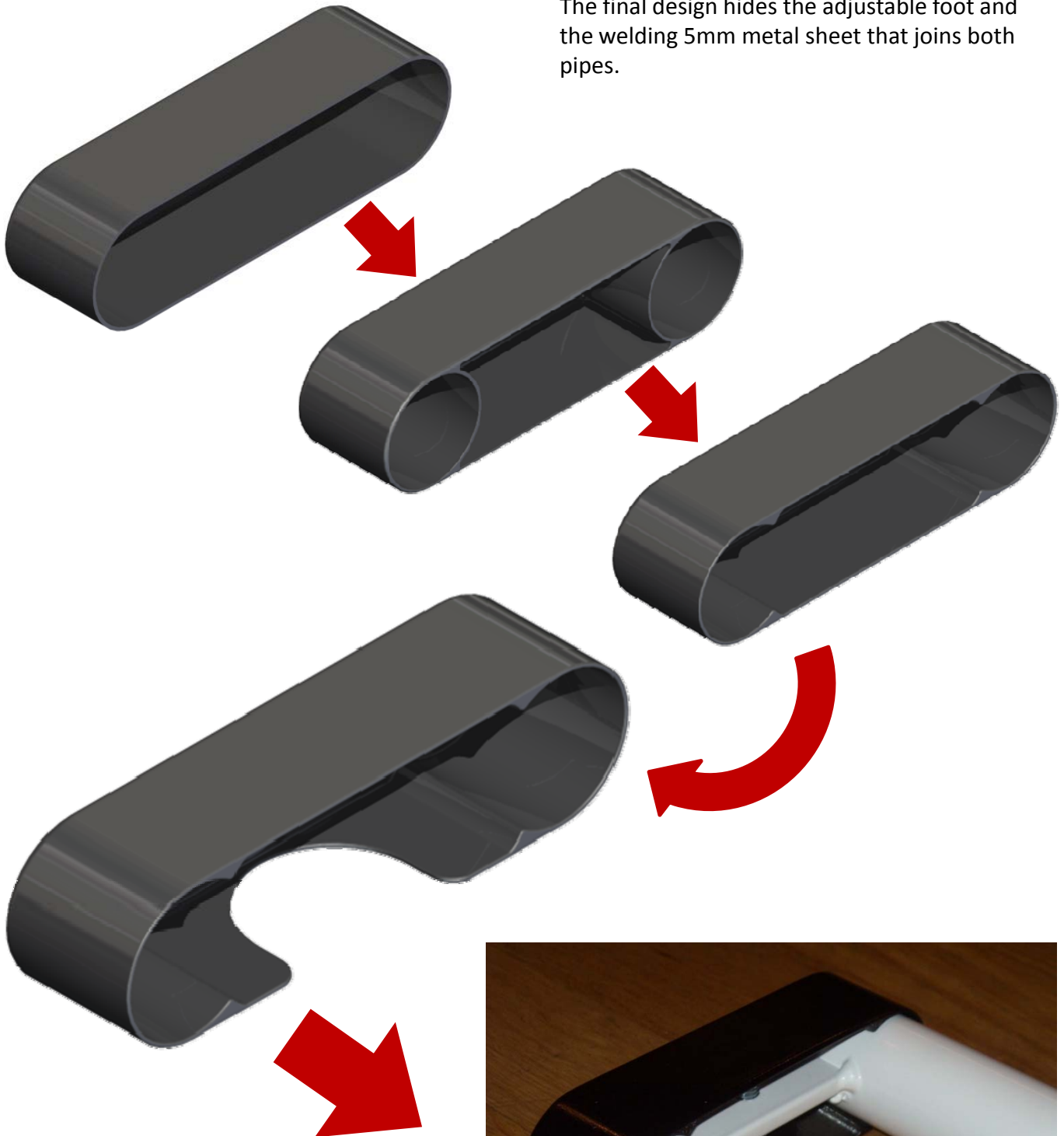

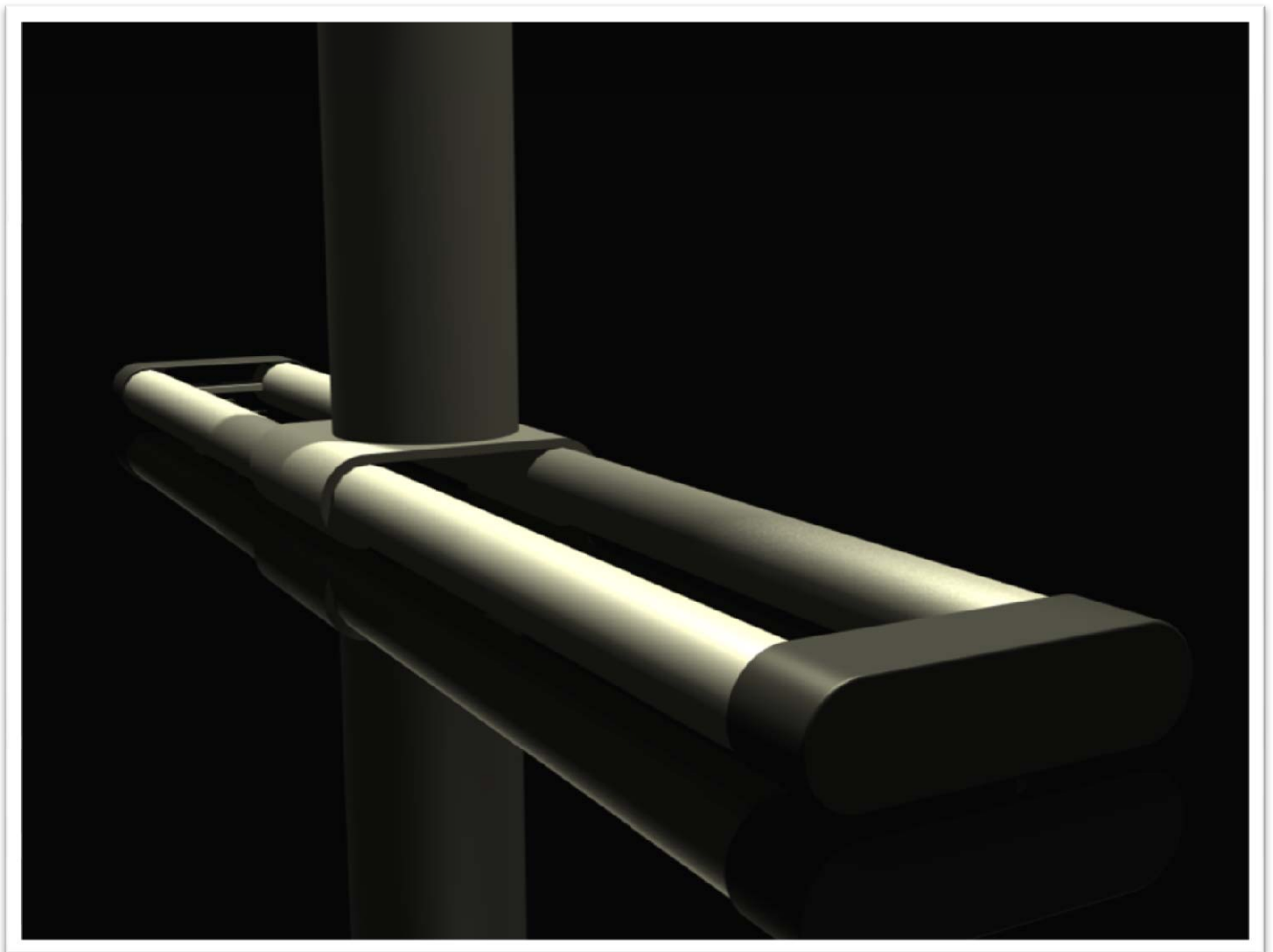





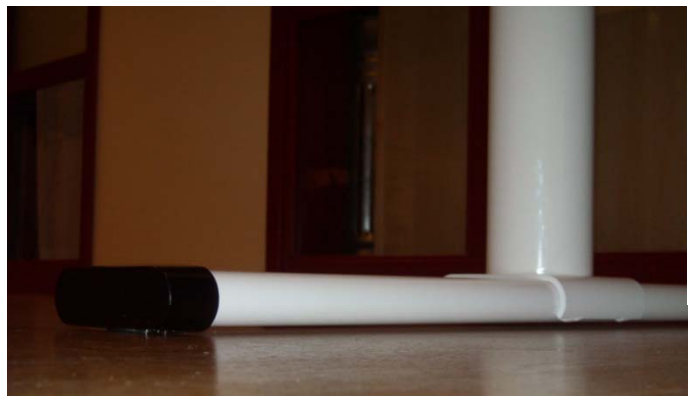
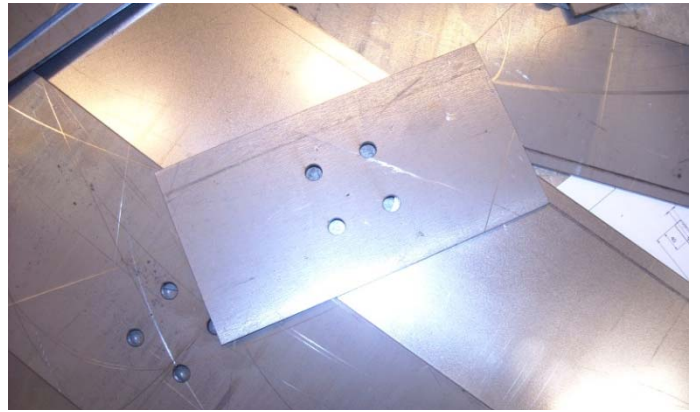

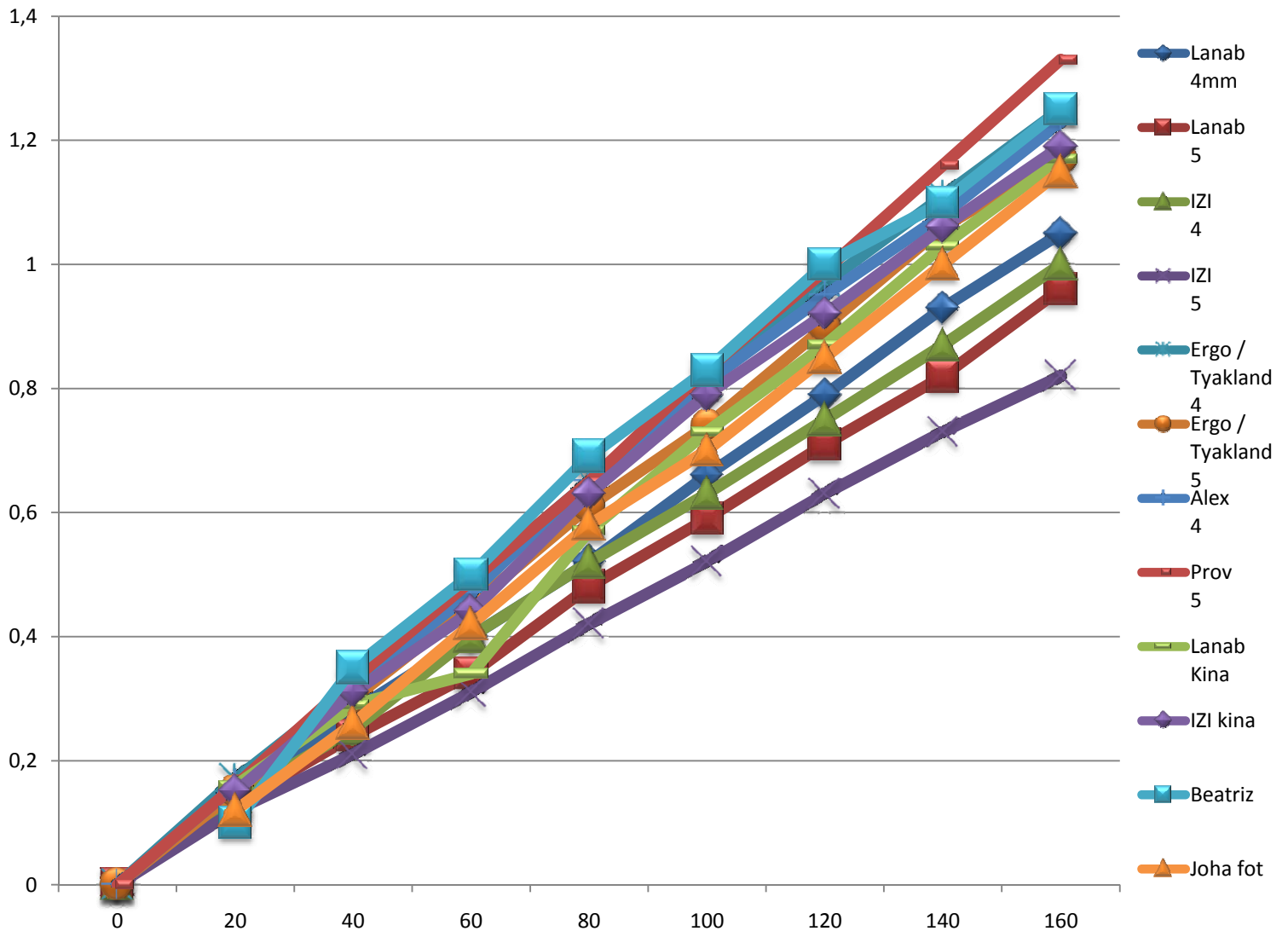

The stability analysis shows that the new foot is not the best one, but other factors need to take into account like thickness and weight.

Rol's feet are around 4-5kg weight and 4-5 mm thickness steel sheet.

The new foot, weights 2 kg and the pipes have 2 mm thickness. If the thickness of the pipes increases 1-2 mm, maybe the stability analysis would be better.

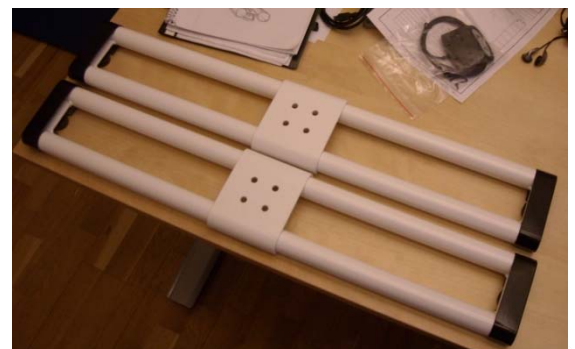
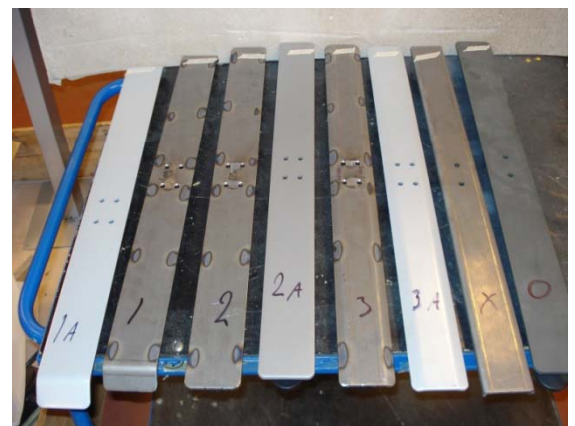



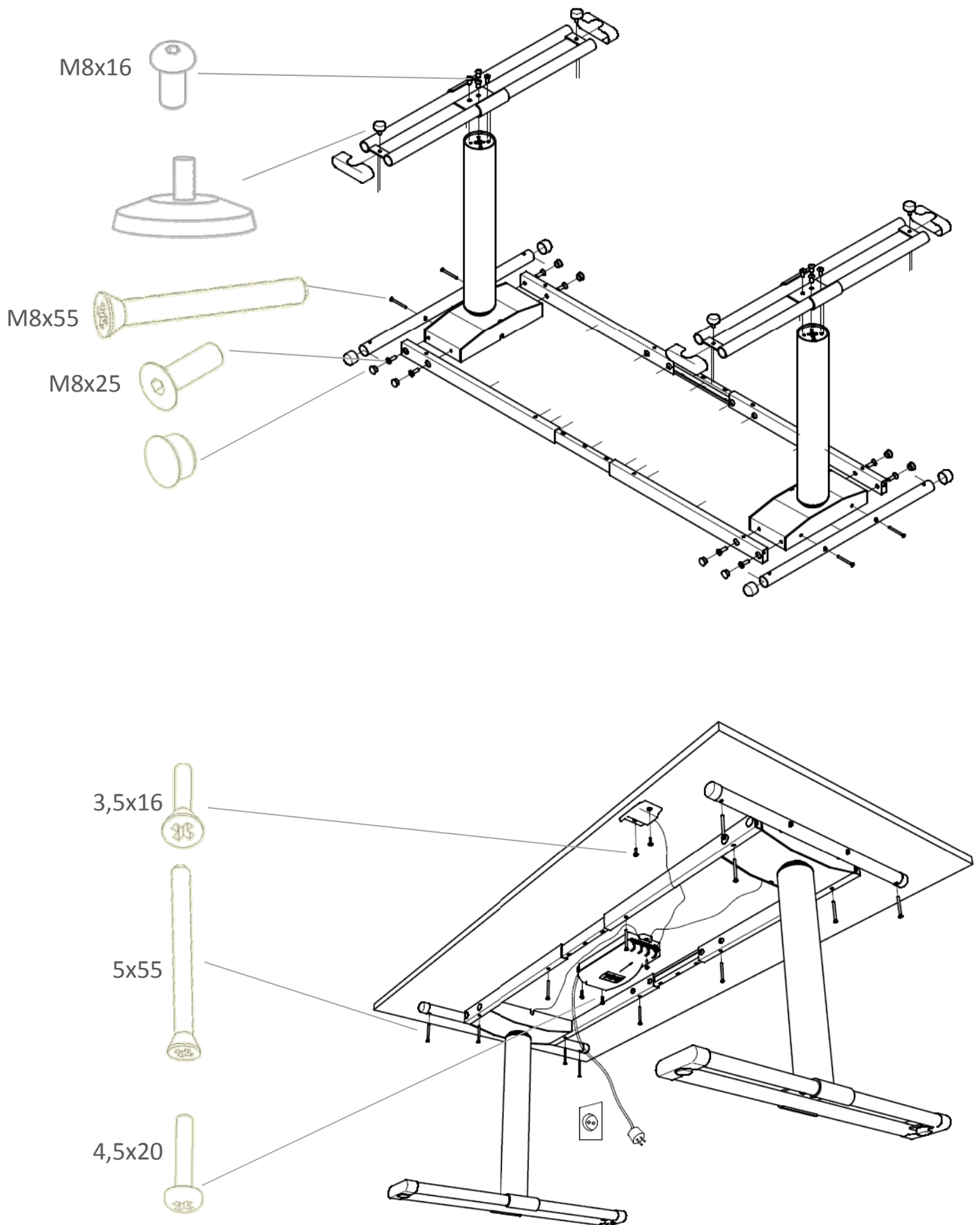

## *Appendix*

On September 17th, Dag Holmgren told me that he had found a project. This project would involve in designing a feet and sidebar for a height adjustable table. My first reaction was that I thought the project would be too easy and that I wanted something more complex. However, he told me that we should go through the company's installations and if that if I would not like any, he would look for another project.

On September 25<sup>th</sup>, we visited ROL. First we have been to *Axamo* to see the factory and the showroom. After that, we went to *Hovslätt* to see Rol Ergo. Mia told us about the ongoing project about designing new feet for height adjustable tables. Dag thought that it would be a good experience if I could do such project directly in Rol Ergo. Mia did not have any problems about it, and on September 28<sup>th</sup> I started the project in Rol Ergo.

Already in the company, my two first weeks were spent in drawing whichever related to table's feet. Mia did not put any restrictions as to product design, since she wanted to do something different. I got 25 ideas, divided into 6 groups: 1) Inspired by Rol's Feet; 2) Pipes; 3) Steel Bending; 4) Extendable feet; 5) Feet with wheels; 6) Functional feet.

On October 8<sup>th</sup>, we had the first meeting. Mia, Robert, Thomas and Dieter were there. At the end of the meeting we thought that the project would continue based on 3 different groups: 1) Inspired by Rol's feet; 2) Pipes; 3) Steel Bending - but this group would change to aluminium extrusion.

I started modelling sketches with *Inventor 10* program because this is used in Rol Ergo. I did not have a computer in Rol Ergo, so I used Mia's computer. After modelling the feet, I did renders to do the presentation on October 23<sup>rd</sup>, because Dag would come to that presentation. When Mia saw the renders, she wanted to go further on the designing of tables, but following Rol's tables characteristics. That way, I started to do a dossier with all the components that Rol Ergo had.

Next week, I had a computer and an office dedicated to myself. I felt like as if I was another member in the company. The problem was that the computer account did not have enough access to do the necessary product assemblies regarding Rol's components, and the problem was then solved after a week...

Week 44 was great. On October 27<sup>th</sup> I went to see my first hockey match with Robert. It was an incredible experience. *HV71* played against *Rögle BK*, and Jönköping's home team won 5-3. The following day we went to university for a meeting with Dag Raudberget, Mia's teacher, to present prototype machine that is capable of developing specific shapes regarding the user's specific input characteristics, and after I have told him that I would want to develop the components related to the tables feet would be done in ABS.

Next week was the Spanish Cultural Day and it was the same day Dag Raudberget was going to give me the plastic pieces I needed for continuing my works related to the development of the feet prototype. I could not go to Rol Ergo, so I told Mia and Robert to come to Student Hus to taste Spanish food. They have accepted my invitation and after some time they arrived at the event. What they liked most was a desert called *Torrijas*.

On November 11<sup>th</sup> was Elmia Subcontractor's visit. It is a fair where most of Swedish companies related to the industry segment, and some from other countries presented their products and

services. I stayed all the day with Thomas and I understood how Swedish people work. During the morning I told Thomas: *"Today we have holidays "*, and he replied; *"no, today is a hard day, I have to work more than the rest of the days"*. This proved to be true. We did not stop during all day, visiting expositions and talking to people.

On 19<sup>th</sup> of November Mia, Robert , Thomas and me went to see two companies. One worked with plastic components and the other one was Sapa, the company that Dag told us about. A man show us the company, their history and the manufacturing processes. Incredible. At the end of the day, I show him the profiles I had for doing an aluminium foot and he told us he would send a draw with the profile that he thought will be better.

Next day, Thomas (and me) started to do one of the prototypes. Mia had ordered *Axamo* steel sheets that would be cut by laser and that we have already had the plastic pieces, so we would only had to curve one piece and then weld the pipes. After doing the stability measurements, Mia sent the feet to the painting factory. I wanted the feet in chrome, but Thomas told me that it would be too expensive and that in white, grey or black would be cheaper. So, we painted the horizontal components in black colour (frame, feet endings and glides) and the vertical in white (legs and feet).

Next, on the following weeks, these were spent on developing the feet, doing more drawings, modeling ROL's table components and doing assembly instructions for the company. I started writing the report and doing renders for the presentation.

On December 11<sup>th</sup>, Dag came again to ROL Ergo to see how the project would be presented on next Friday. He have told me that the dossier was good, but that I could attach the documents I have developed for ROL, and that were not from the same project. He asked me for telling my feelings about the project and to be part of a company.

Most important of this was that the project has not been the feet or sidebar design, but that the most important that it has been based on the working relationship between people and how they have related with me. I have felt like been part of a big family and I have felt that my education have served for a purpose, considering this experience. From what I have learned, there are more details involved in designing products than just measuring shapes and components necessary for the development of a required product, but that my personal in-company experience results from this practical learning experience, I could not measure it in words...

The opportunity to be every day in the company and, seeing their problems, and how these are solved, its the best result from it.

I recommend it for future students.

Thank you very much.

*Tack så mycket.*

# Stand ED 500 Rect

**ROL | ERGO**

30204315

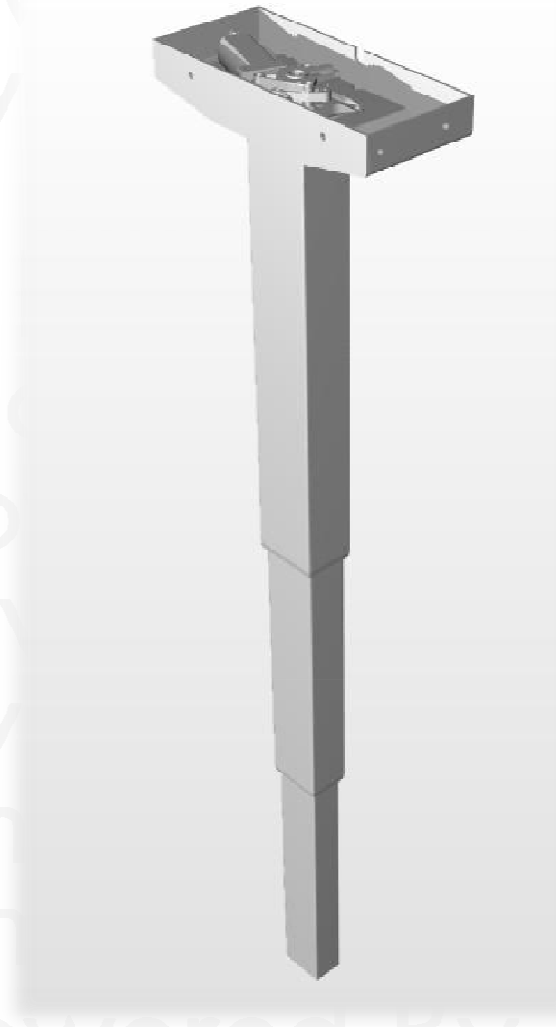
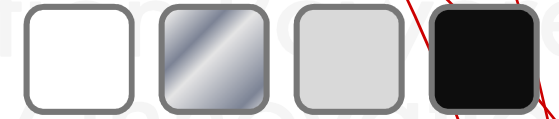

Feet

30205392

30202713

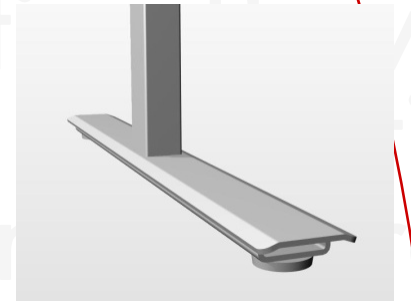
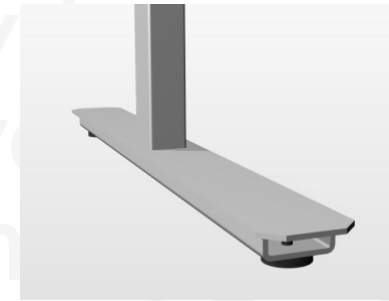

30204588

30203183

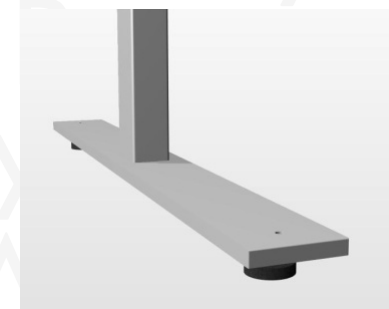

Frames

Sidebar

30205280

30204468

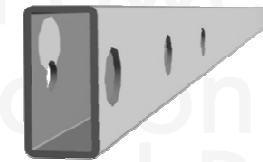

30205020

30204860

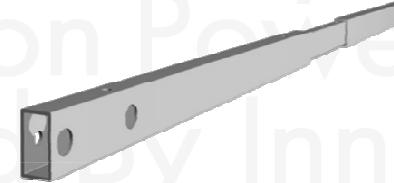

68000185

68000255\*

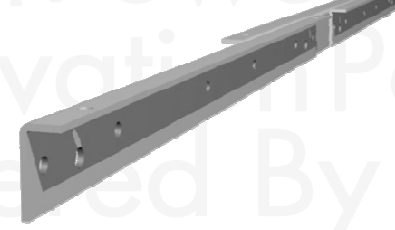
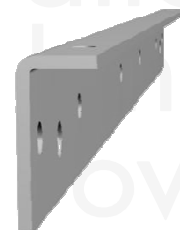

30202078

30201599

30202078

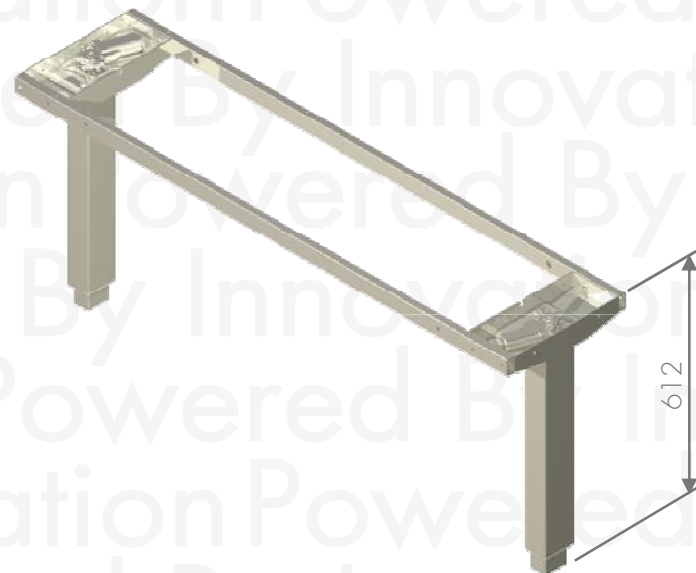
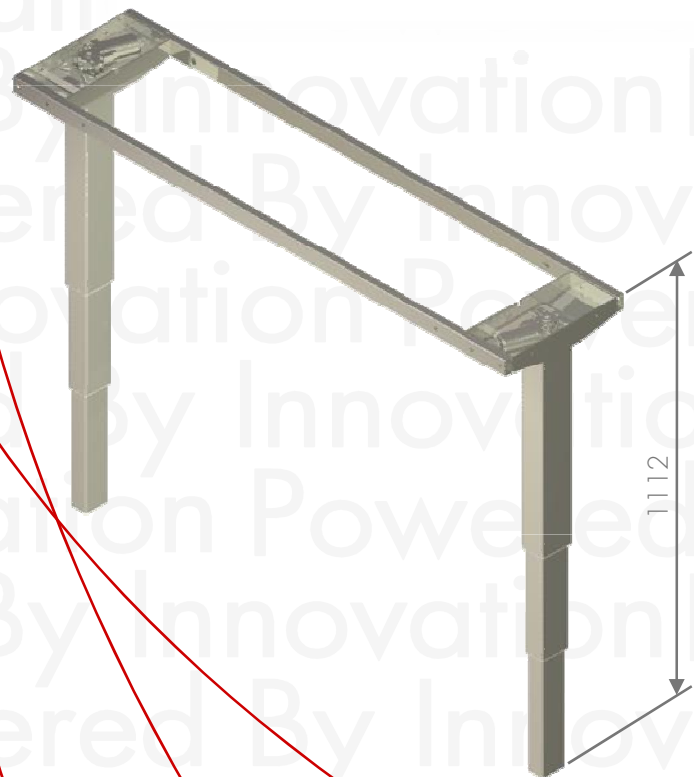
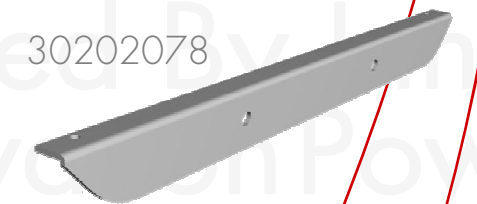

Powered By Innovation



# Stand ED 650 Rect

# ROL | ERGO

30204364

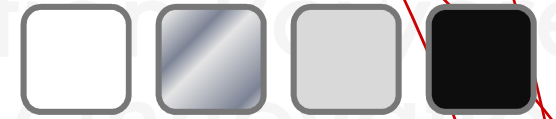

Feet

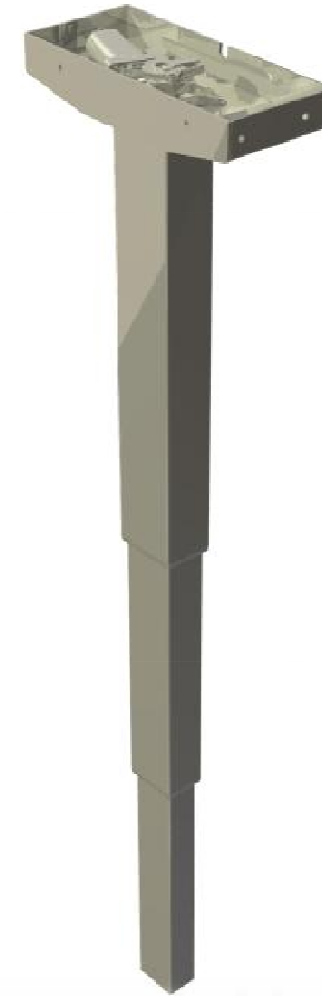

30205392

30202713

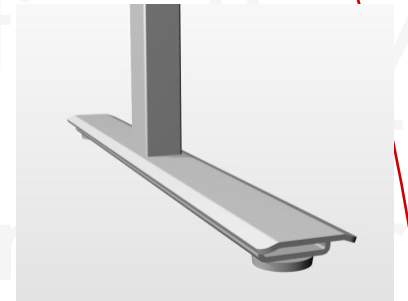
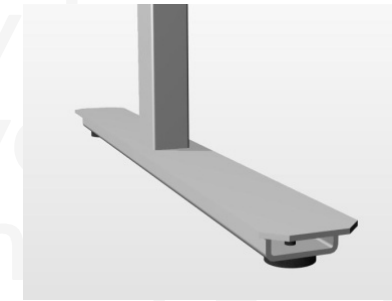

30204588

30203183

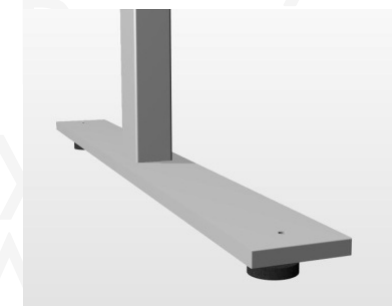

Frames

Sidebar

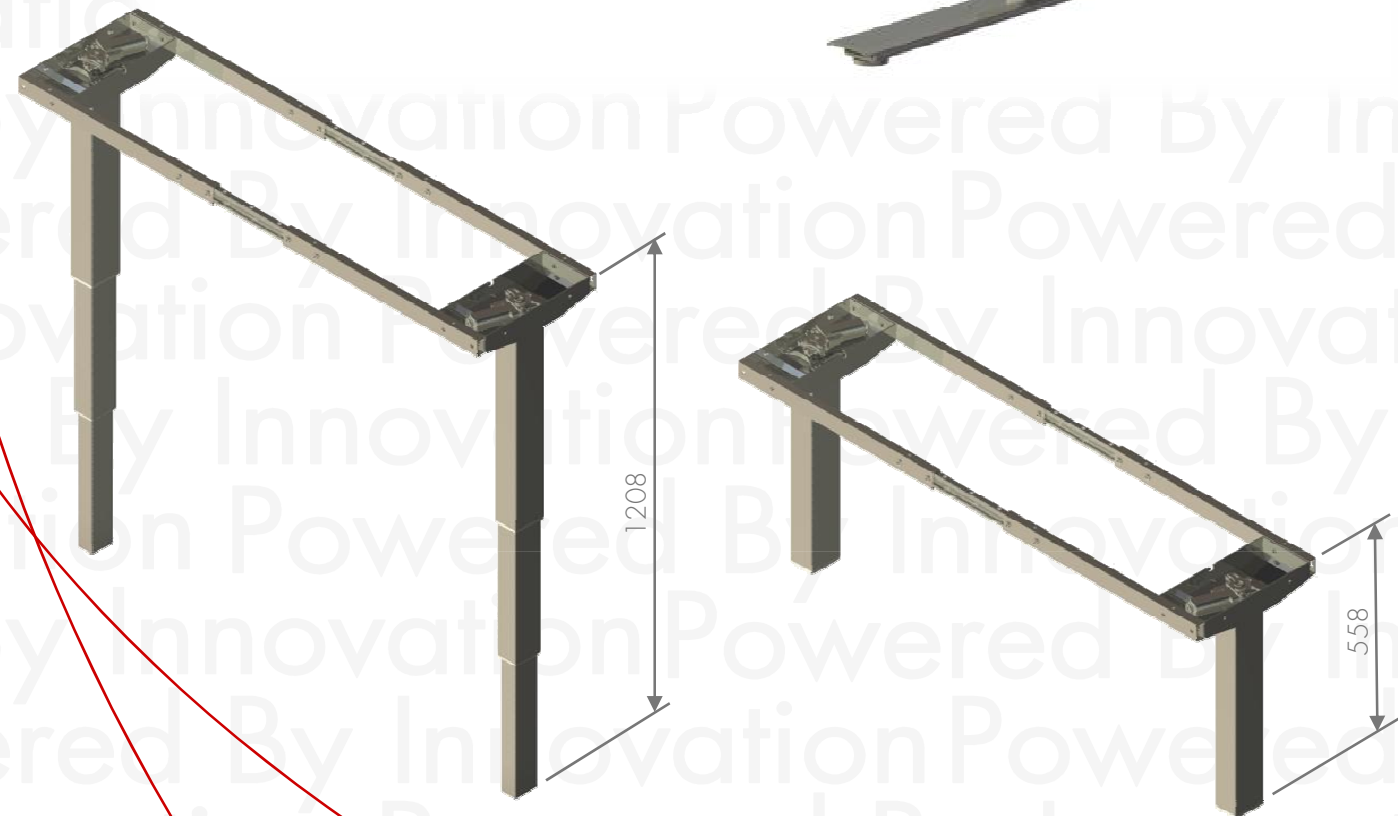

30205280

30204468

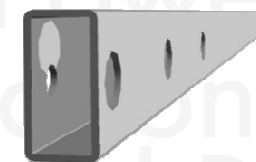

30205020

30204860

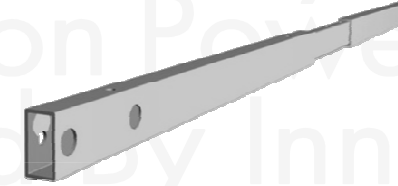

68000185

68000255\*

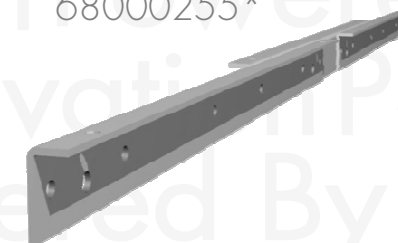
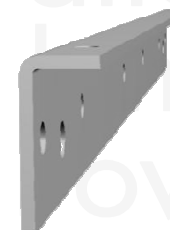

30202078

30201599

30202078

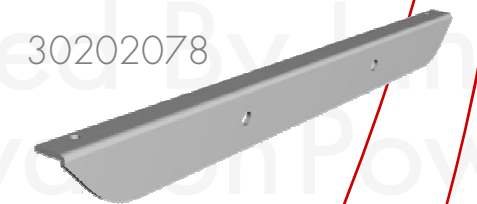

Powered By Innovation

[2009-11-12]



# Stand ED 500 Round

**ROL | ERGO**

30204344

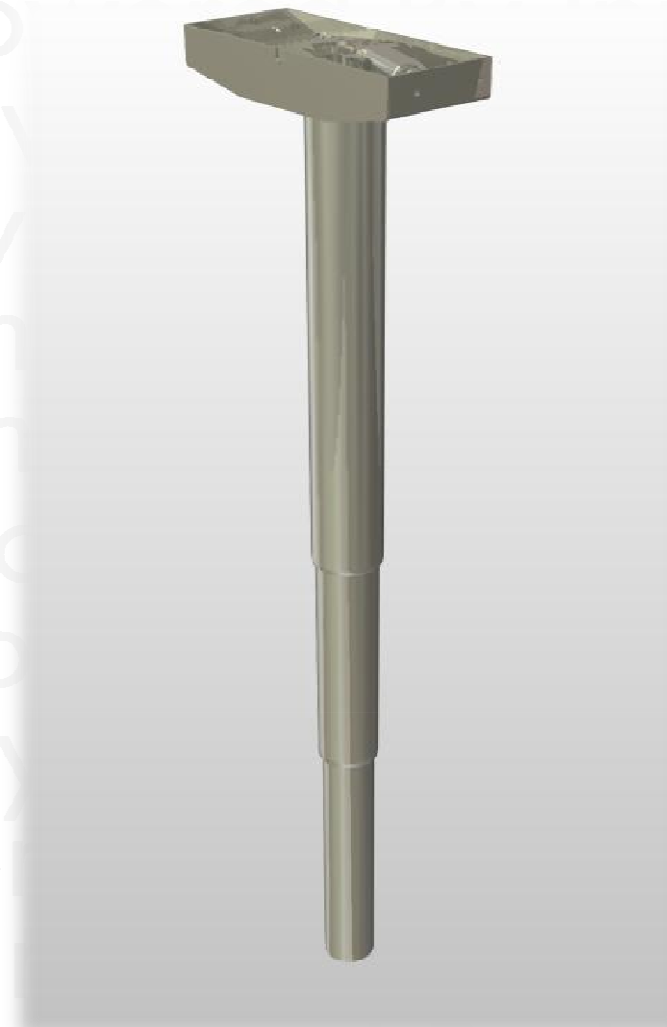
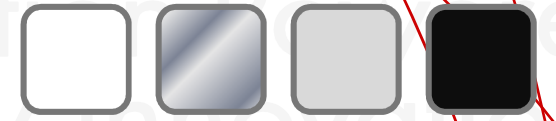

Foot



30205599

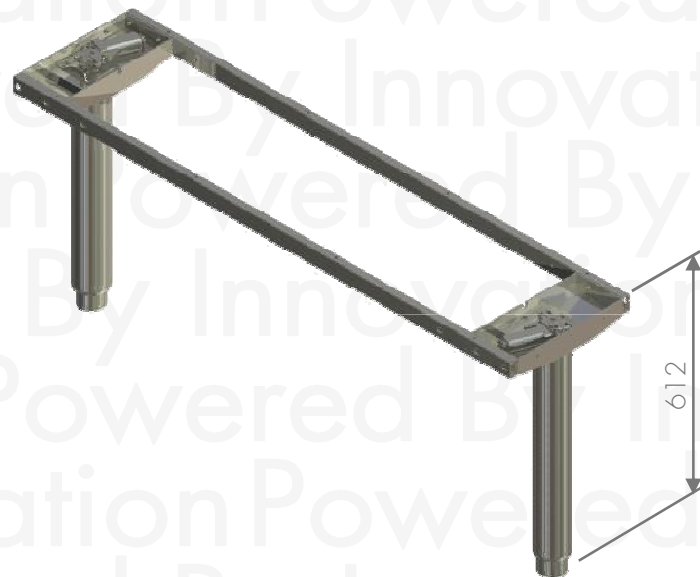
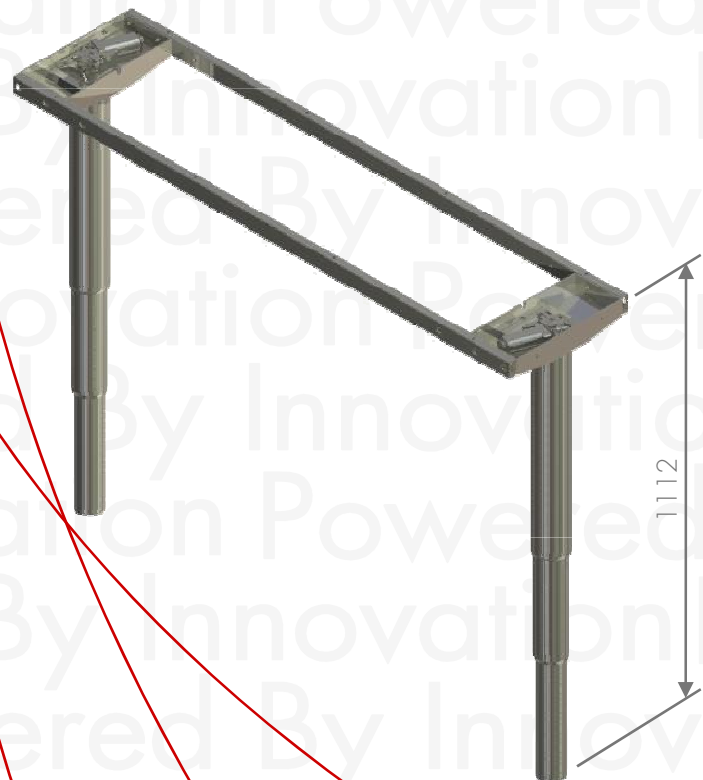

Frames



Sidebar

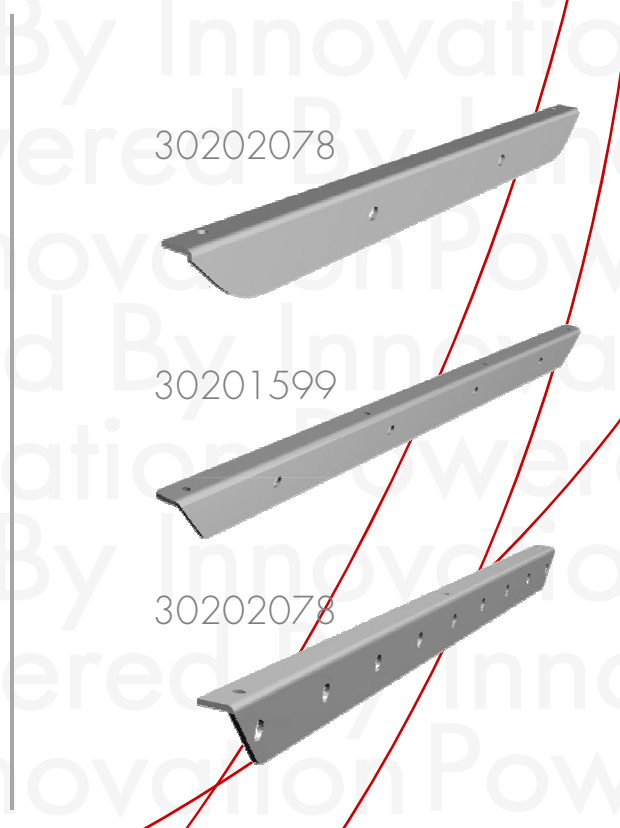

Powered By Innovation

# Stand ED 500 Round

# ROL | ERGO

30204303

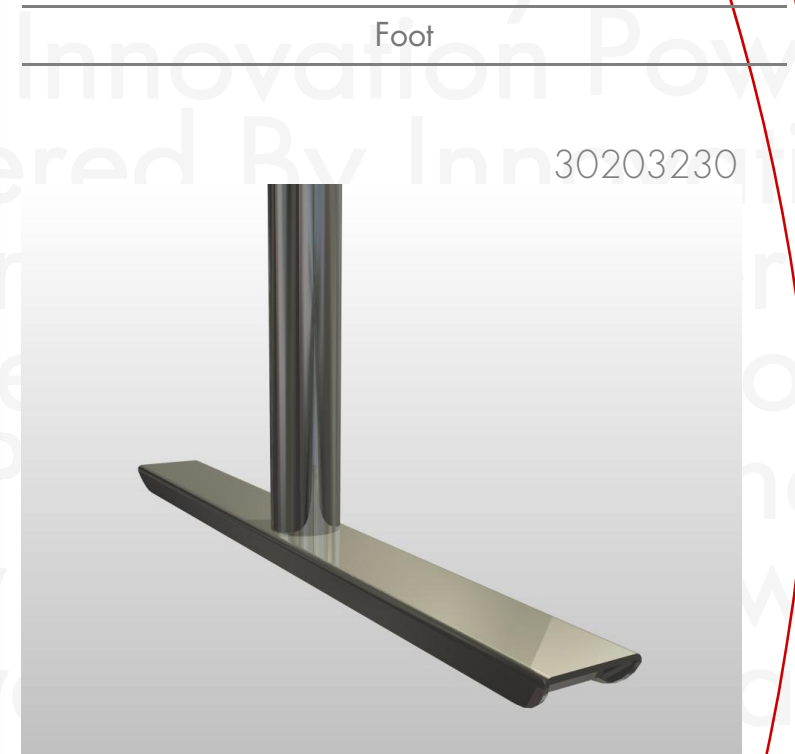
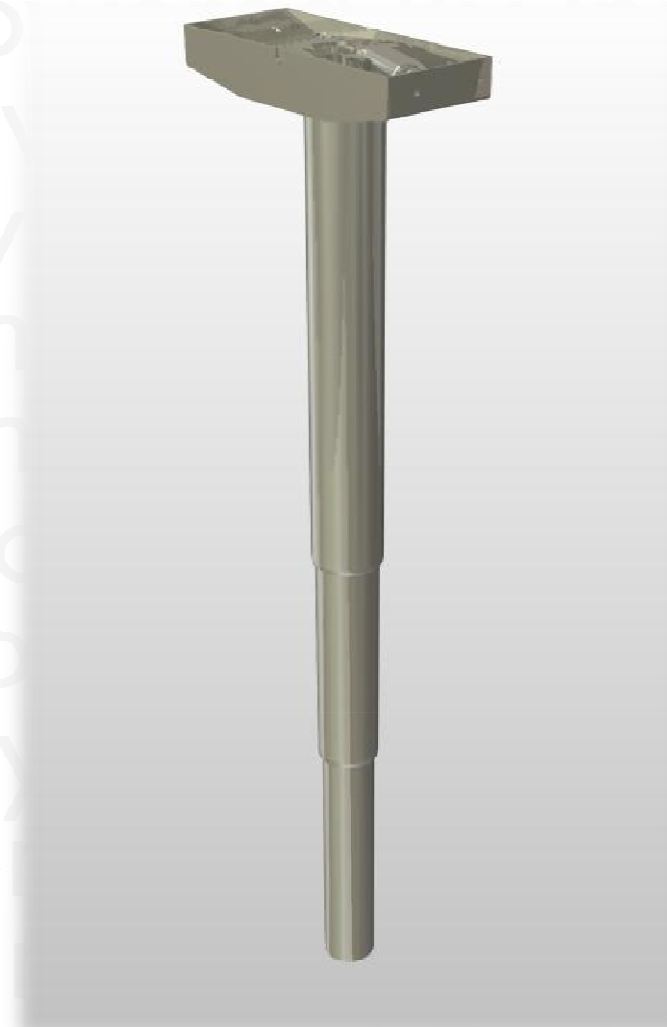
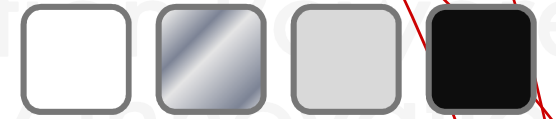

Foot

30203230

Frames

Sidebar

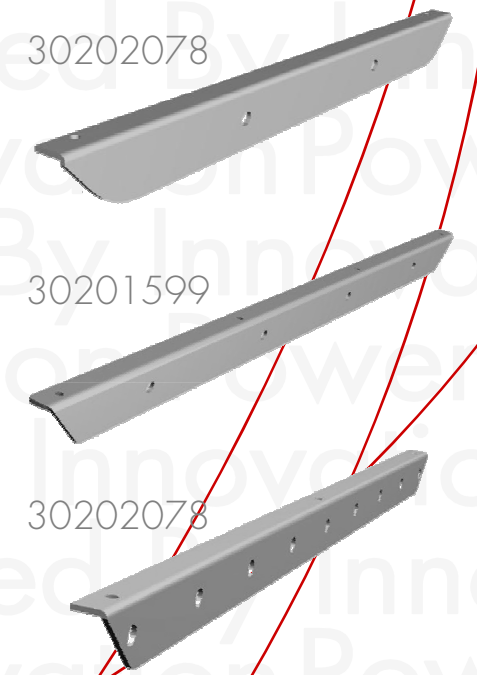
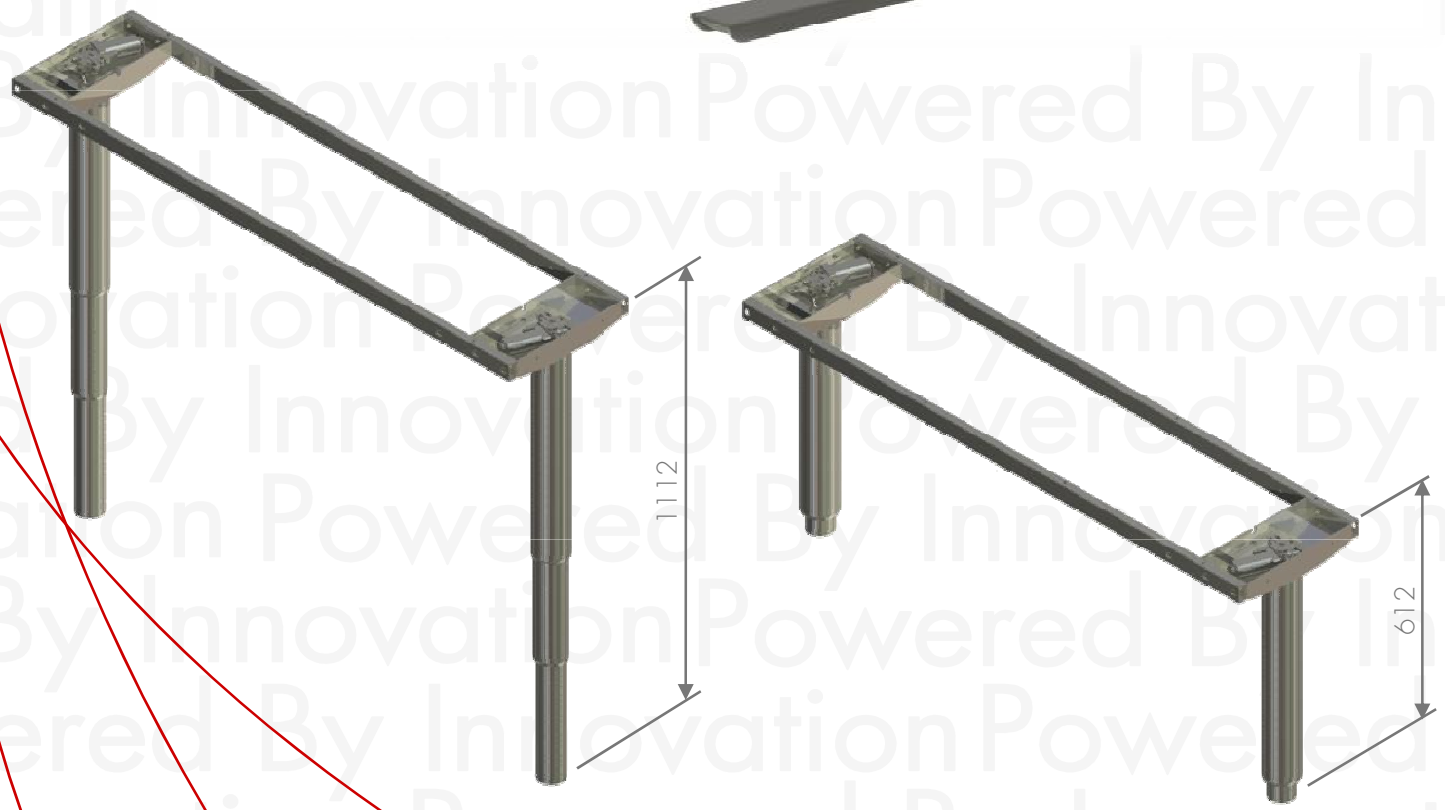

Powered By Innovation

[2009-11-12]

# Stand ED 650 Round

# ROL | ERGO

30204327

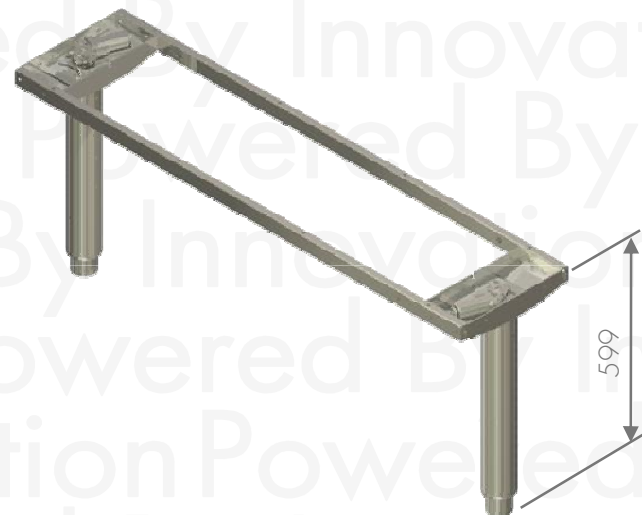
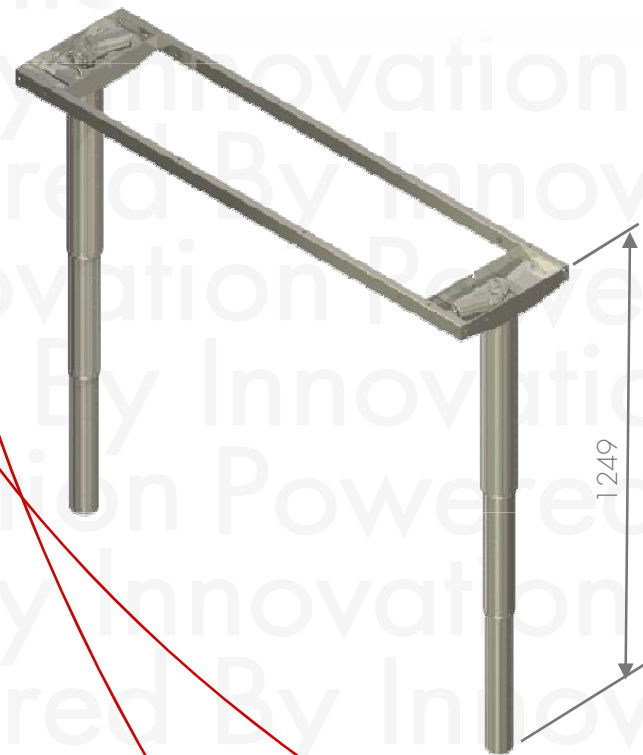
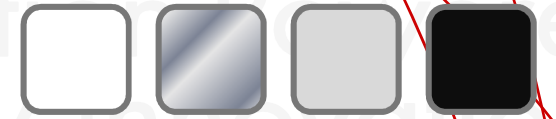

Frames

Sidebar

30205280



30204468

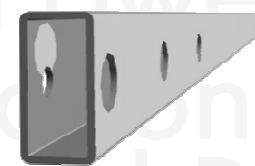

30205020



30204860

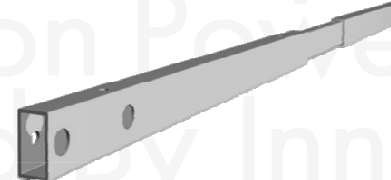

68000185

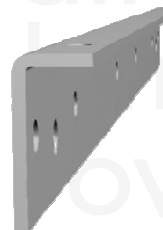

68000255\*

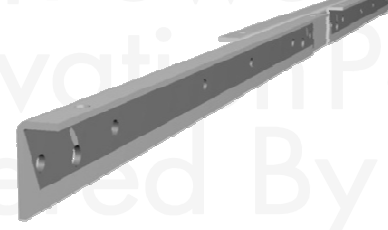

30202078



30201599

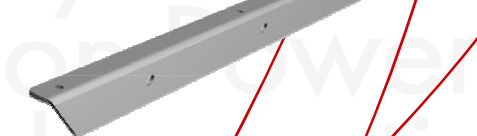

30202078

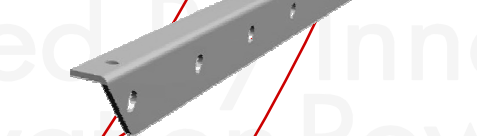

Powered By Innovation

[2009-11-12]



# Stand ED 650 Round

# ROL | ERGO

30204816

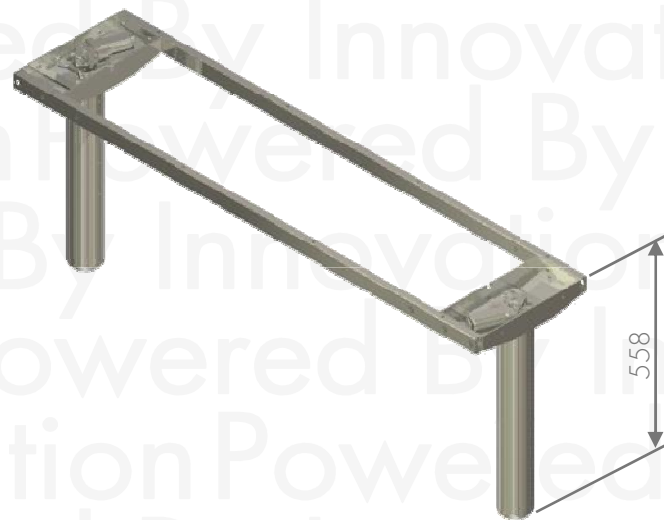
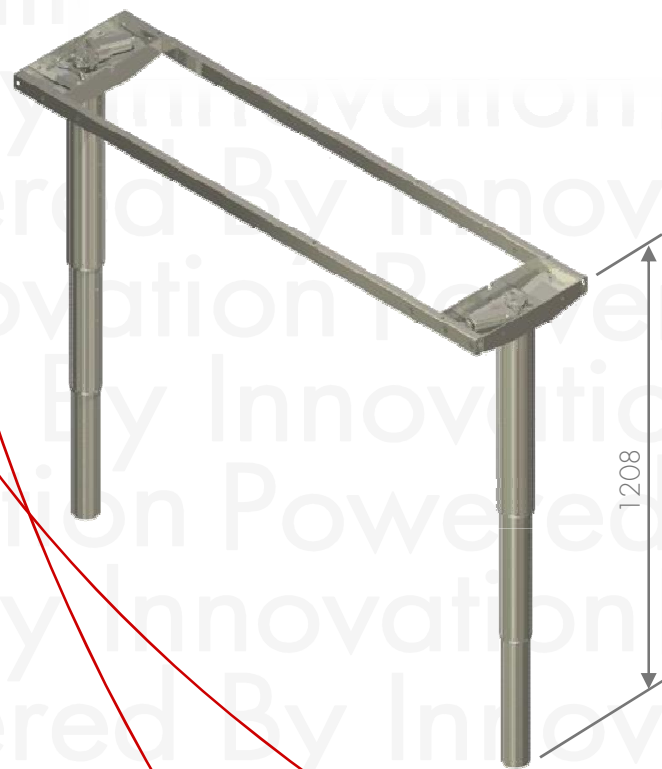
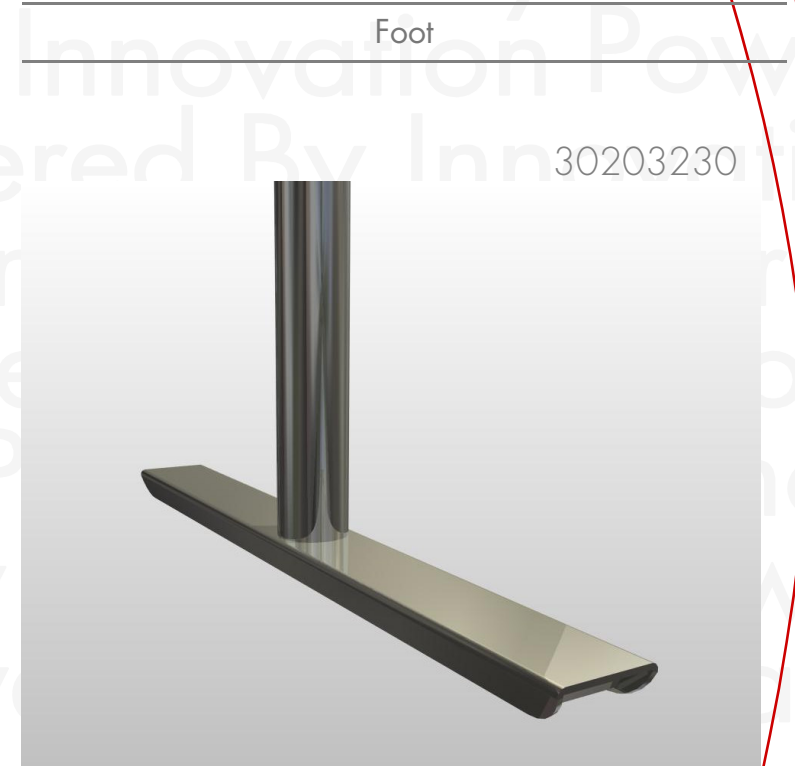
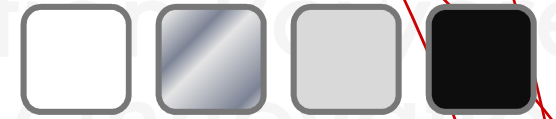

Frames

Sidebar

30205280



30204468

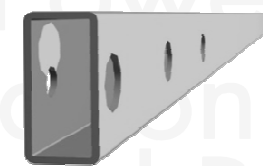

30205020



30204860

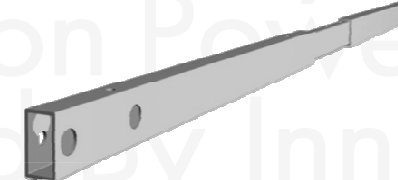

68000185

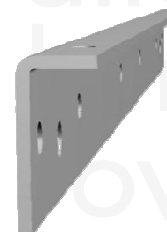

68000255\*

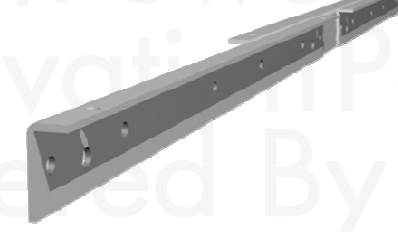

30202078



30201599

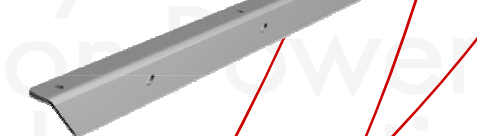

30202078

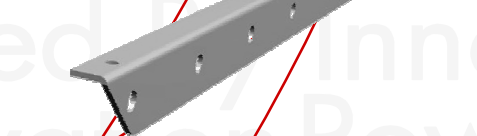

Powered By Innovation

[2009-11-12]

# Stand ED USD 650 Rect

# ROL | ERGO

68000161

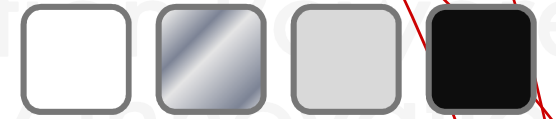

Feet

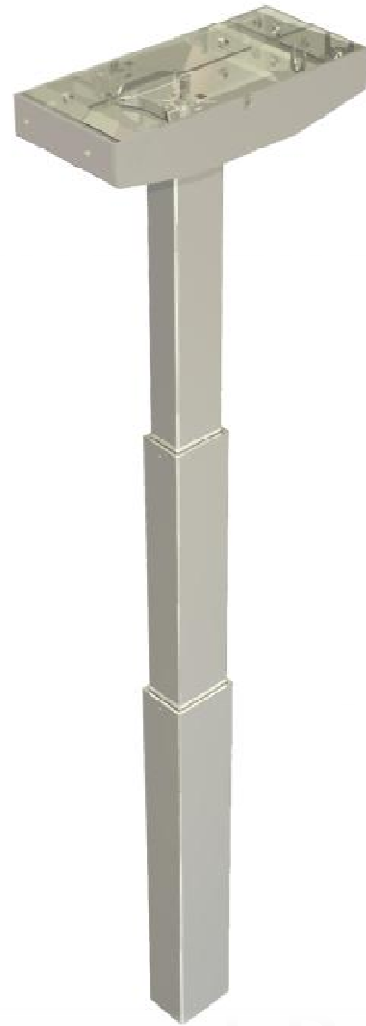

30204588

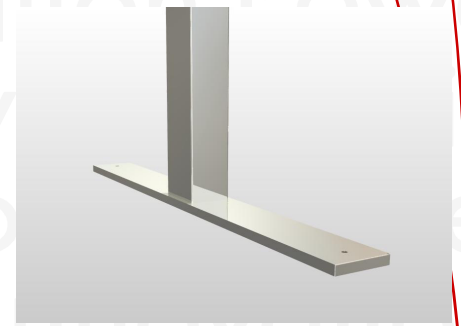

30203467

30203183

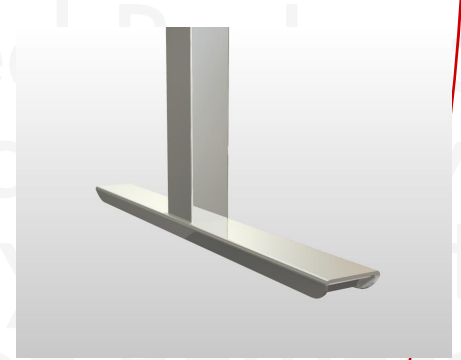

Frames

Sidebar

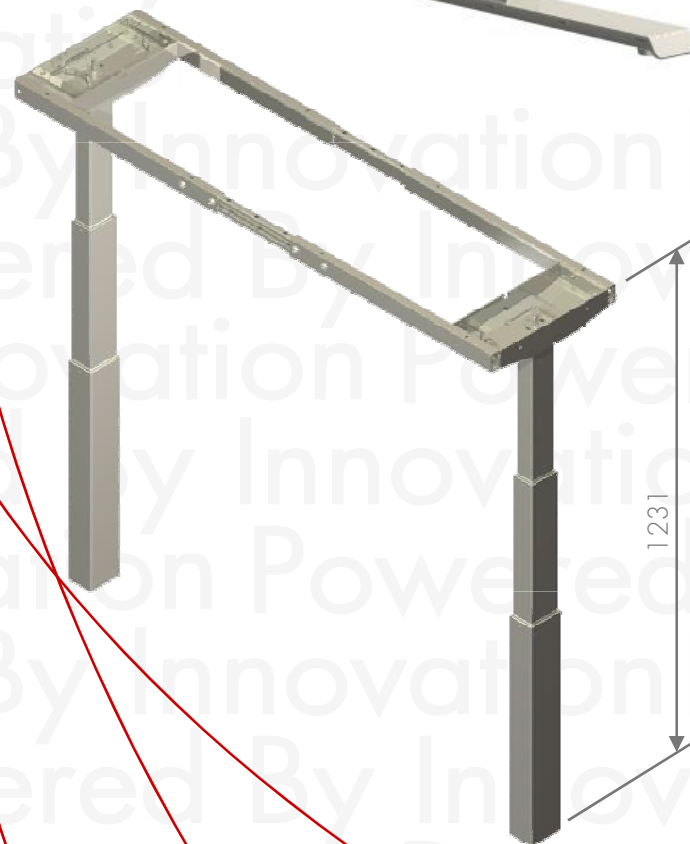

1231

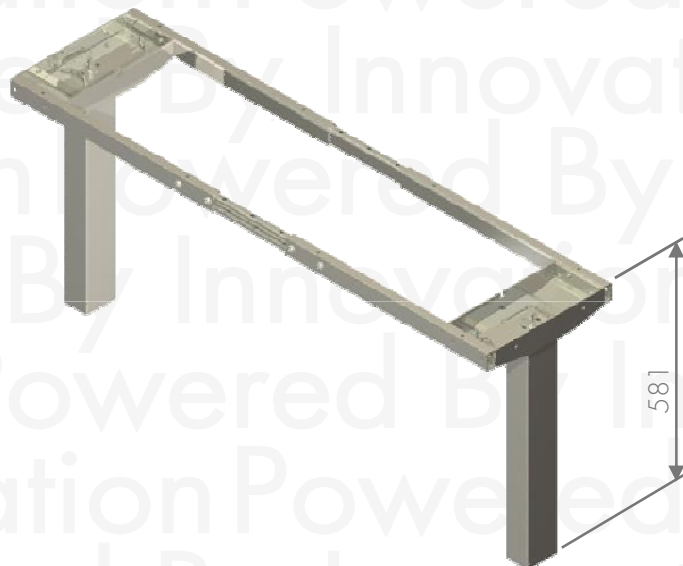

581

30205280



30204468

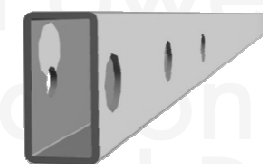

30205020



30204860

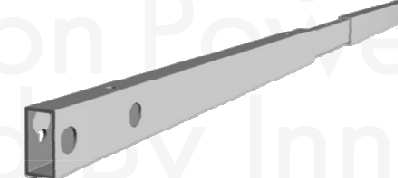

68000185

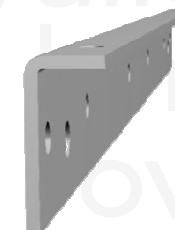

68000255\*

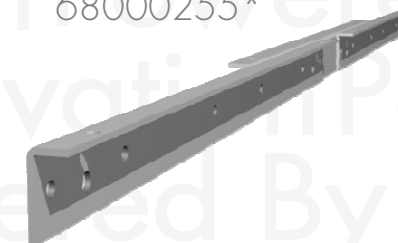

30202078

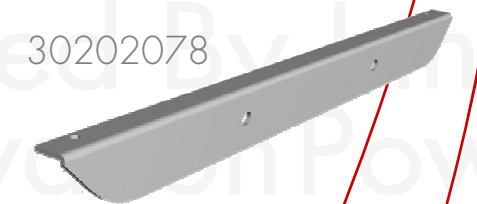

30201599



30202078



Powered By Innovation

[2009-11-12]

# Stand 470 Rect

# ROL | ERGO

30205163

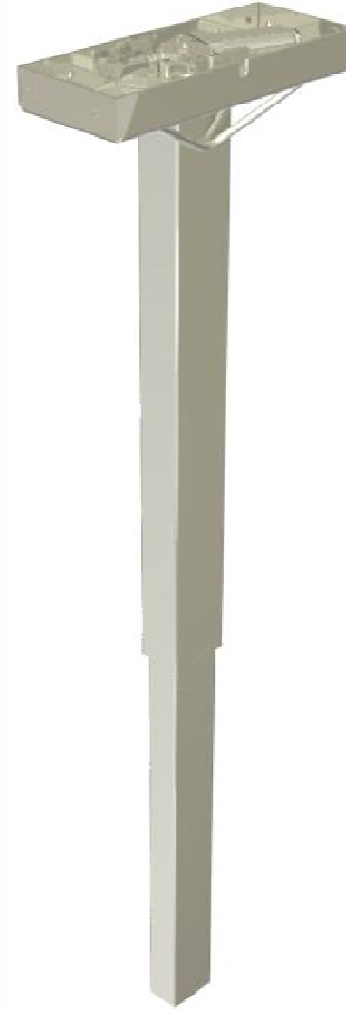
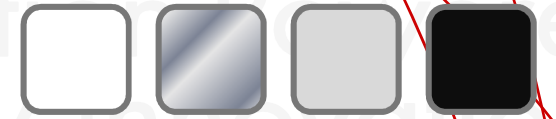

Foot

30203183



Frames

Sidebar

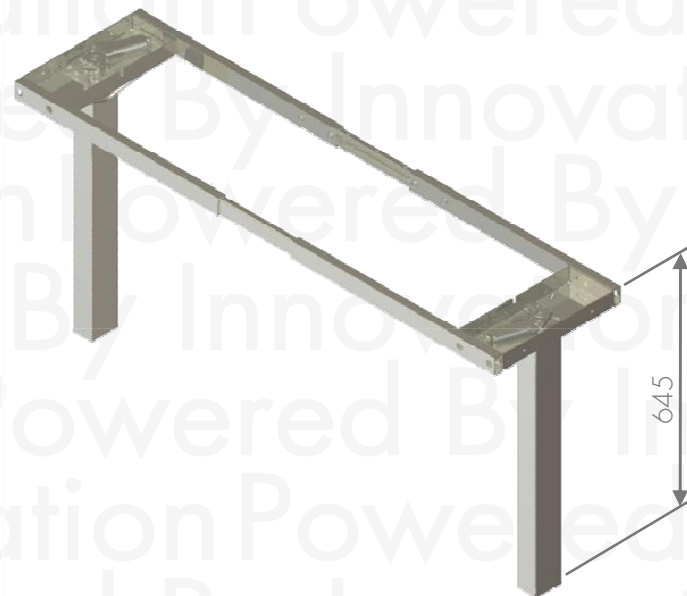
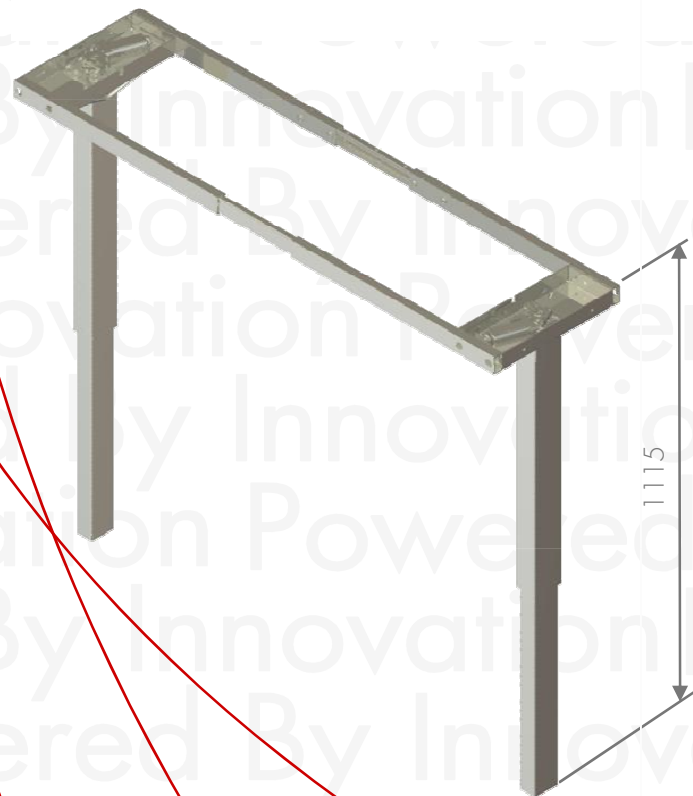

30205280



30204468

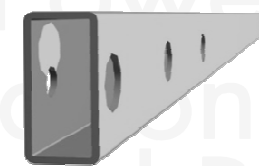

30205020



30204860

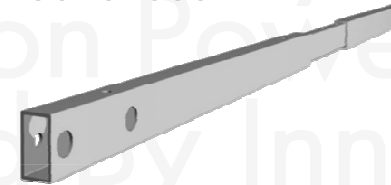

68000185

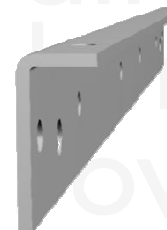

68000255\*

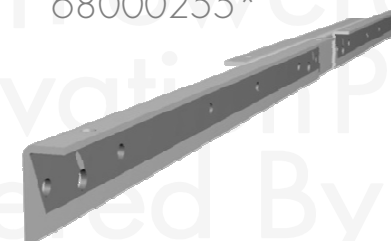

30202078

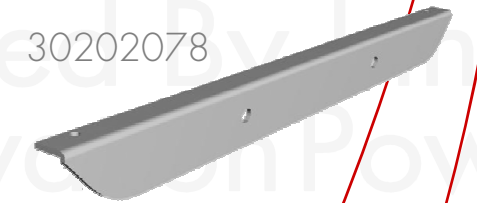

30201599



30202078

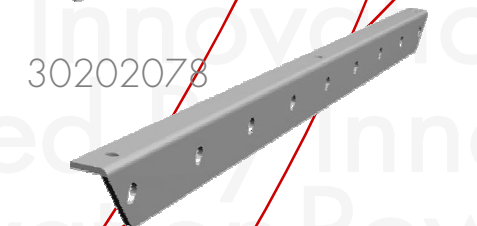

Powered By Innovation

[2009-11-12]



# Stand SingleDrive 470 Rect

**ROL | ERGO**

68000255 (68000245)

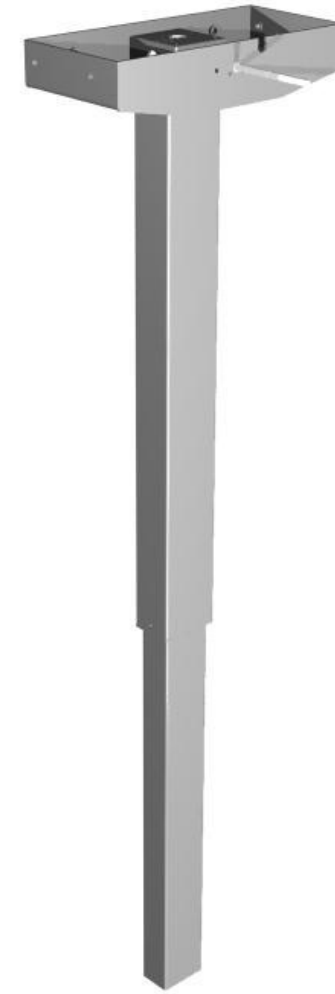
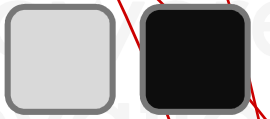

Foot

68000250

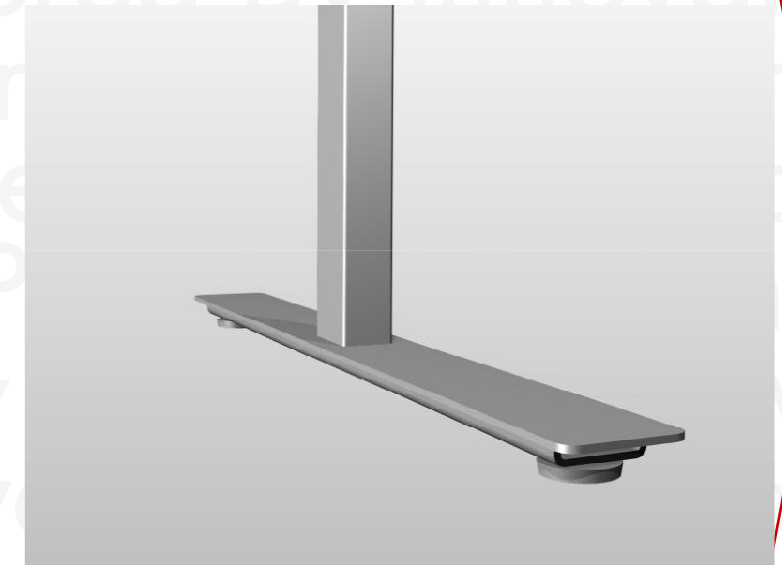

Frames

Sidebar

30205280



30204468

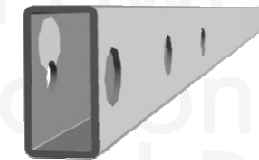

30205020



30204860

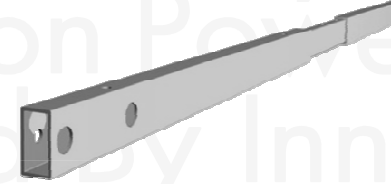

68000185

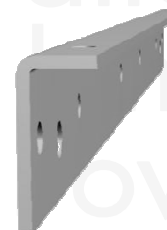

68000255\*

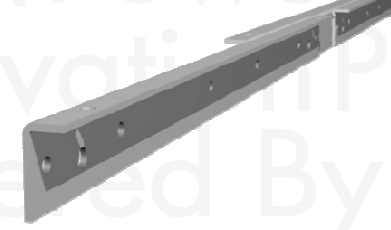

30202078



30201599

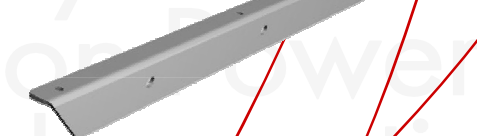

30202078

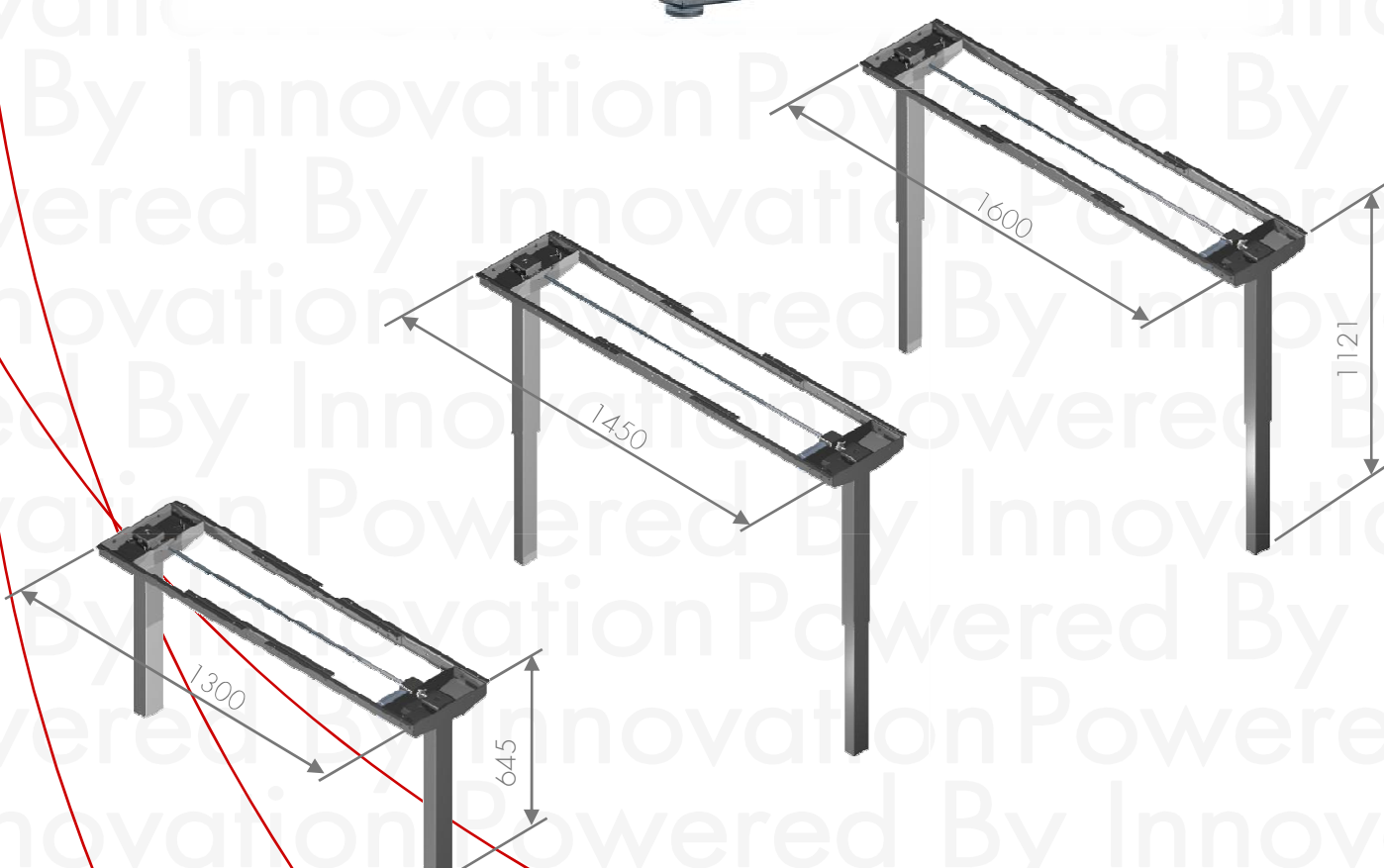
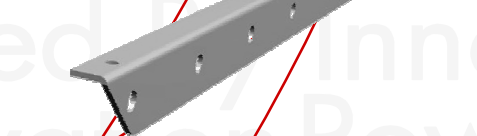

Powered By Innovation

[2009-11-12]

# Stand SingleDrive 470 Rect

**ROL | ERGO**

68000255

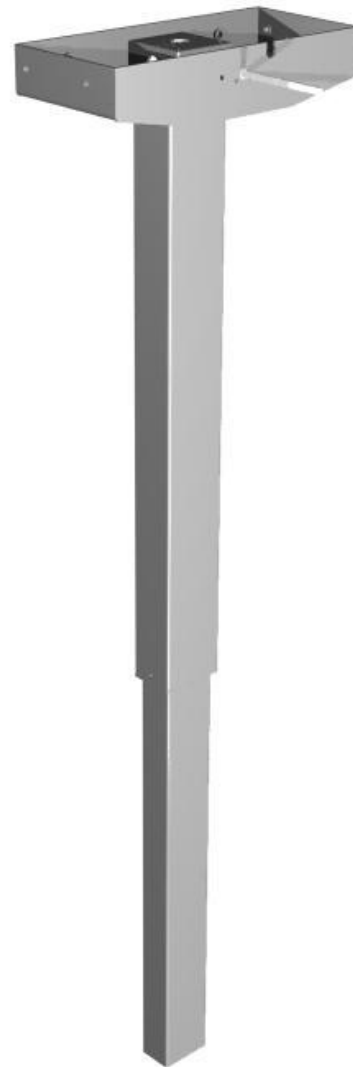
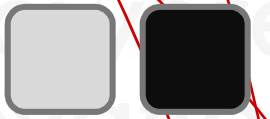

Foot

68000250



Frame

68000185

68000255\*

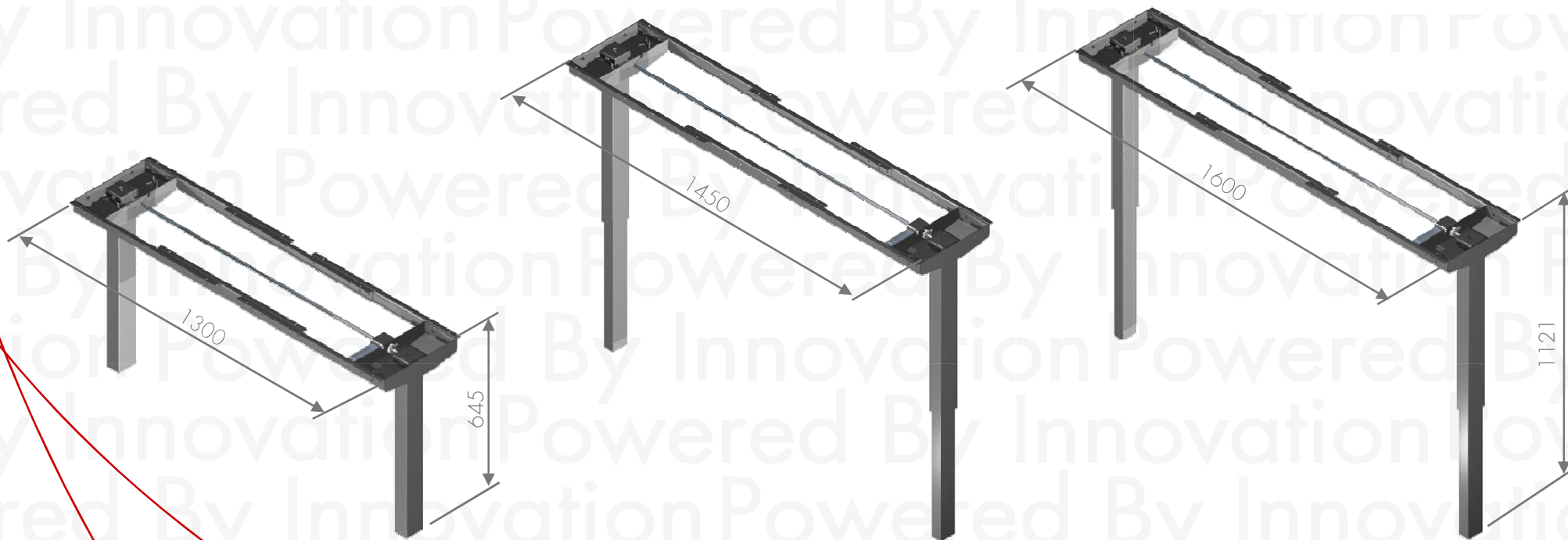
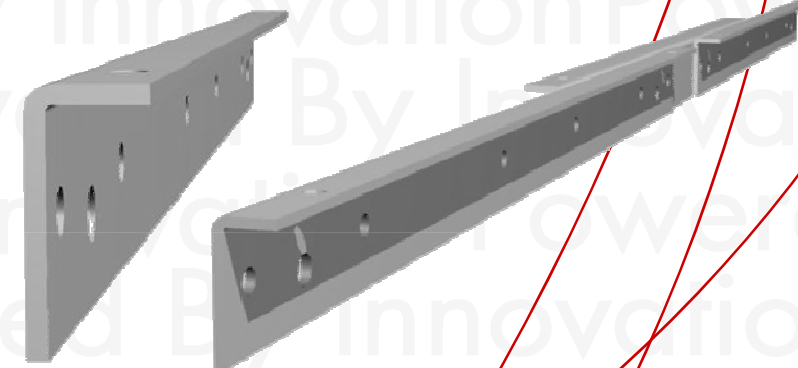

Powered By Innovation

[2009-11-12]

# Stand ED Crank Round

**ROL | ERGO**

30204740

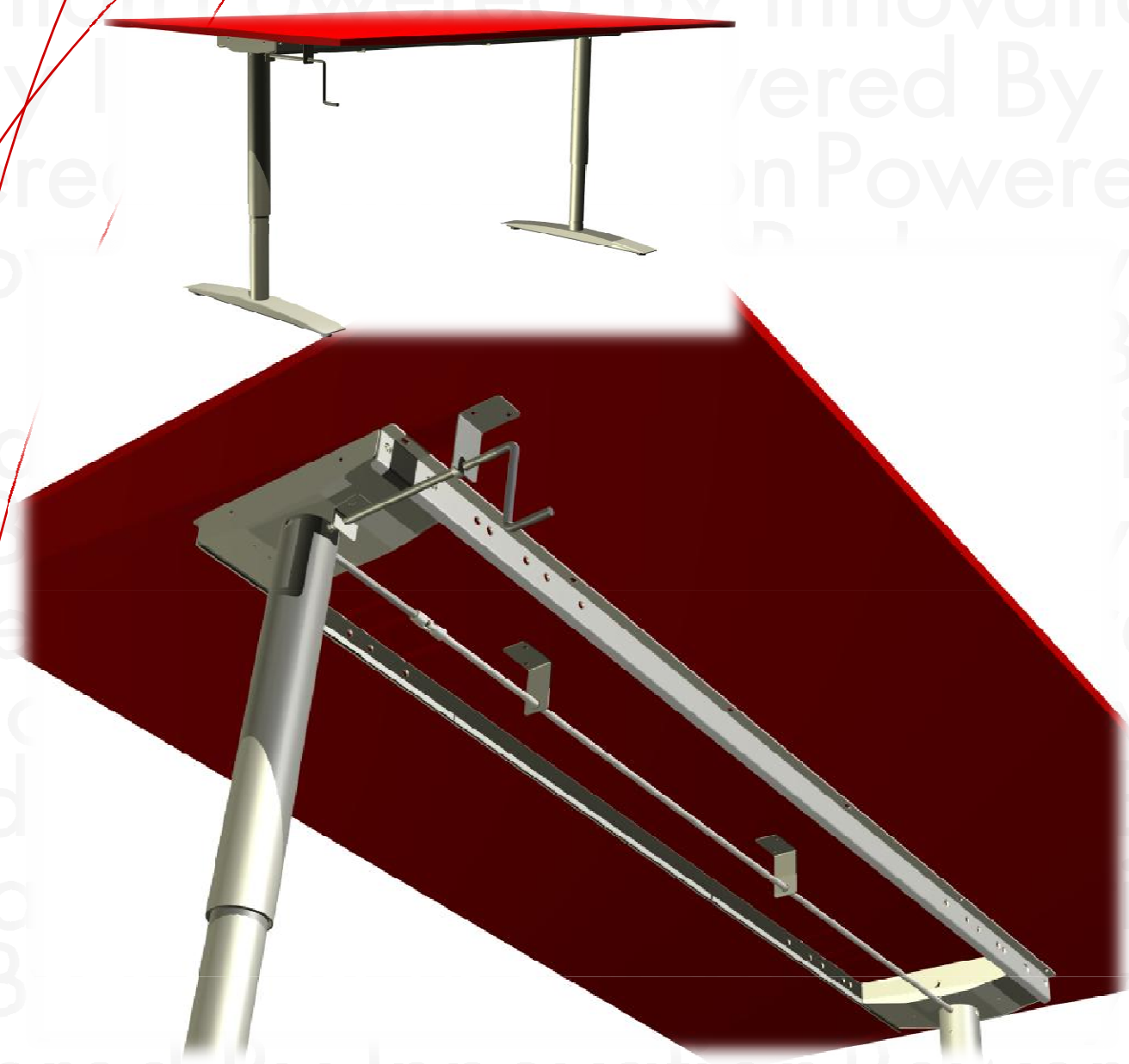
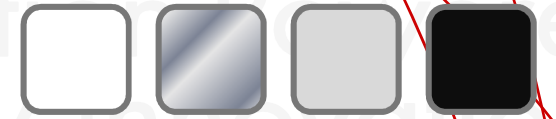

Foot



30205599

Frames      Sidebar

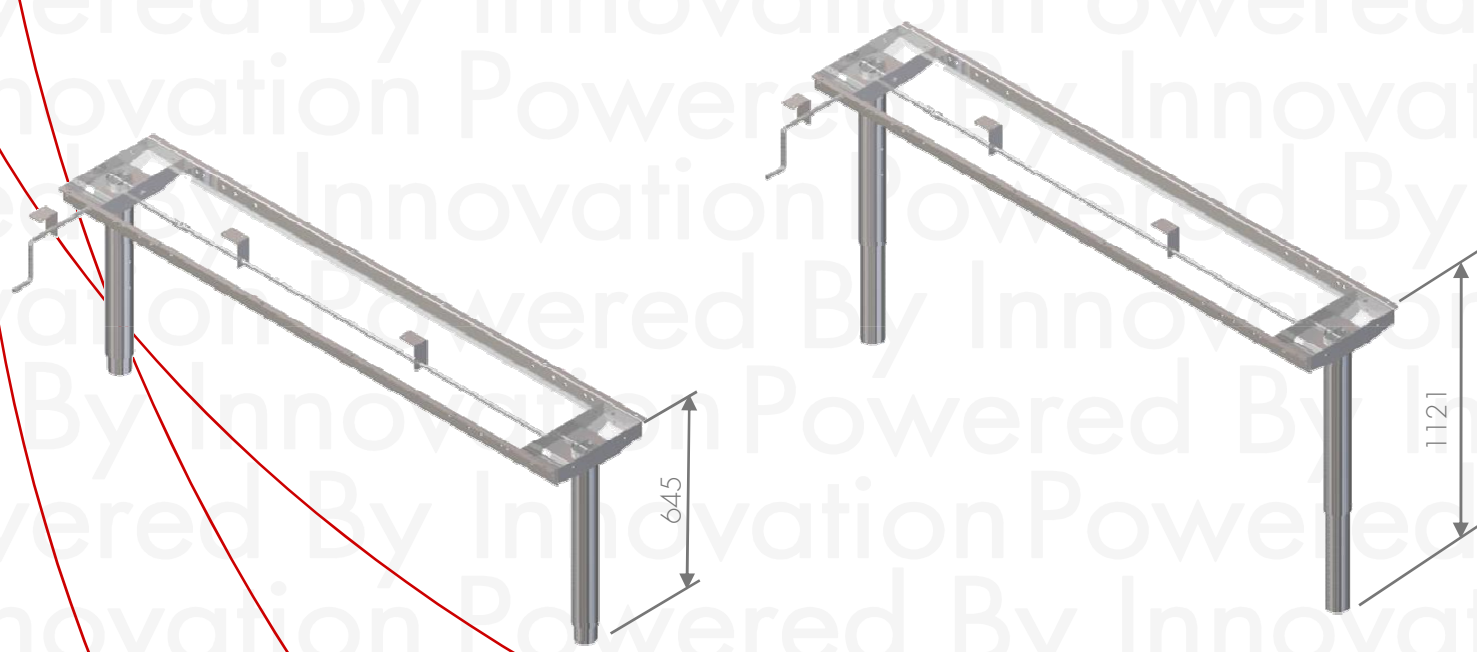
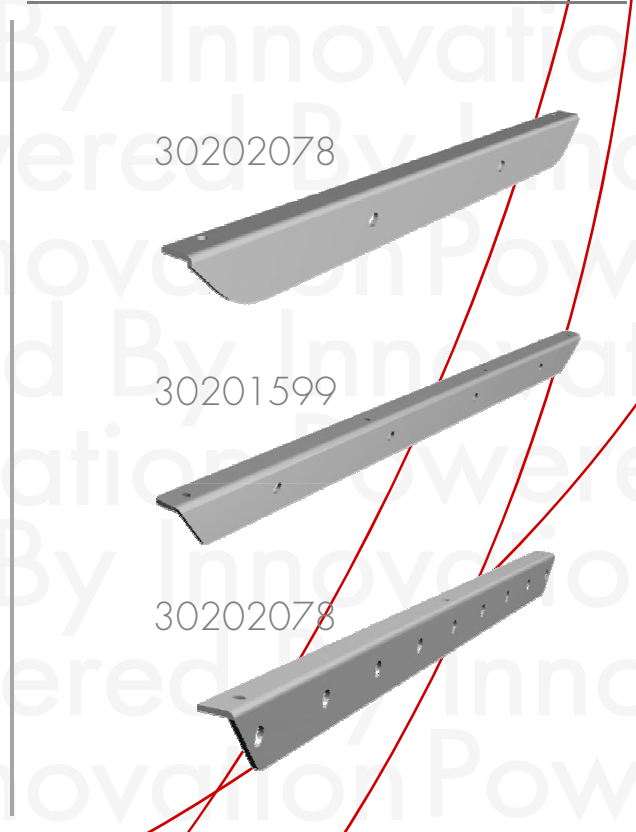

Powered By Innovation



# Stand ED Fixed Rect

30204981



Feet

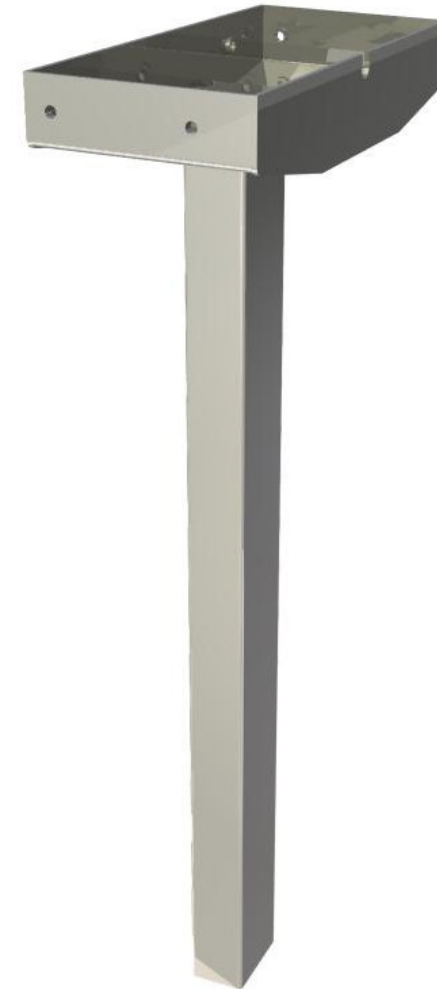

30205392

30202713

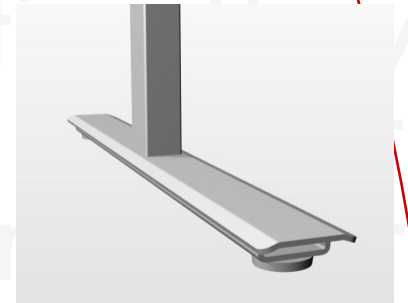
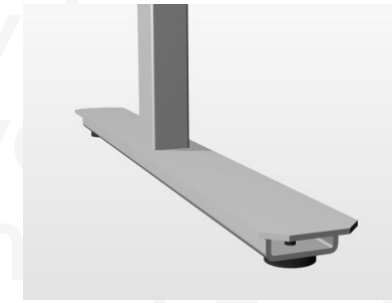

30204588

30203183

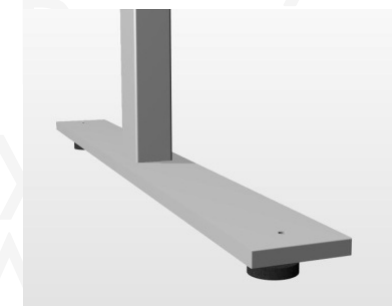

Frames

Sidebar



30205280

30204468

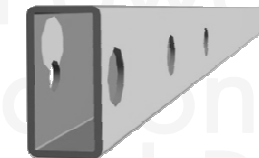

30205020

30204860

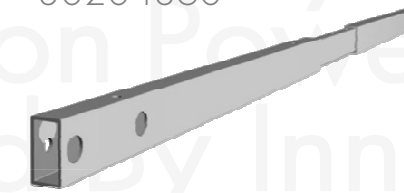

68000185

68000255\*

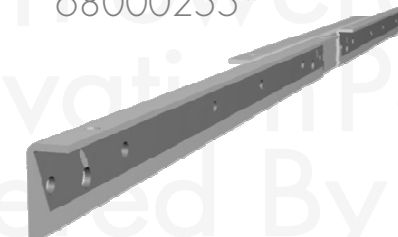
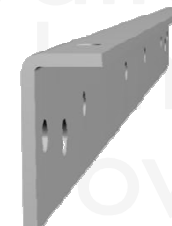

30202078

30201599

30202078

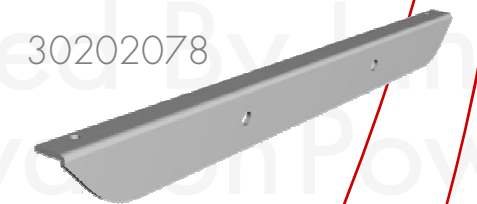

# Stand ED Screw 230 Round



30204744

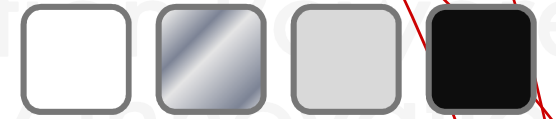

Frames

Sidebar

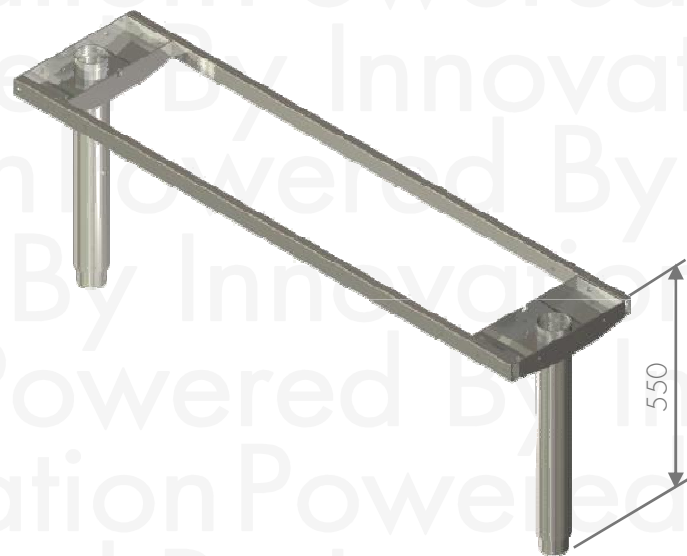
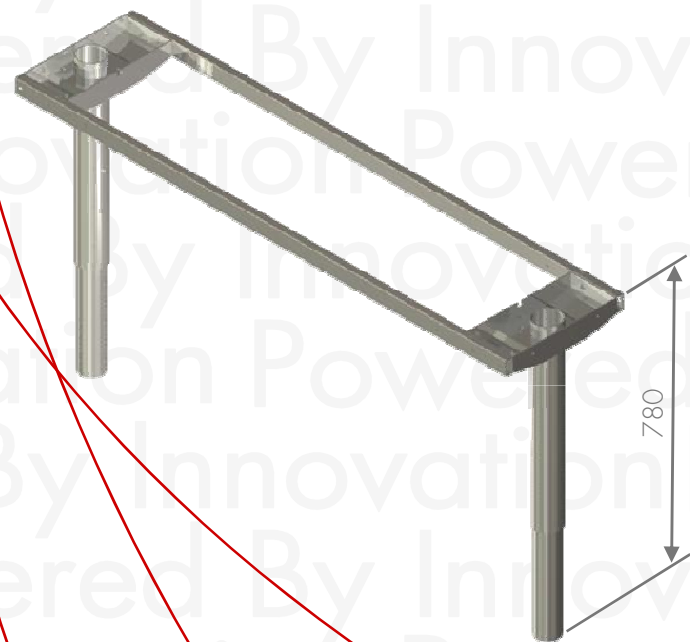

30205280



30205020



68000185

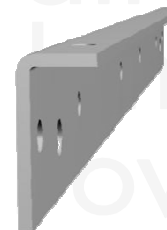

30204468

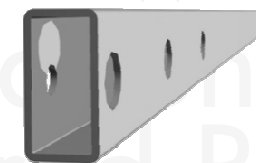

30204860

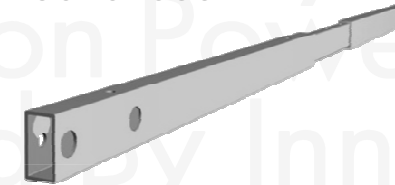

68000255\*



30202078

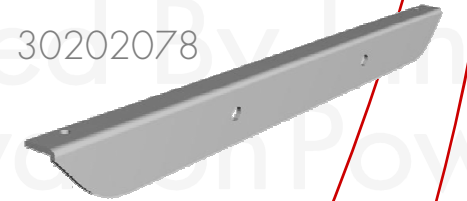

30201599



30202078

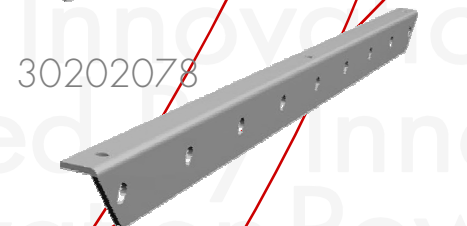

Powered By Innovation

[2009-11-12]

# Stand ED Screw 200 Rect

**ROL | ERGO**

30204571

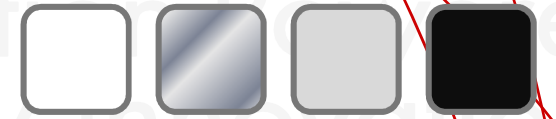

Feet

30205392

30202713

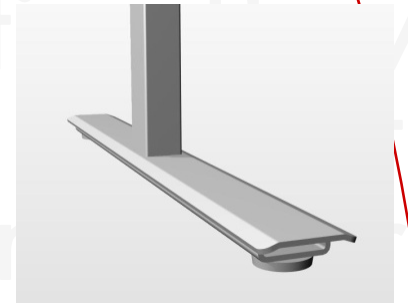
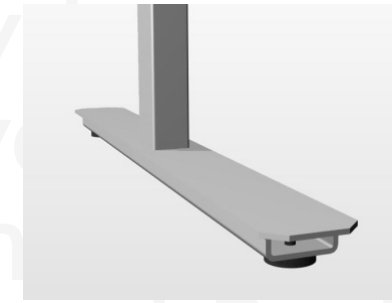

30204588

30203183

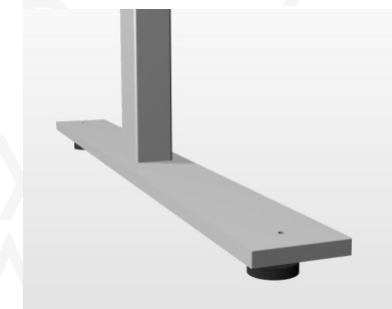

Frames

Sidebar

30205280

30204468

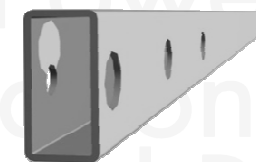

30205020

30204860

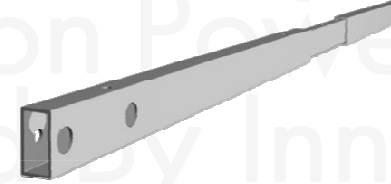

68000185

68000255\*

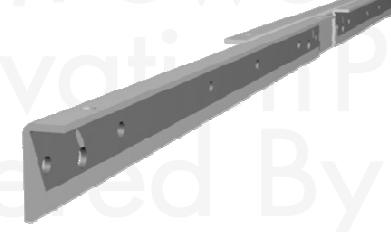
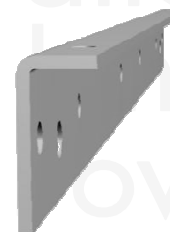

30202078

30201599

30202078

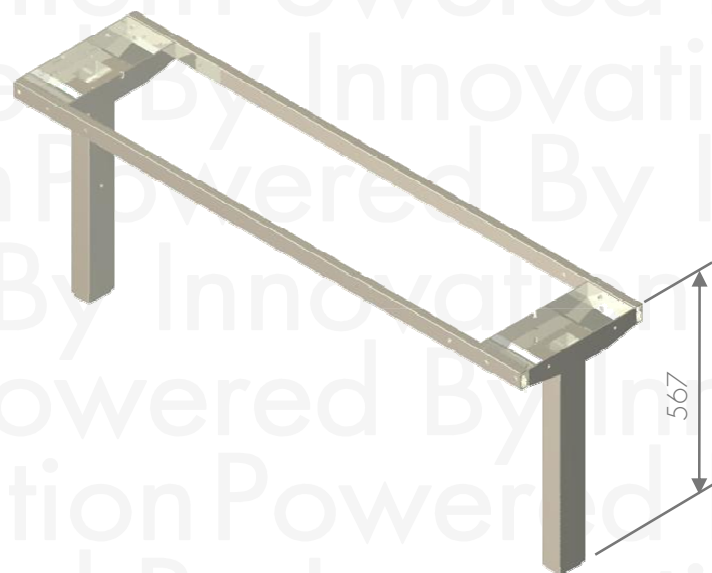
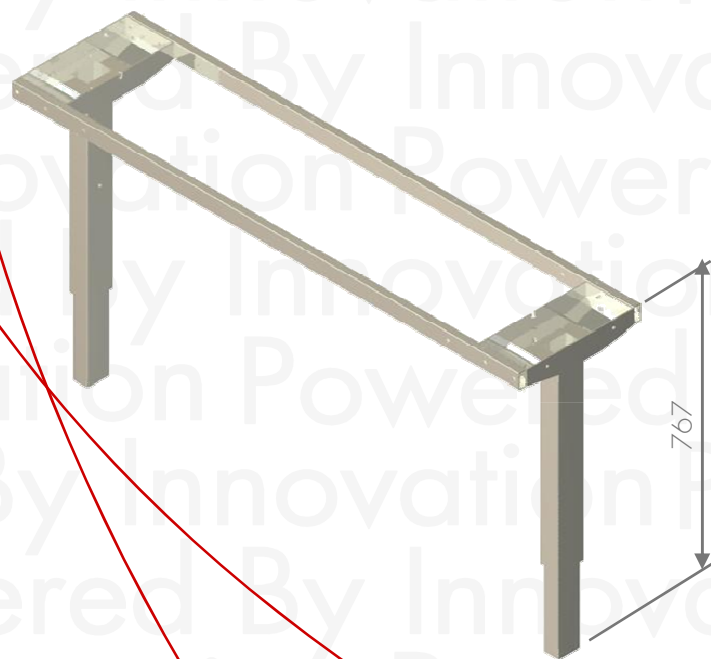
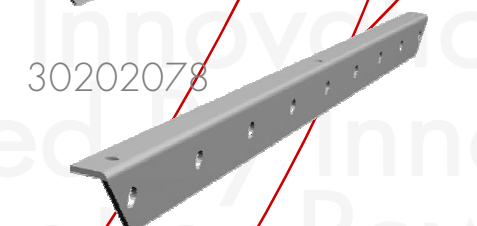
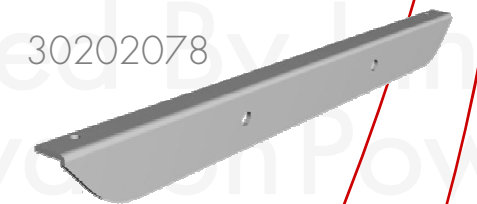

Powered By Innovation



# Stand DM Sync 600 Round

# ROL | ERGO

68000410 (68000419)

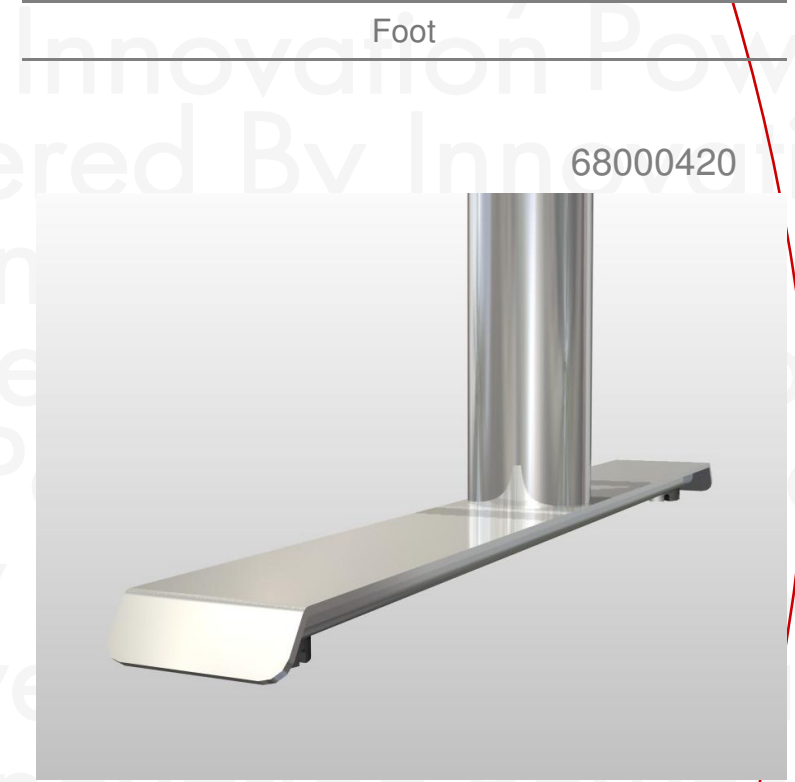
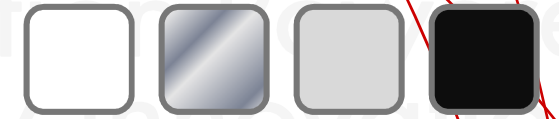

Foot

68000420

Frames

Sidebar

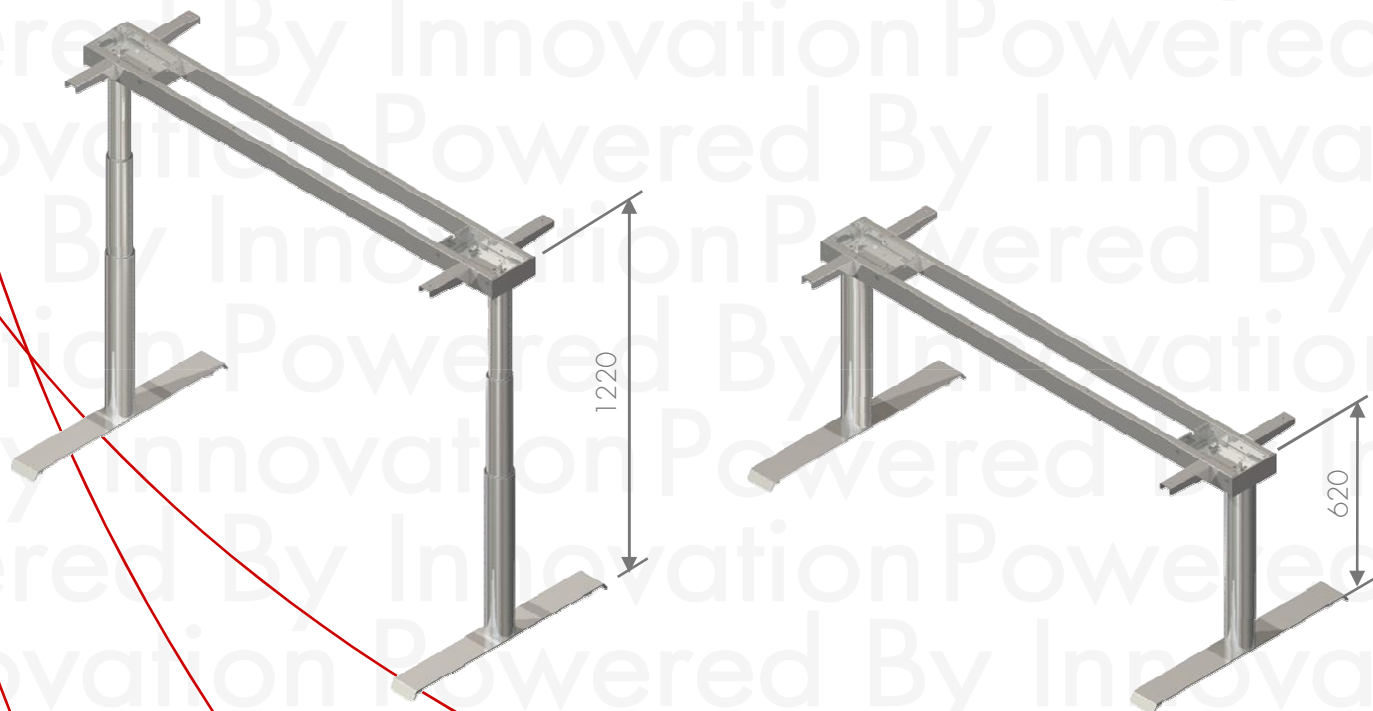

30204468 (40x20)

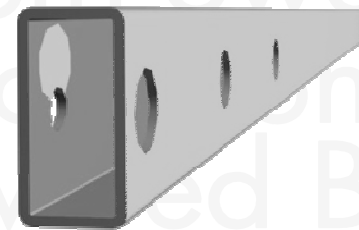

68000214 (60x20)



68000208



68000217

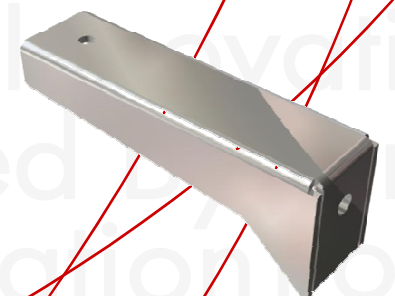

Powered By Innovation

[2009-11-12]

# Sidebar Adjustable Table Top

**ROL** | ERGO

30205529

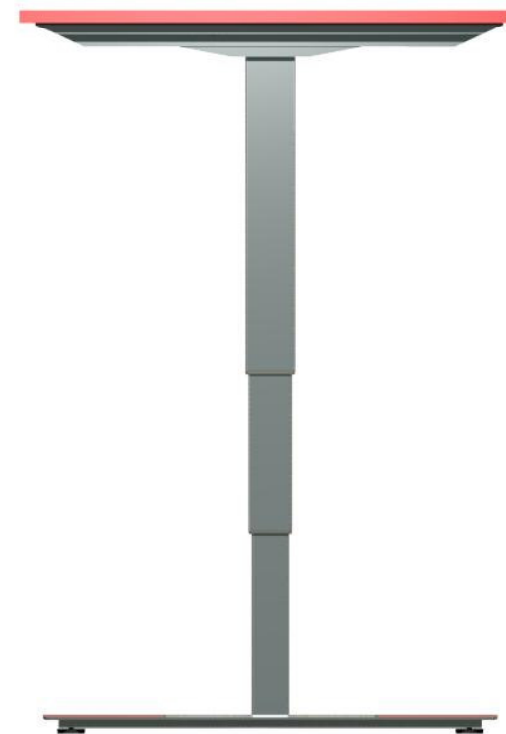
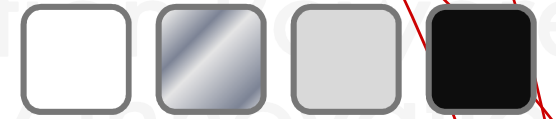

Powered By Innovation

# Bracket Boarder

**ROL** | ERGO

30205178

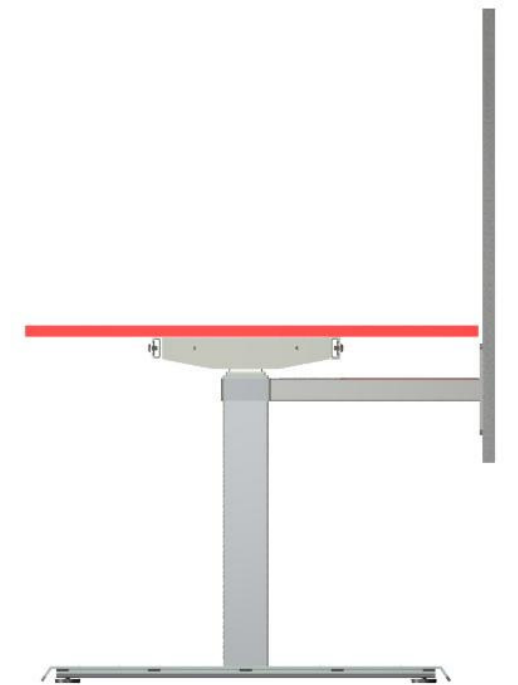
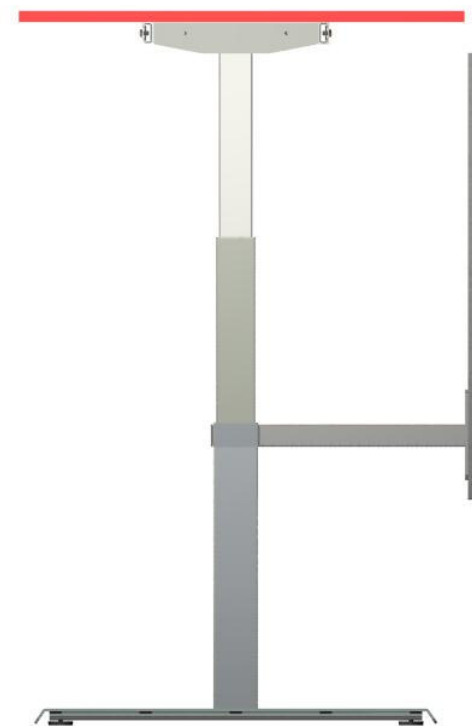
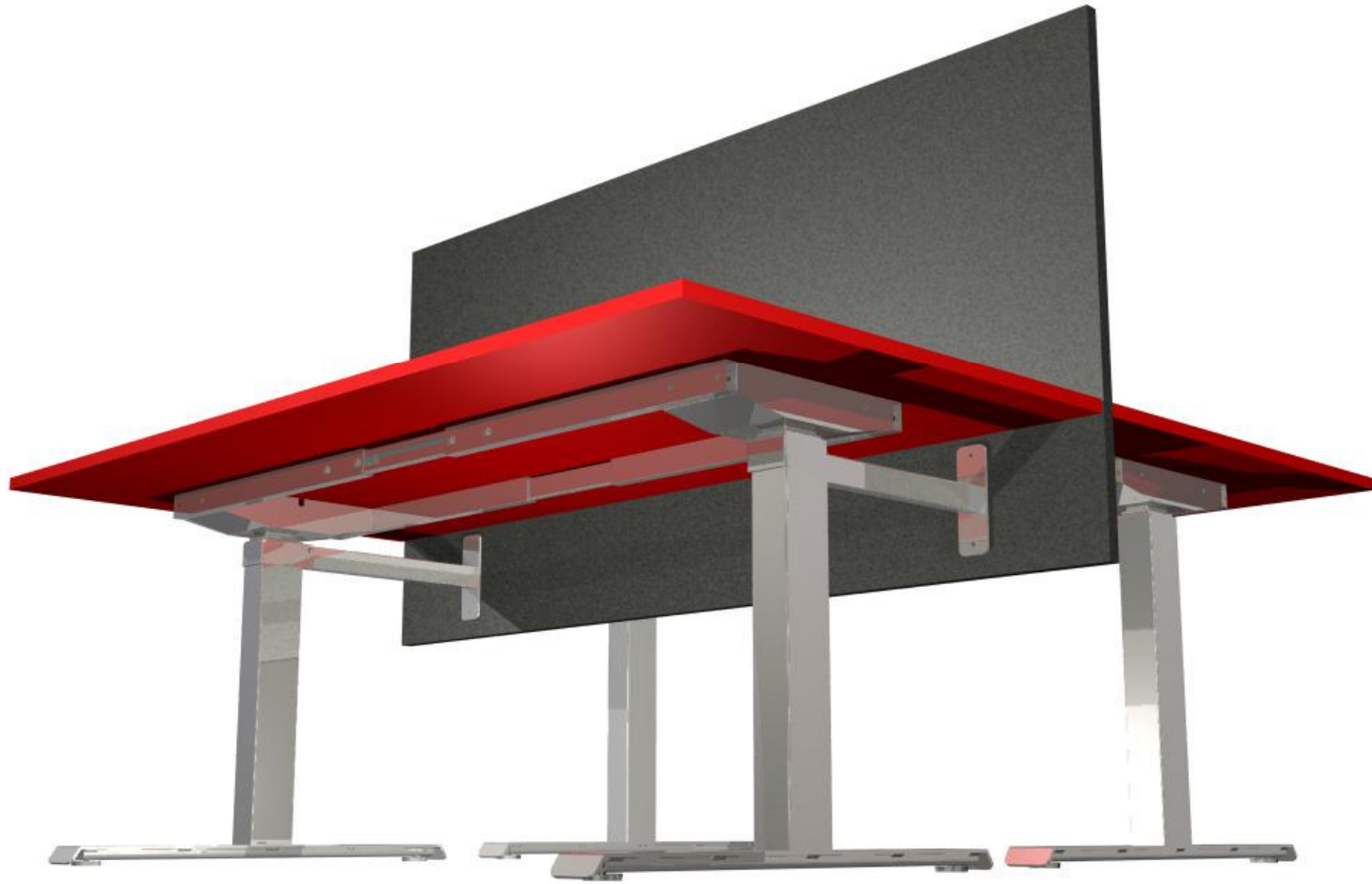
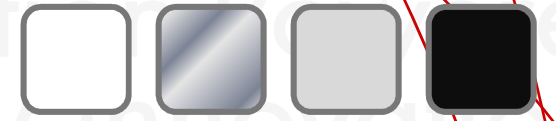

Powered By Innovation

[2009-11-12]



# Sidebar Adjustable Table Top Bracket Boarder

**ROL** | ERGO

30204551

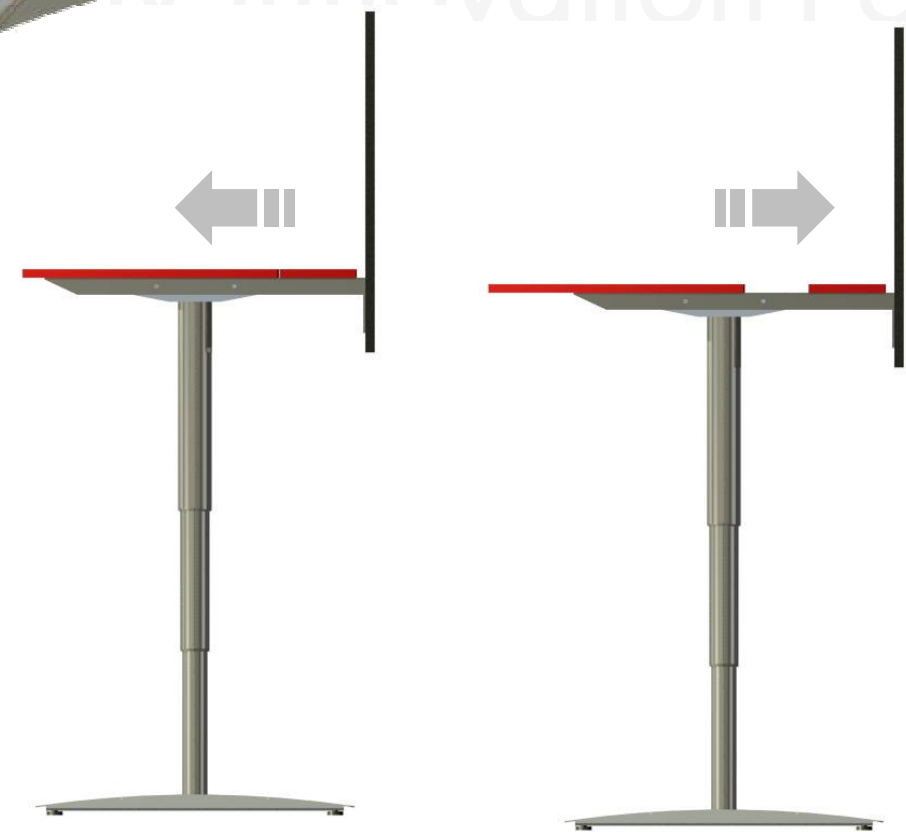
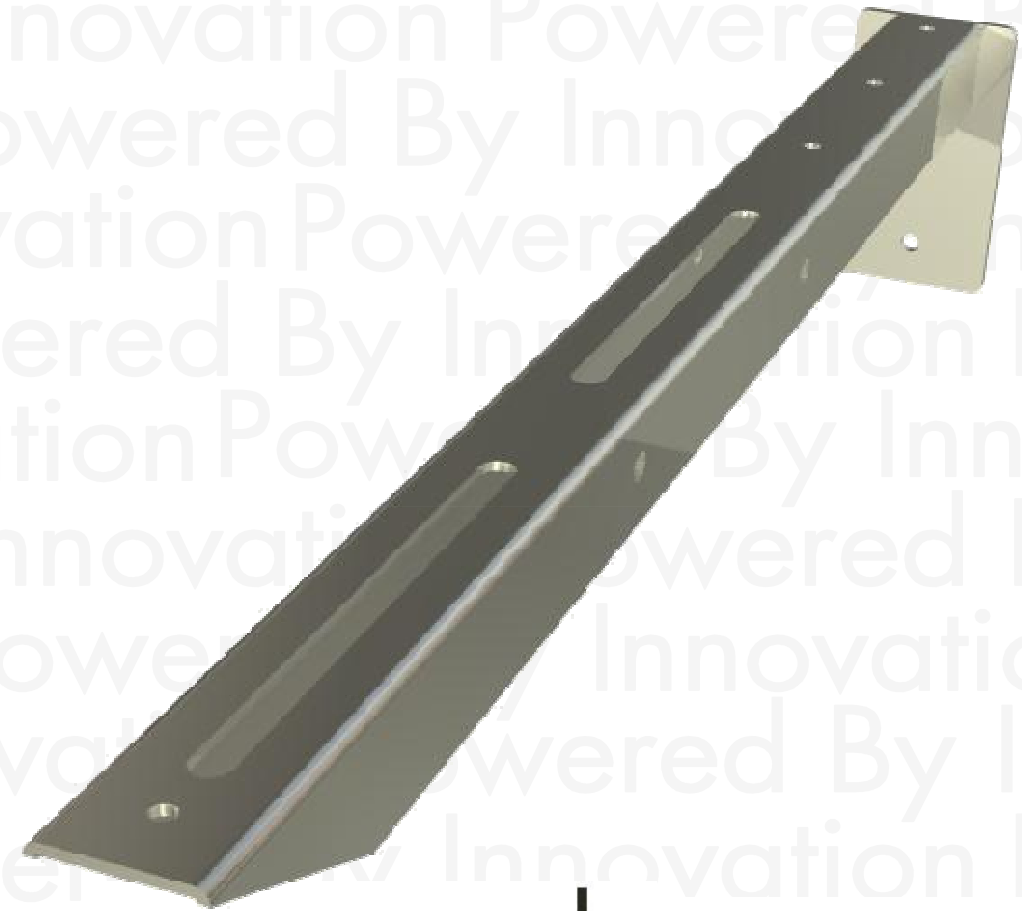
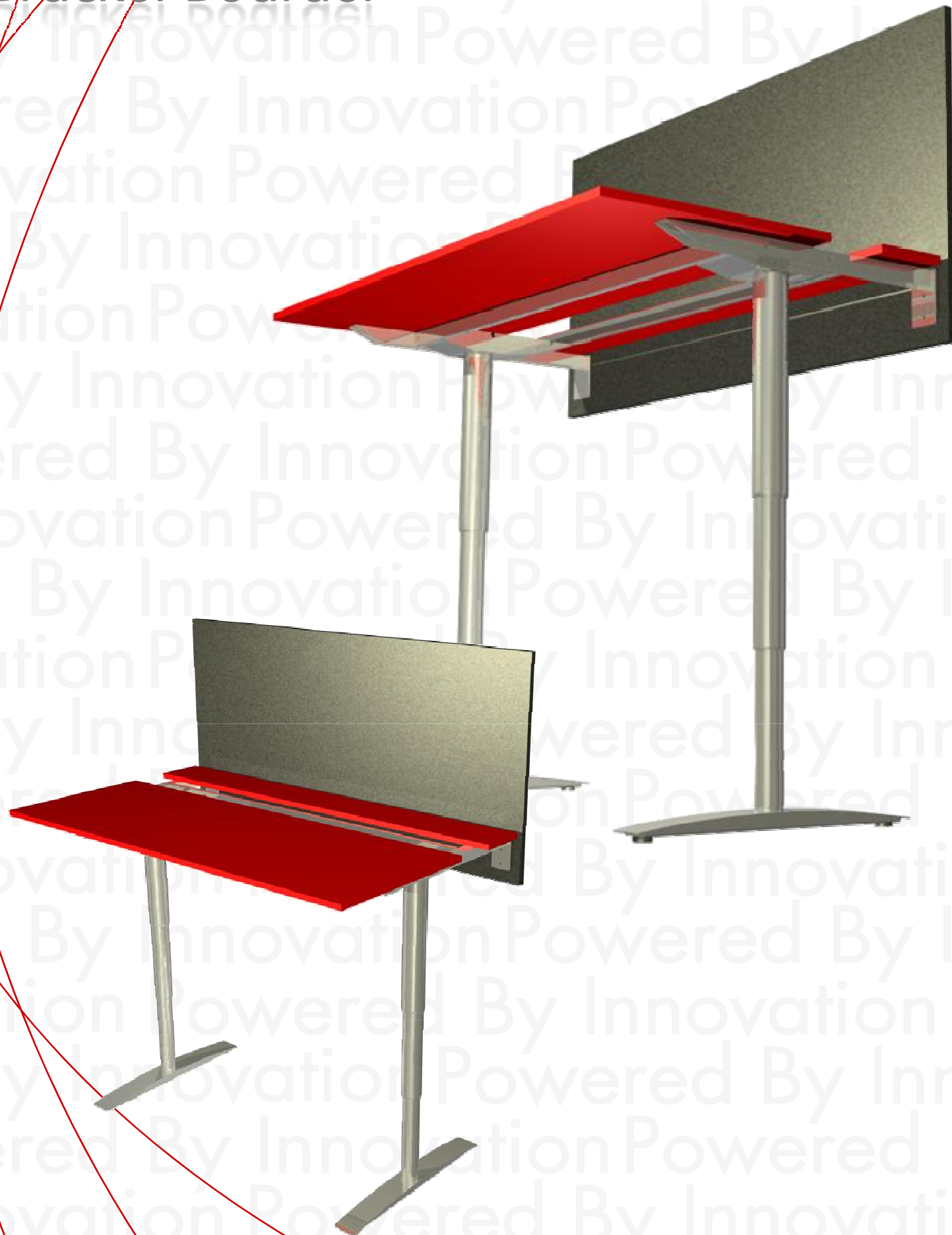
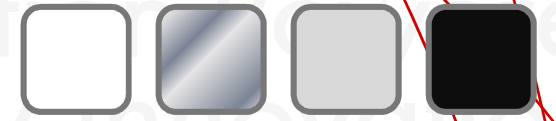

Powered By Innovation

[2009-11-12]

CPU

**ROL** | ERGO

30202937

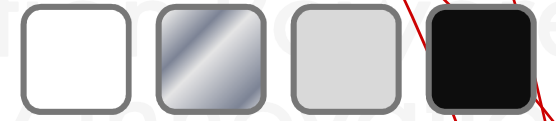

Powered By Innovation

[2009-11-12]

# Actuator ED 650

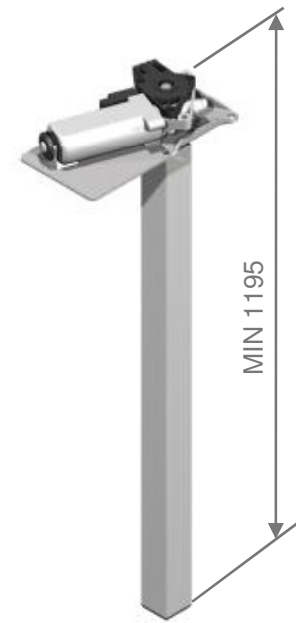
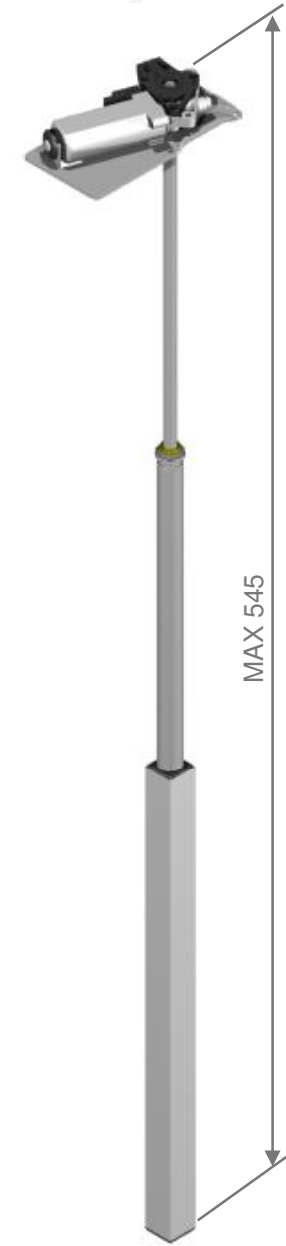
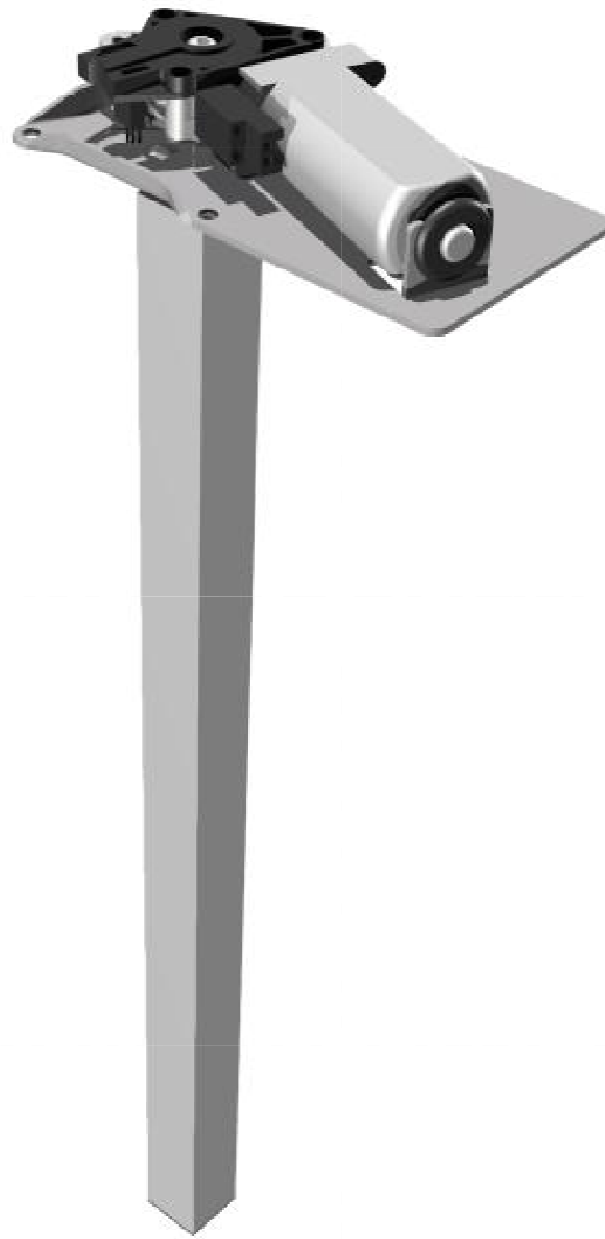



# Actuator ED 500

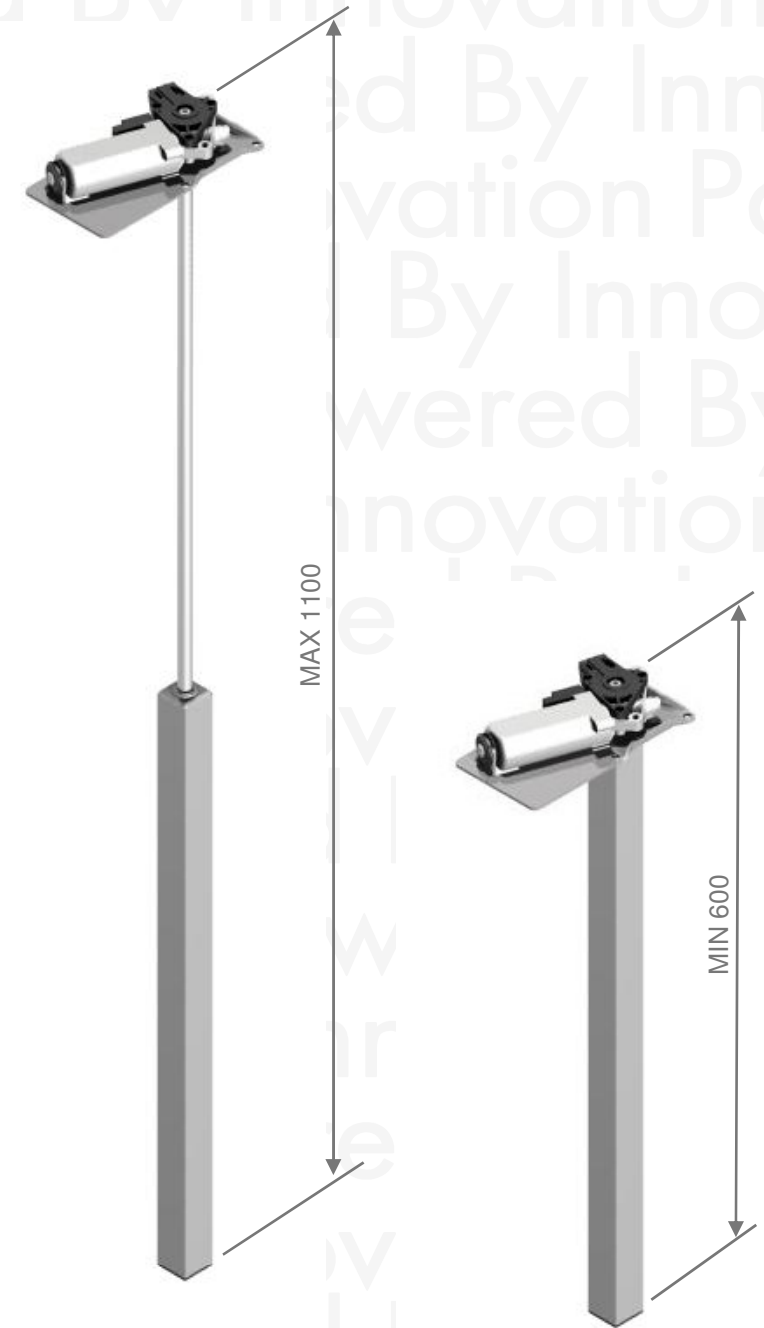
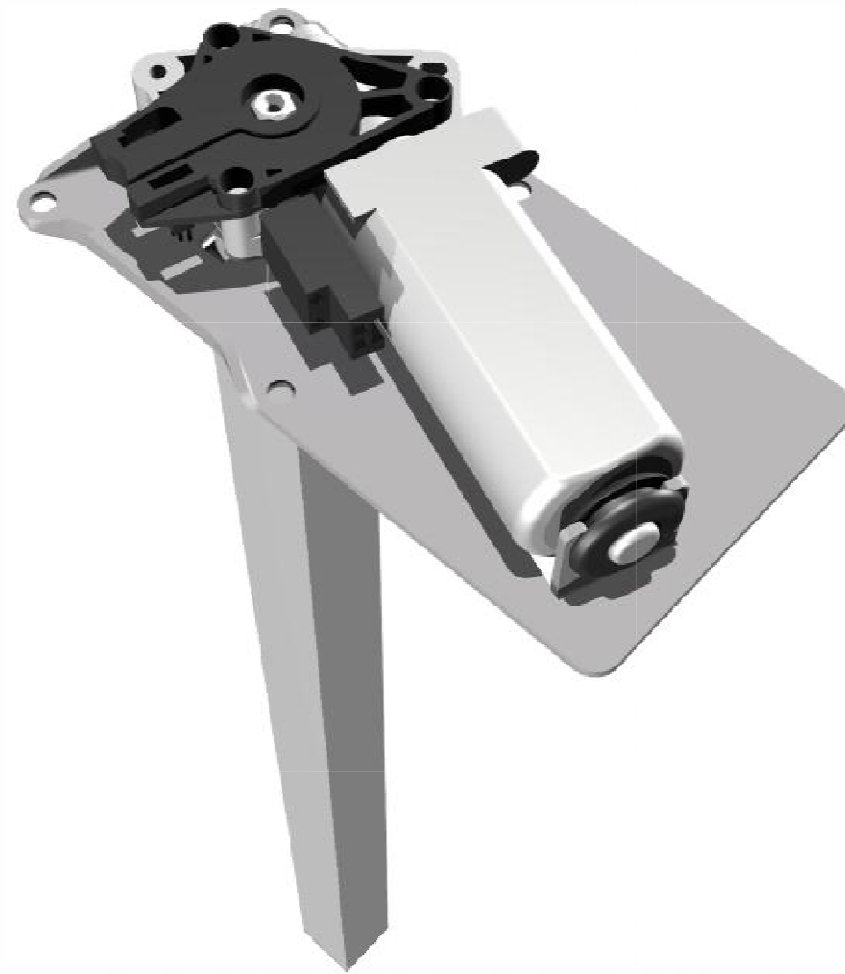
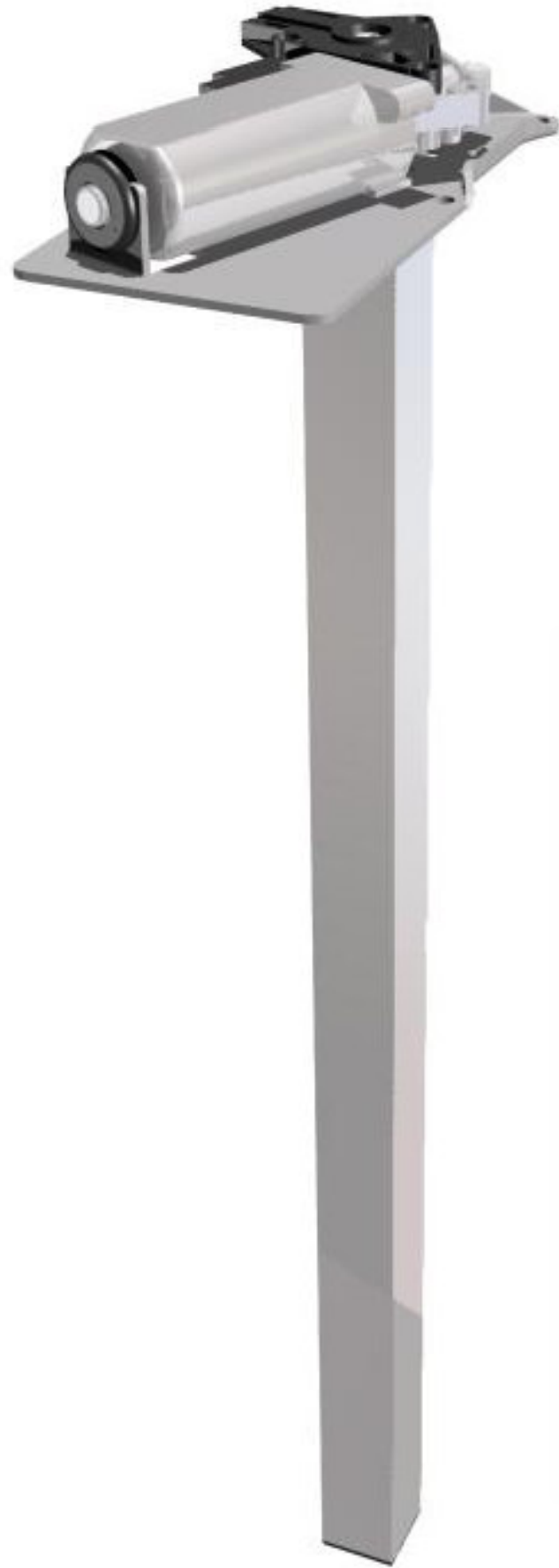

# Synchronize Spindle 650

**ROL** | ERGO

106752\_14ROL2\_3D

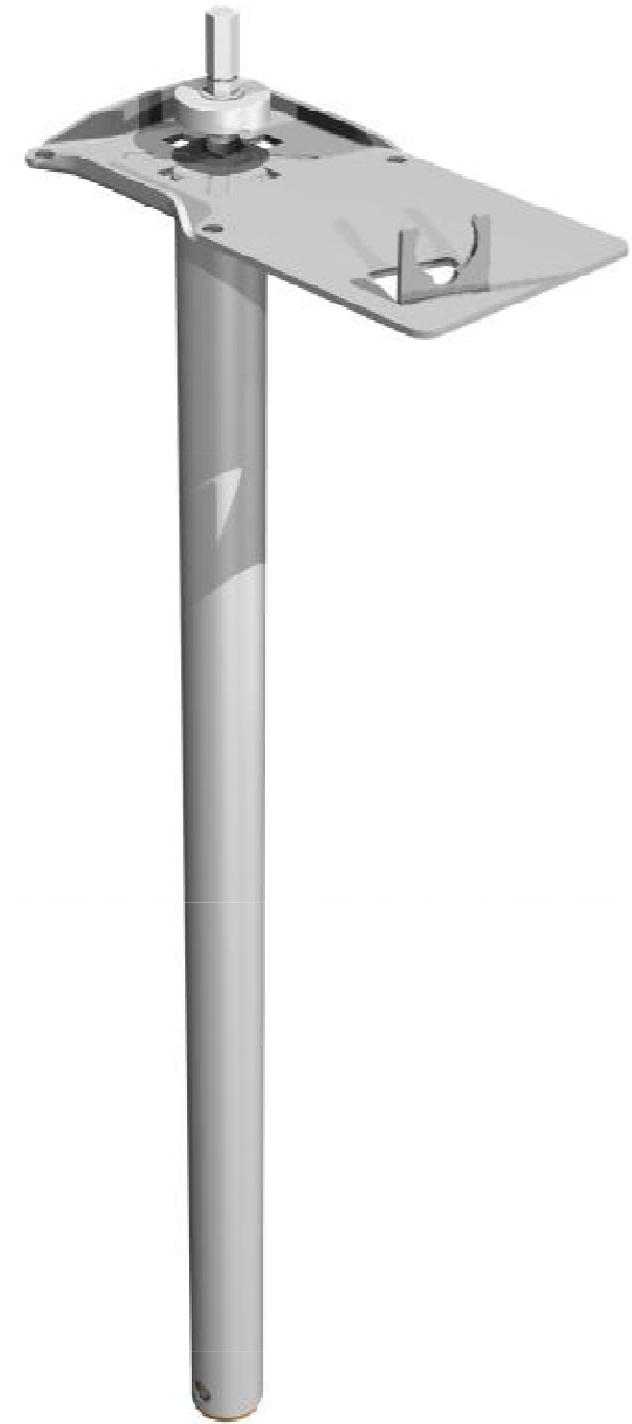
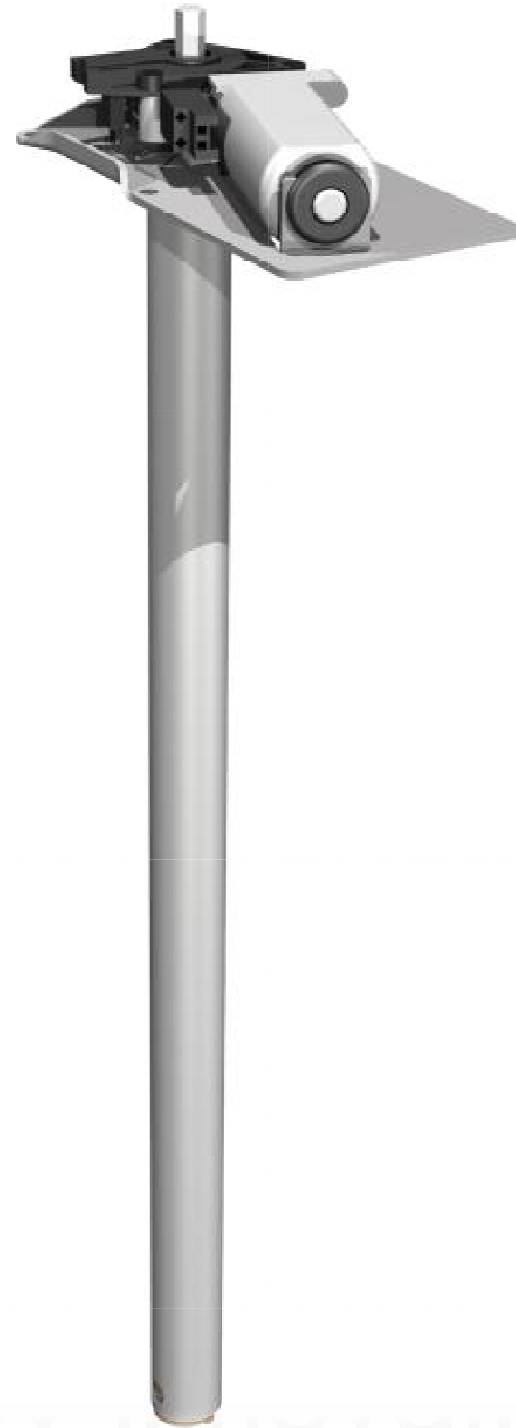
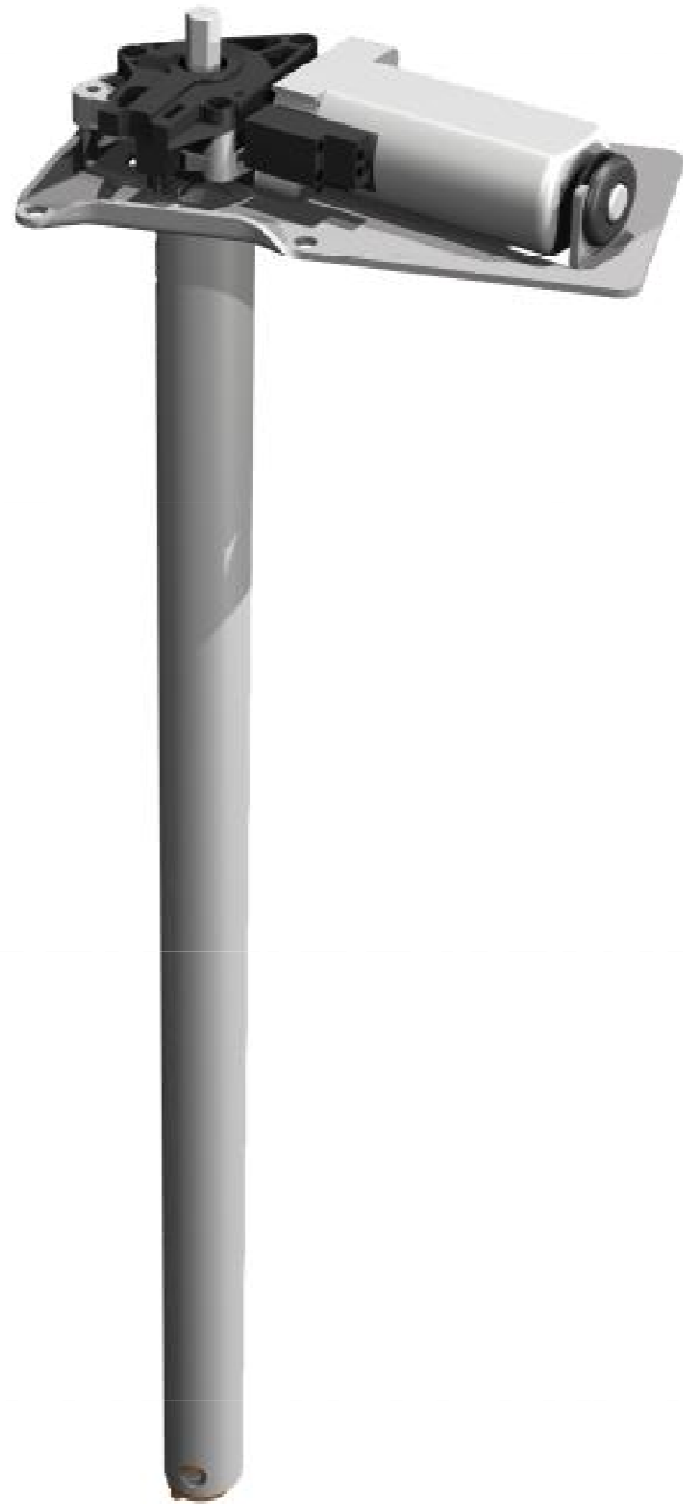

Powered By Innovation

[2009-11-12]

Control Box

**ROL** | ERGO

30204288

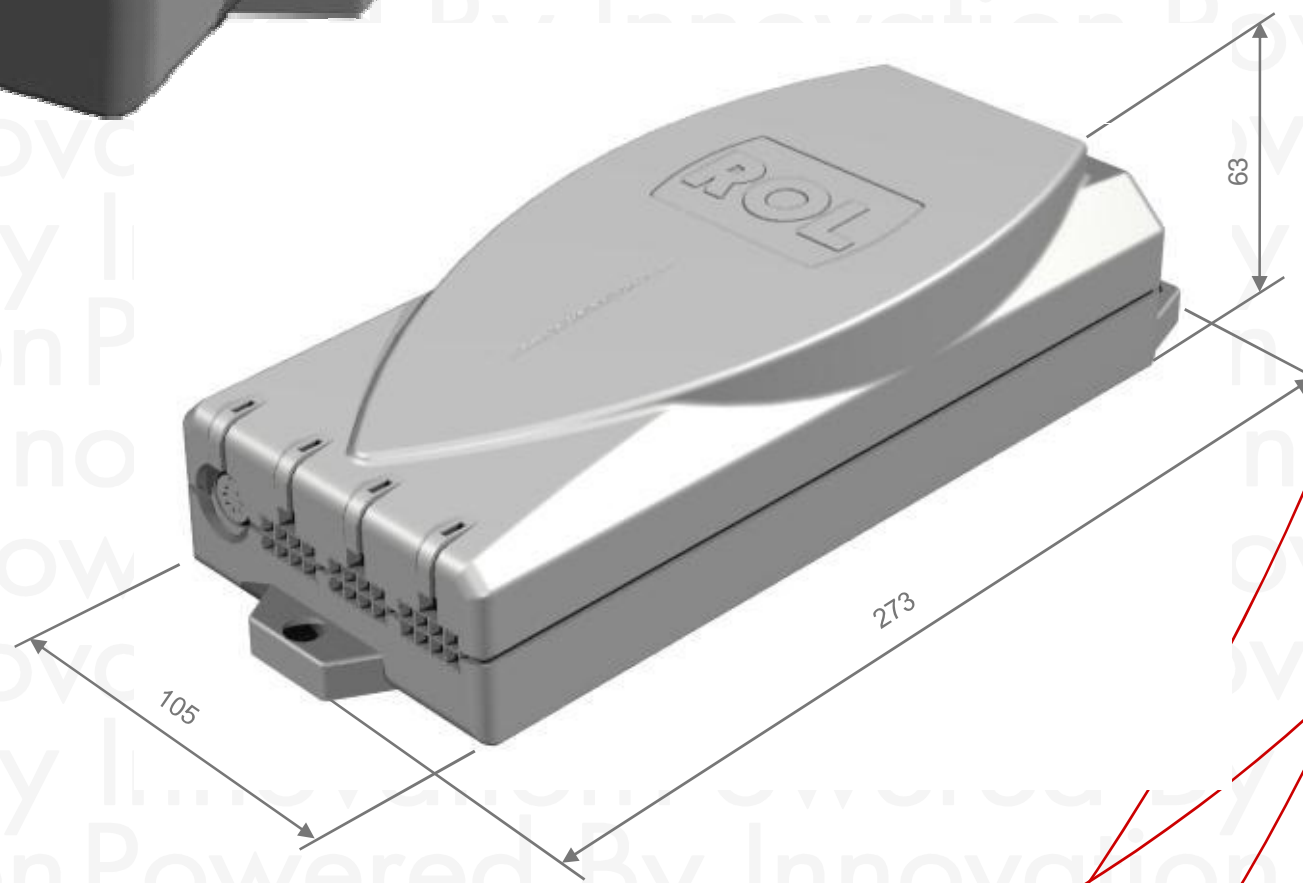

Powered By Innovation

[2009-11-12]

Engine

**ROL** | ERGO

30203020

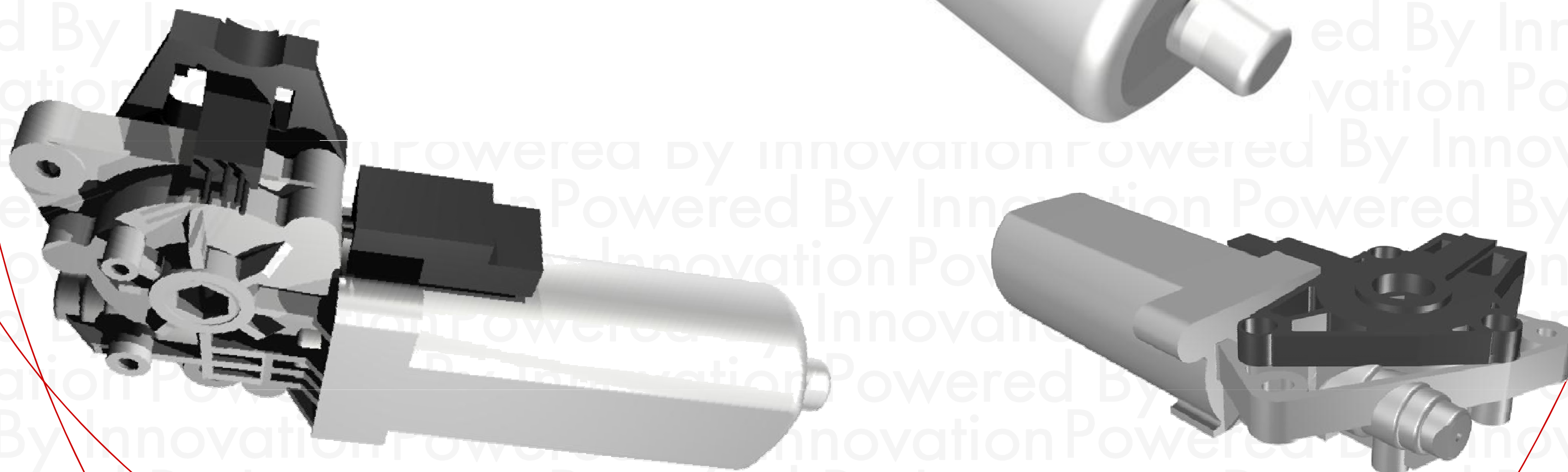
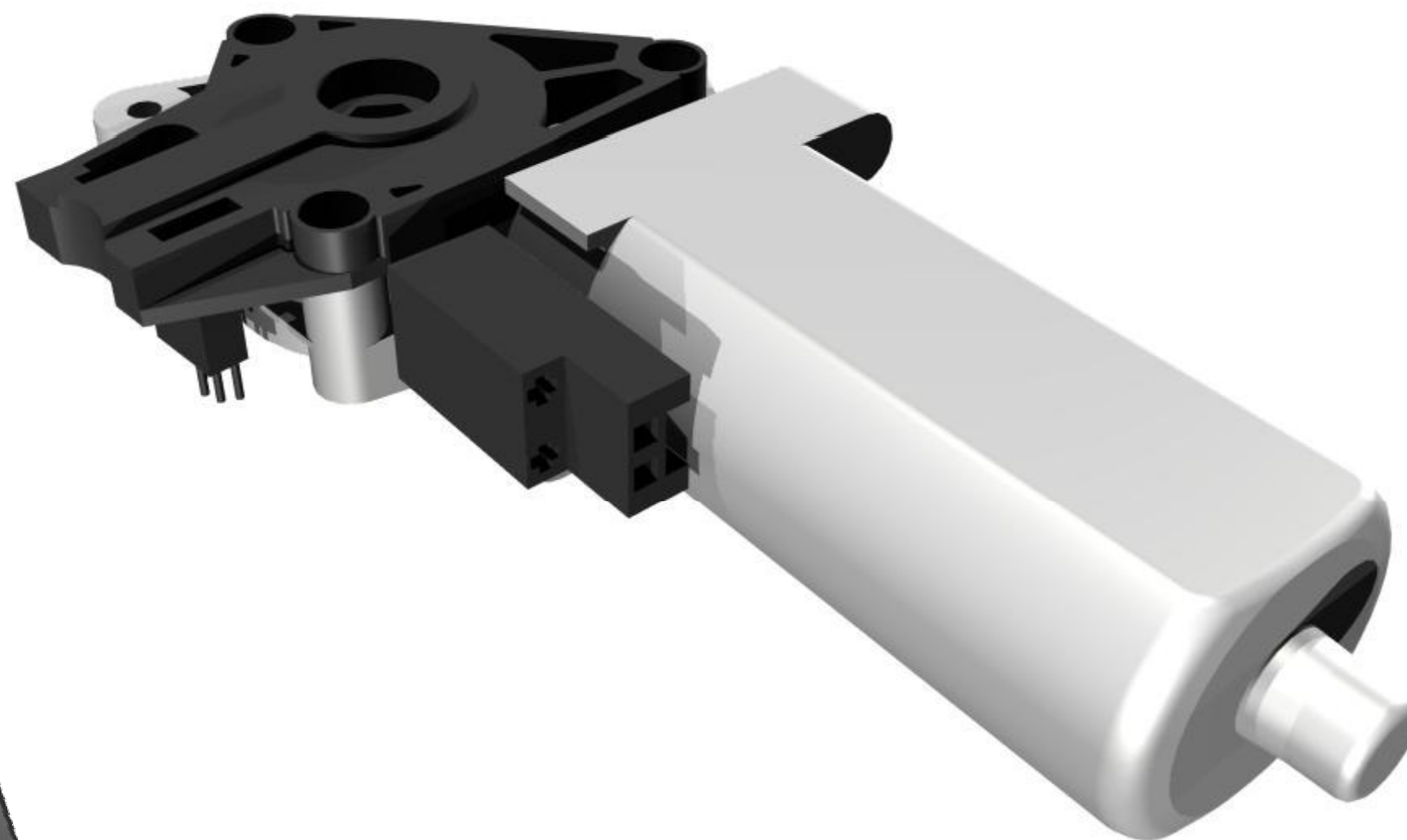

Powered By Innovation

[2009-11-12]



Display

**ROL** | ERGO

30204287



Powered By Innovation

[2009-11-12]

# Cable connection

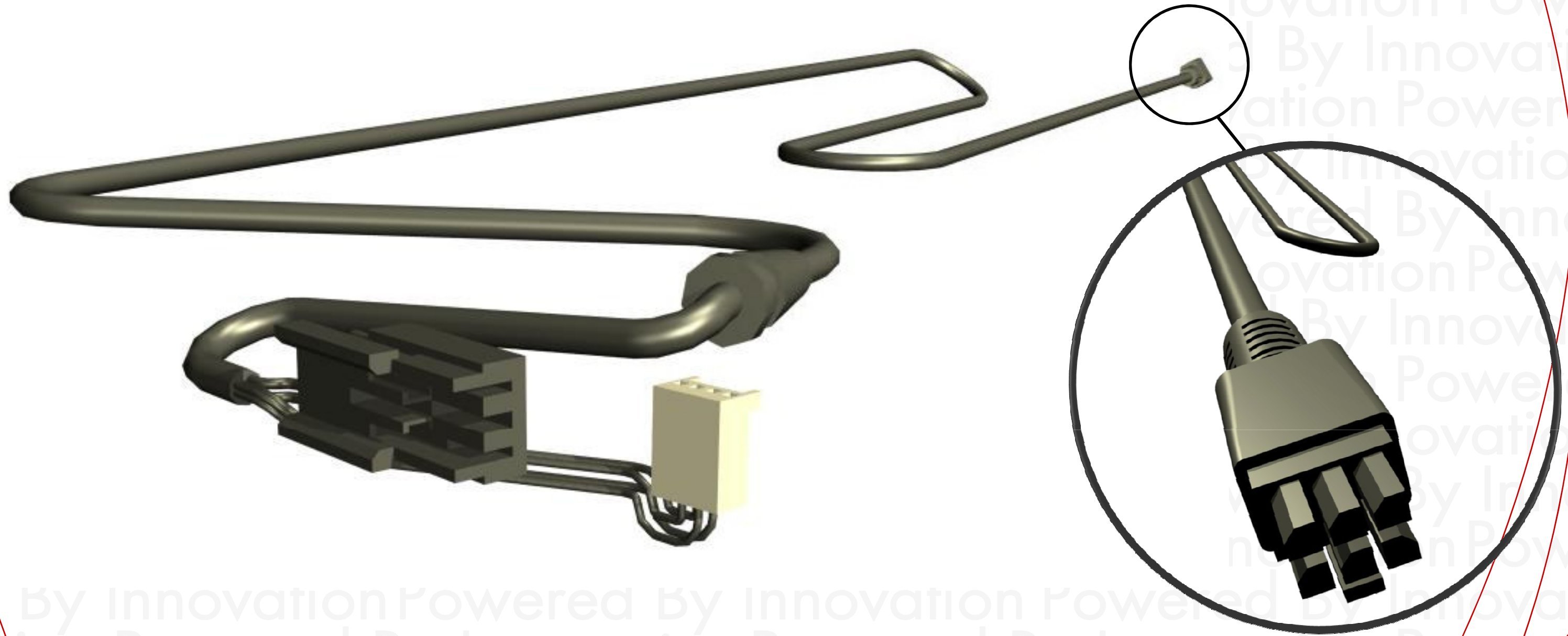



# Assembly Instructions

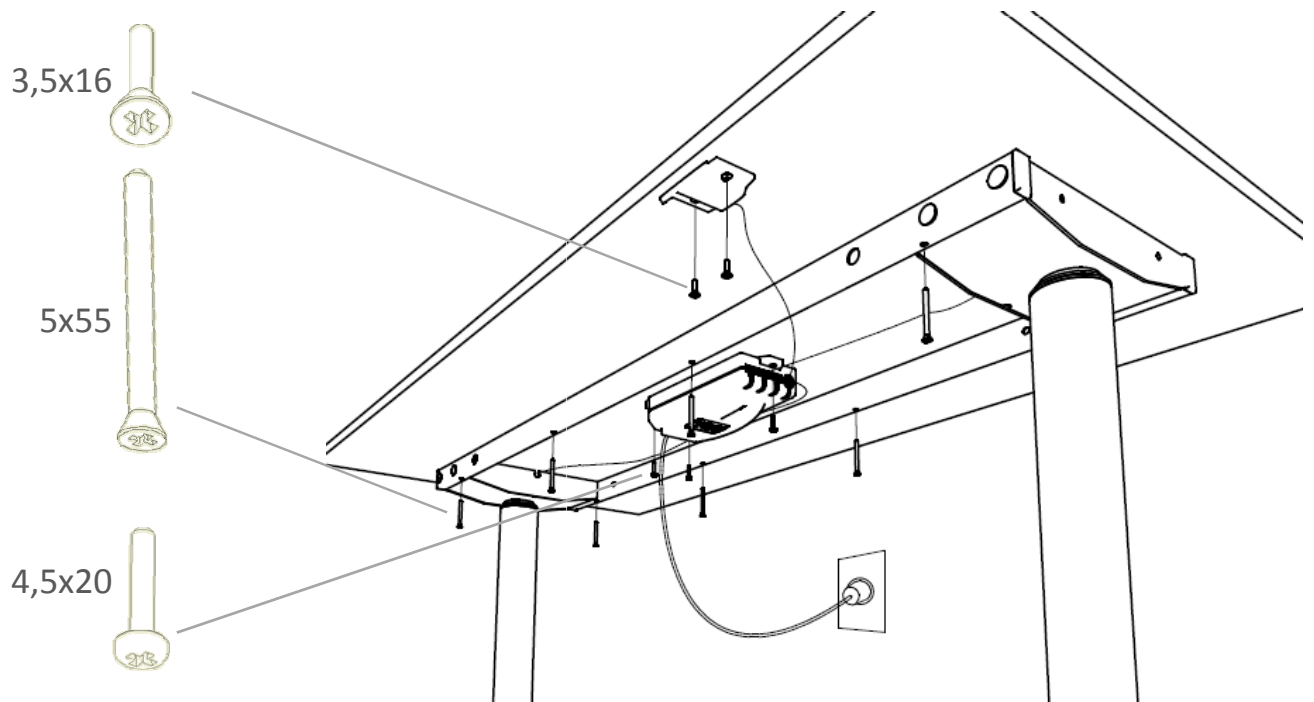
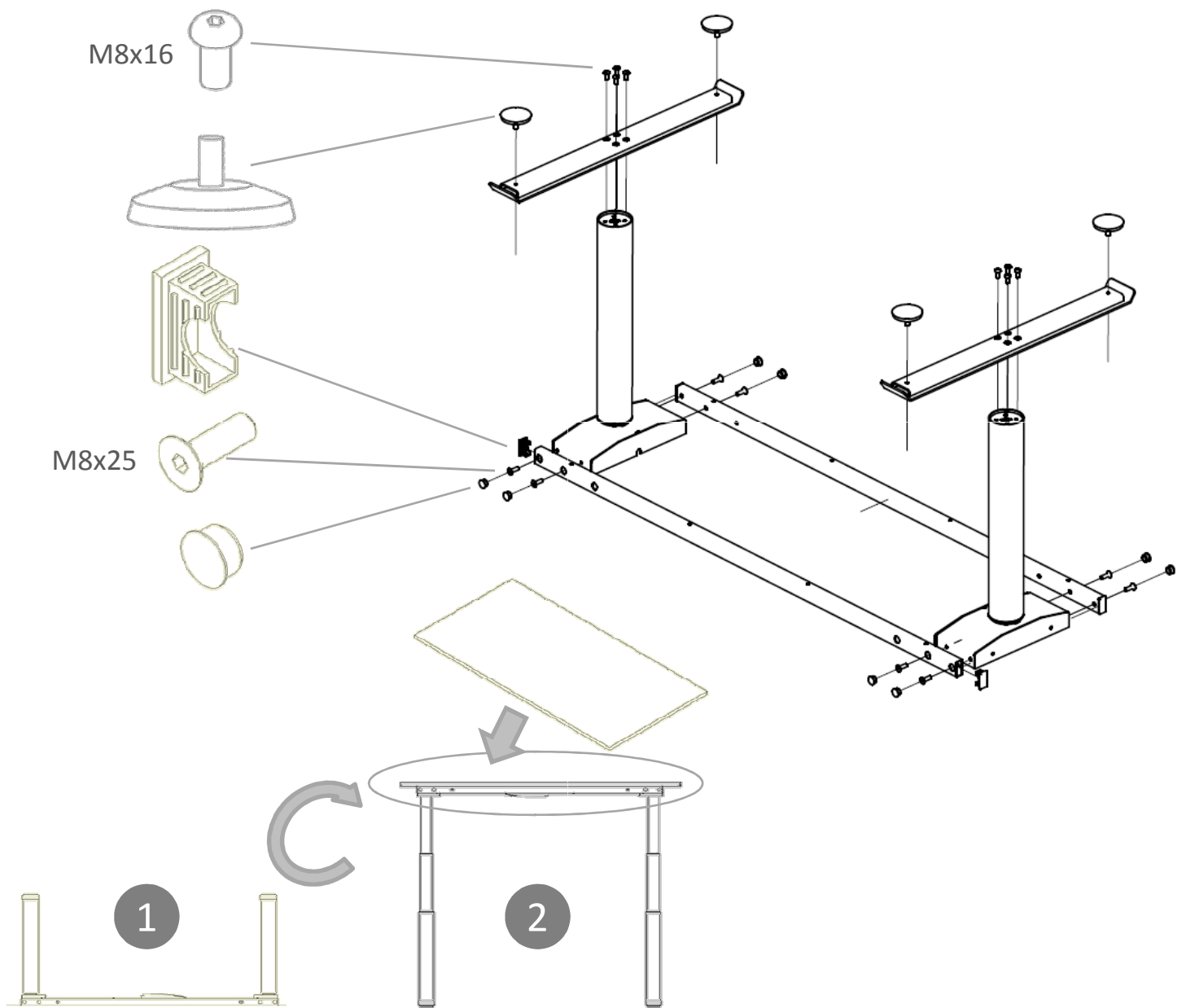

# Assembly Instructions

Stand ED 500 Rect  
Stand ED 650 Rect  
Stand ED USD 650 Rect  
Stand 470 Rect

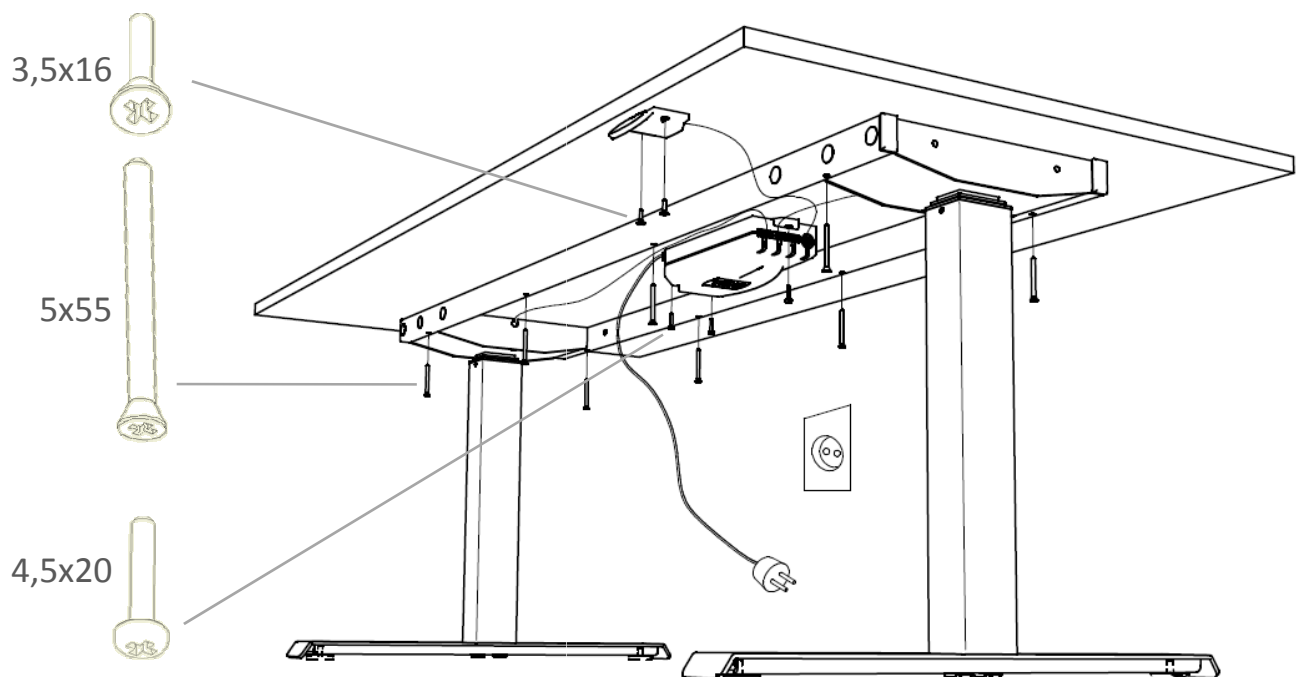
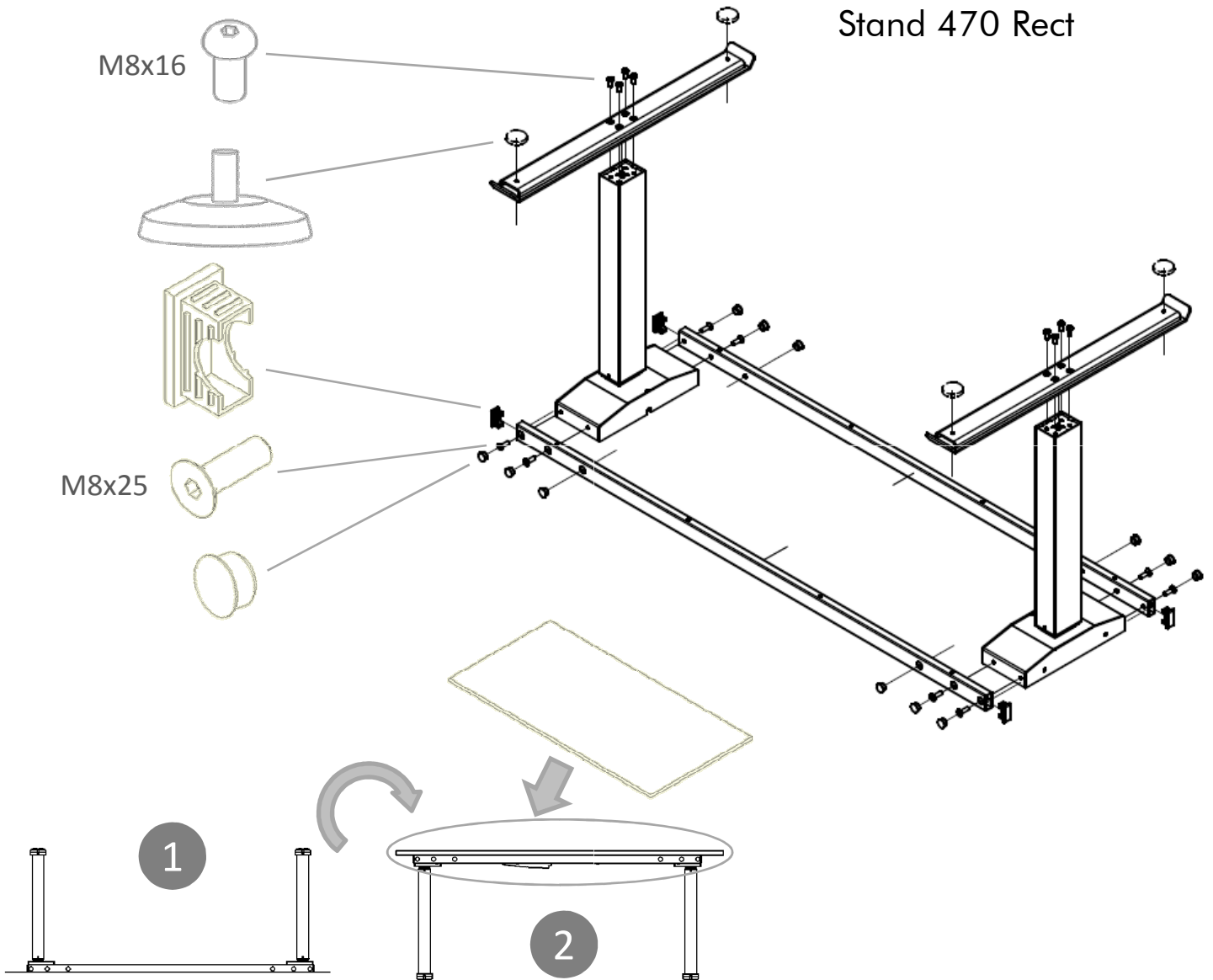

# Assembly Instructions

Stand ED 500 Rect  
Stand ED 650 Rect  
Stand ED USD 650 Rect  
Stand 470 Rect

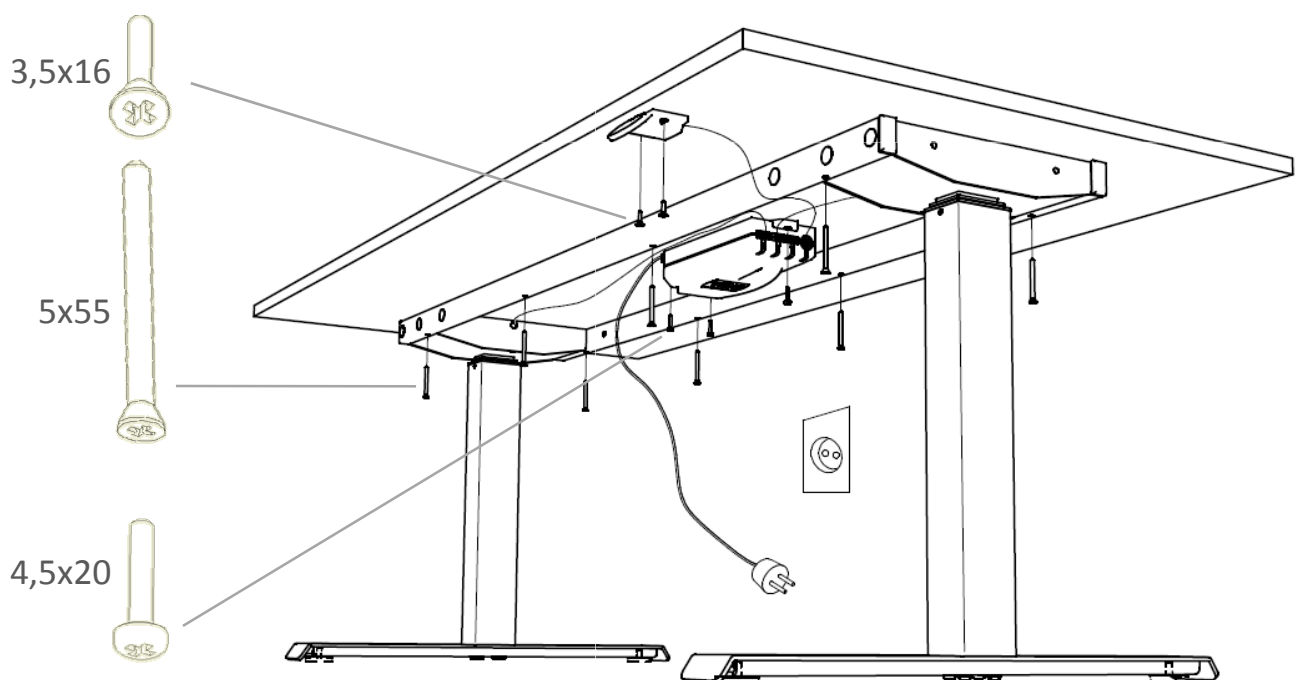
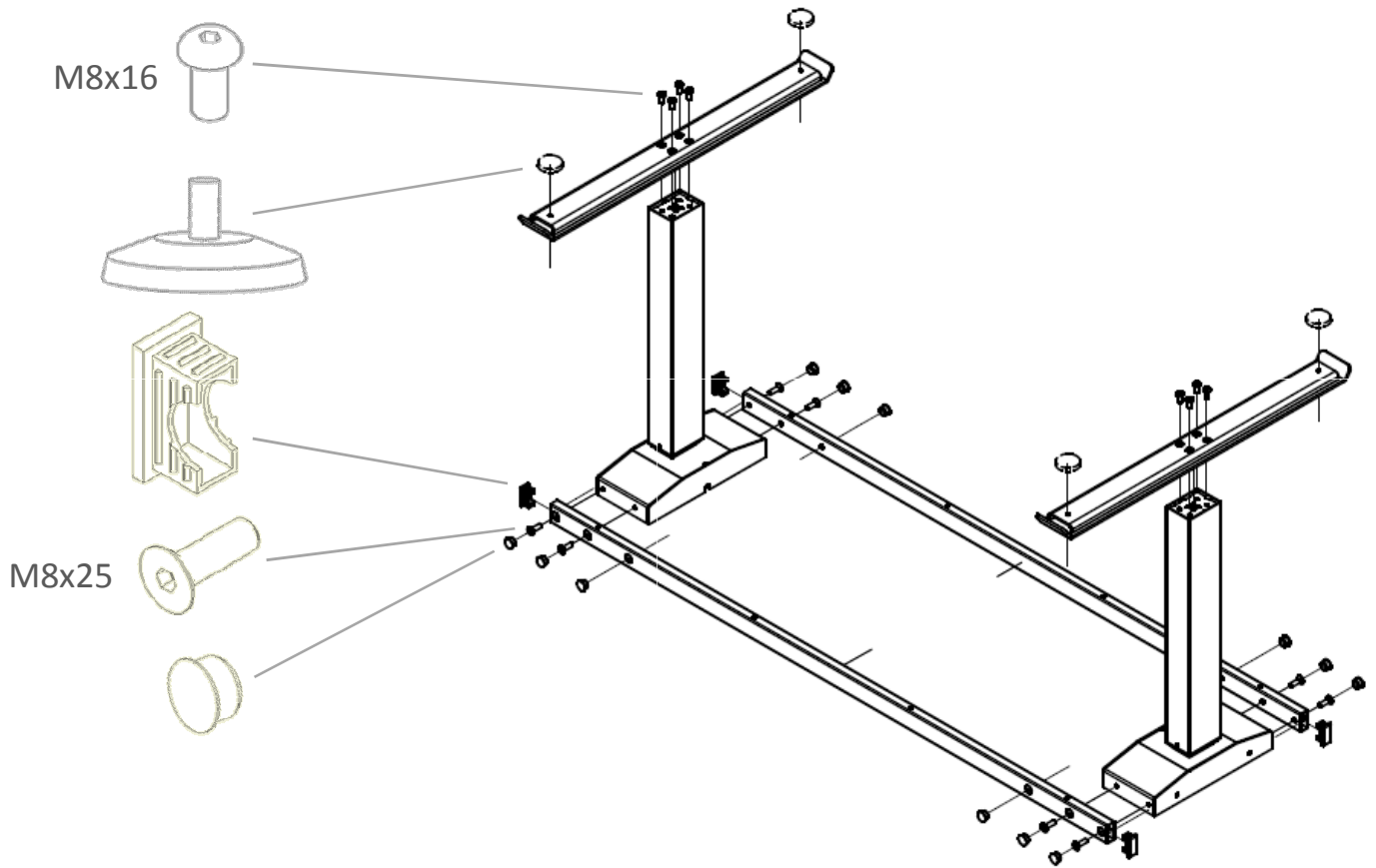

# Assembly Instructions

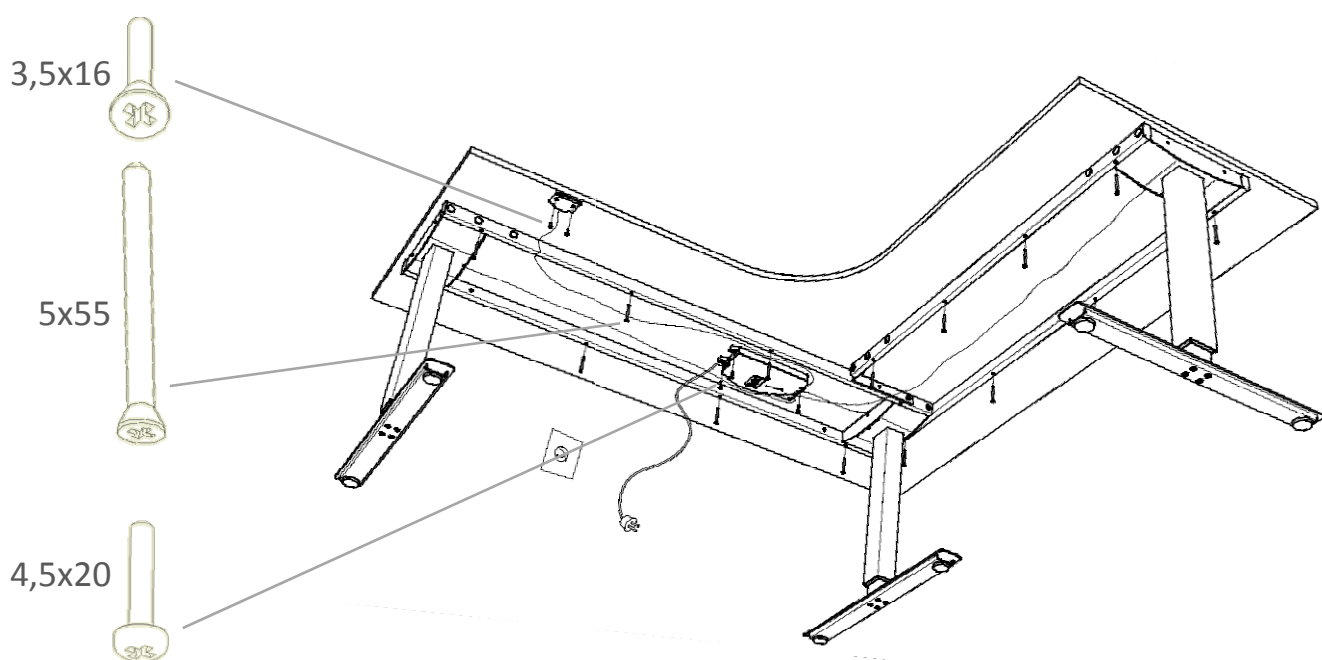
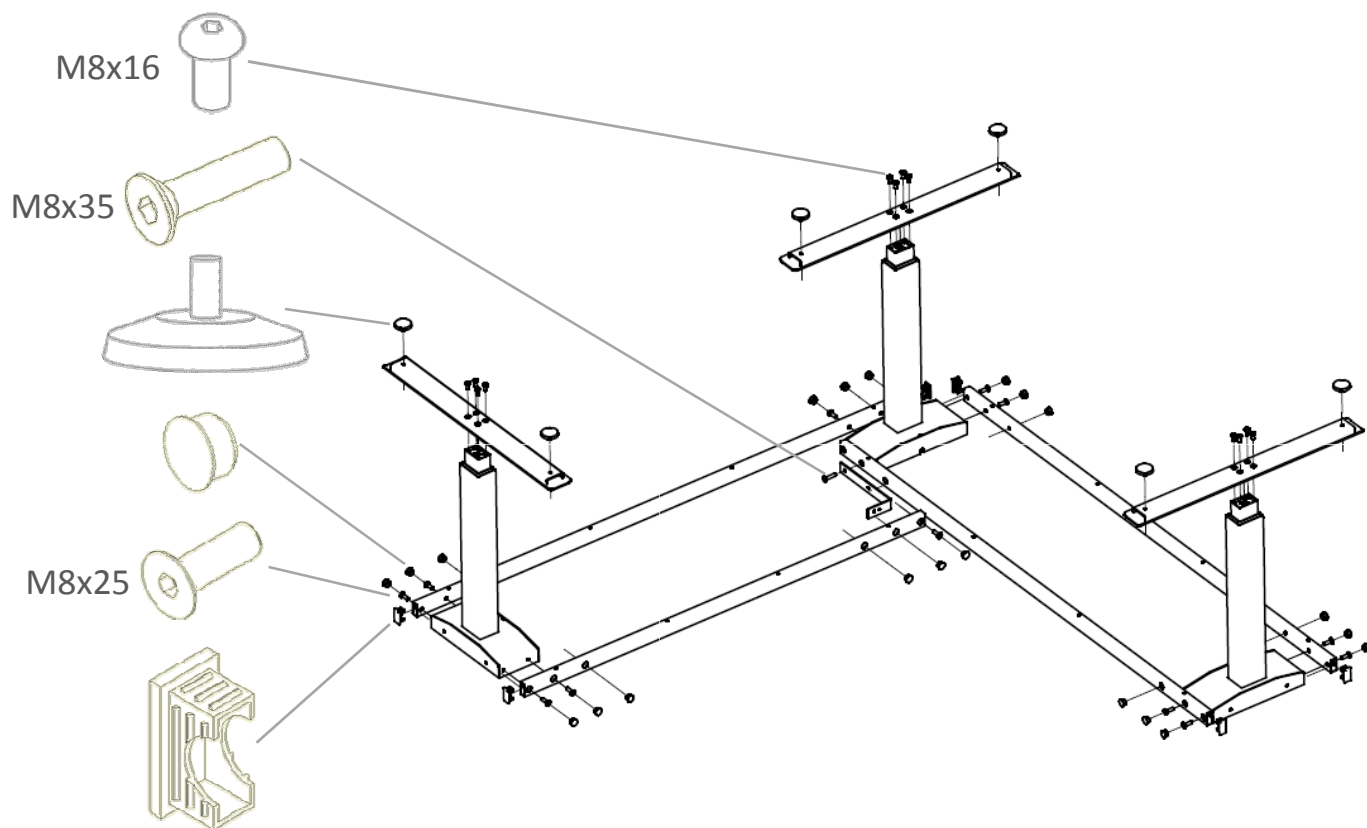

# Assembly Instructions

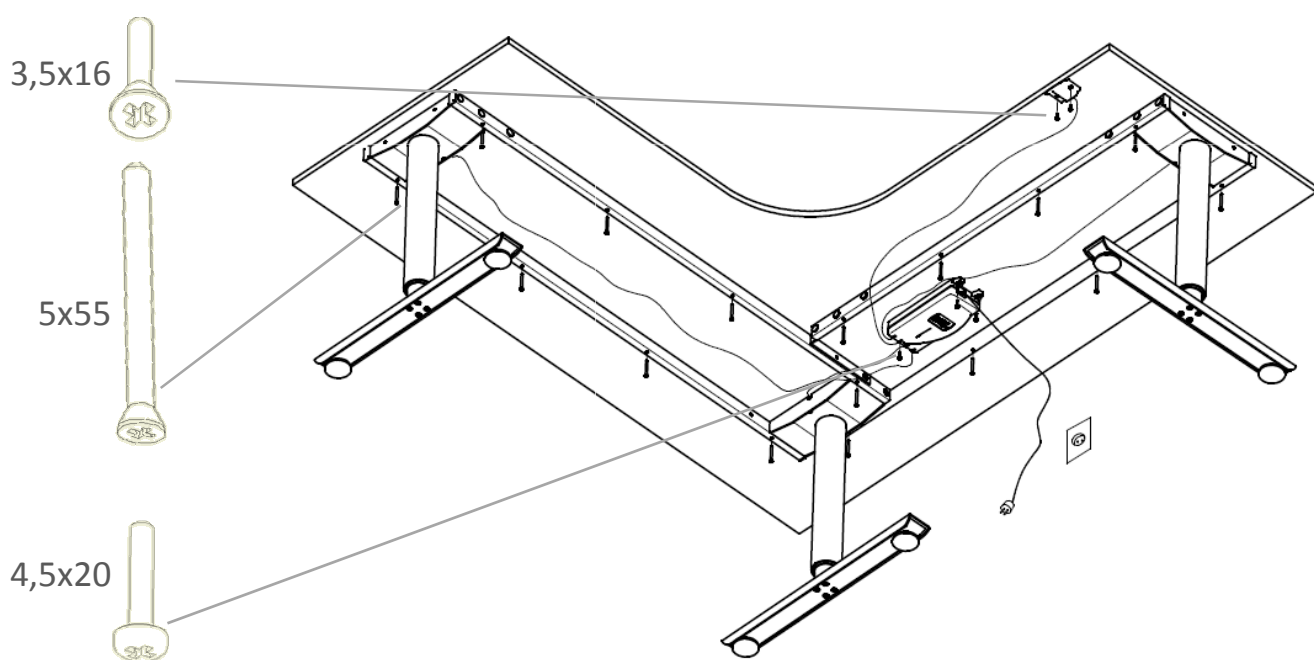
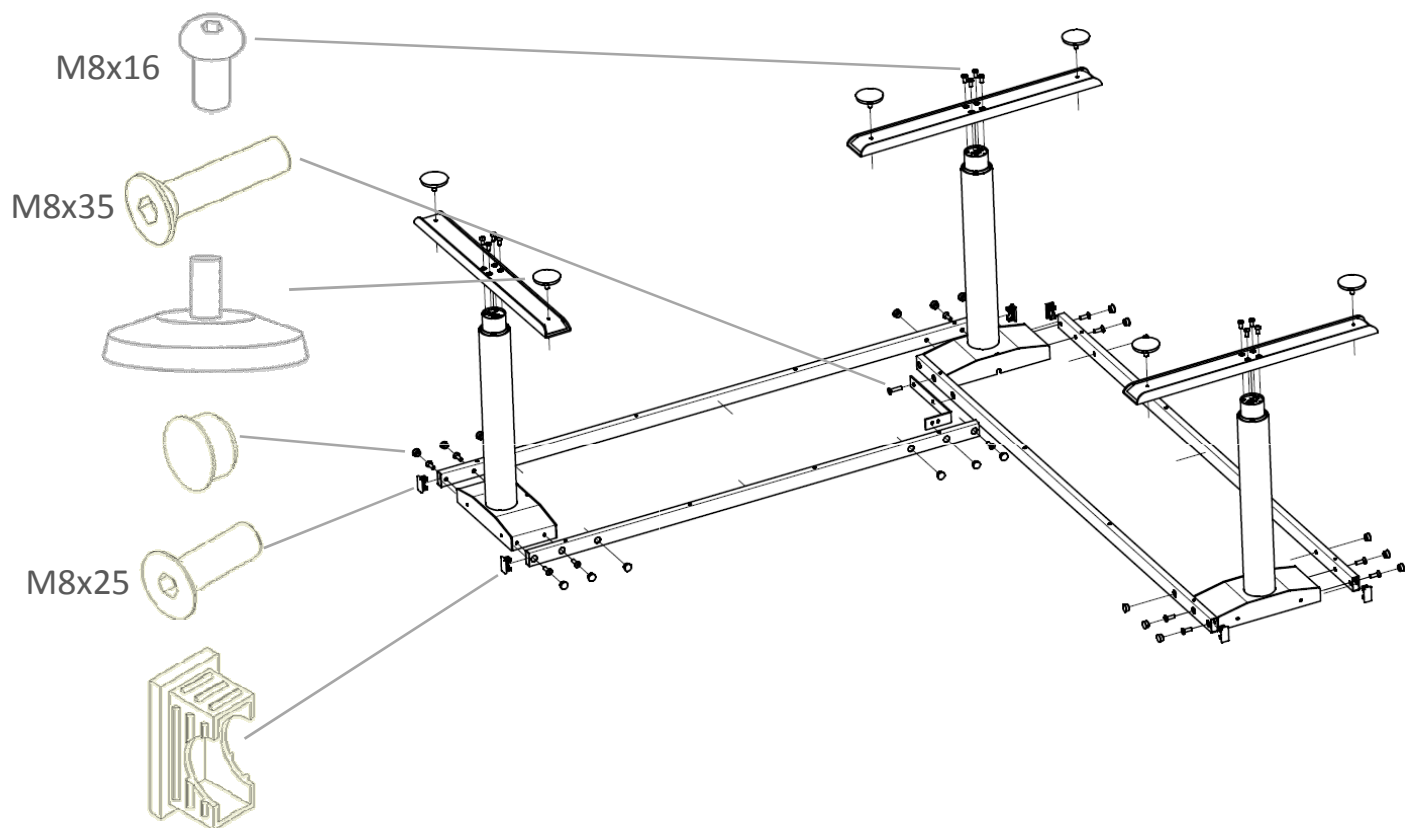



# Assembly Instructions

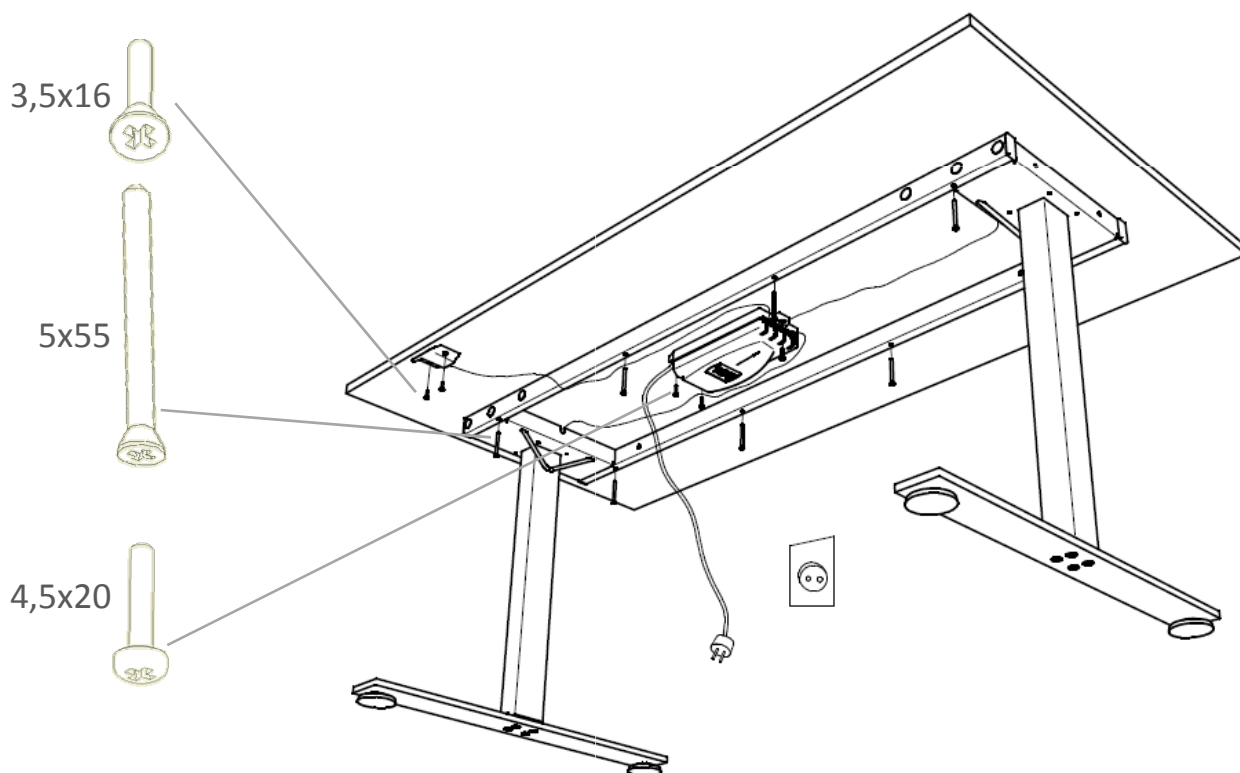
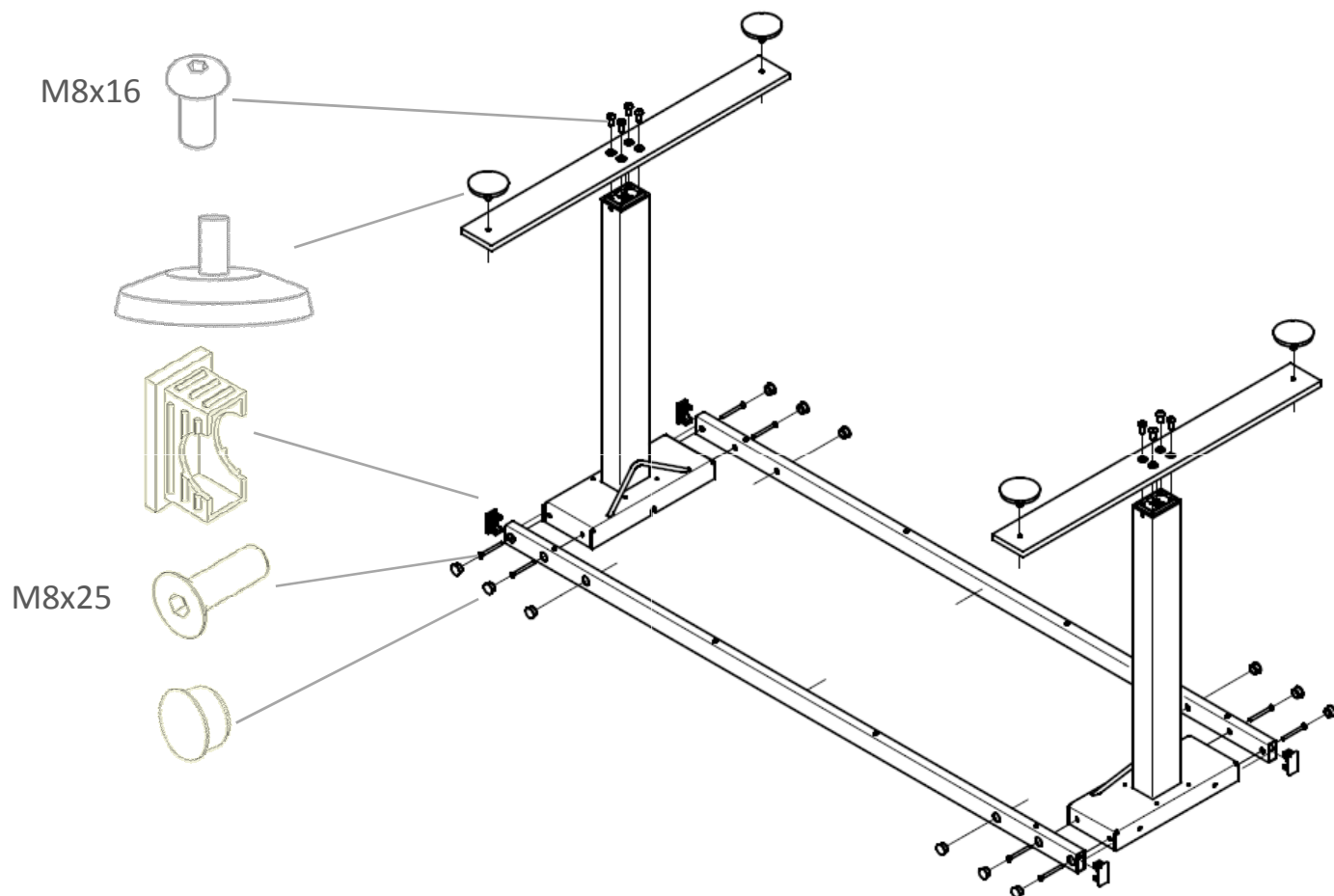

# Assembly Instructions

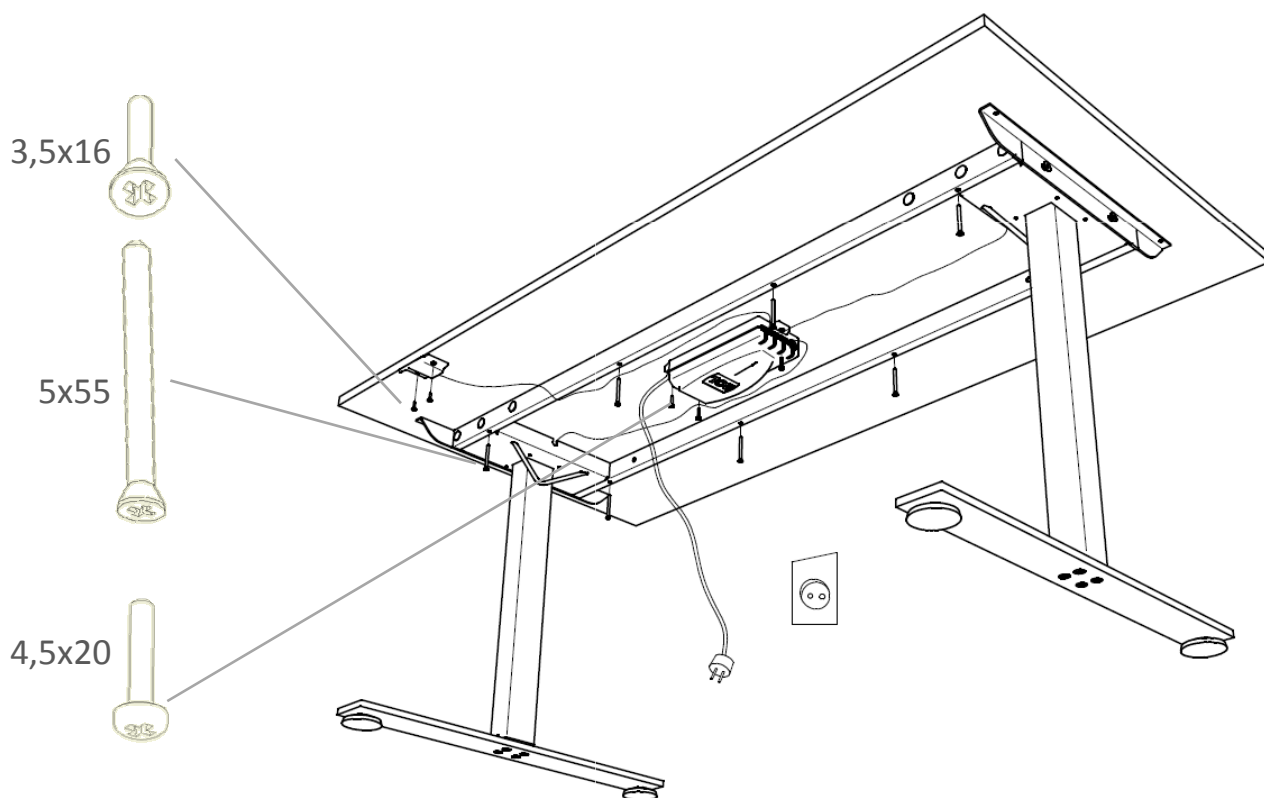
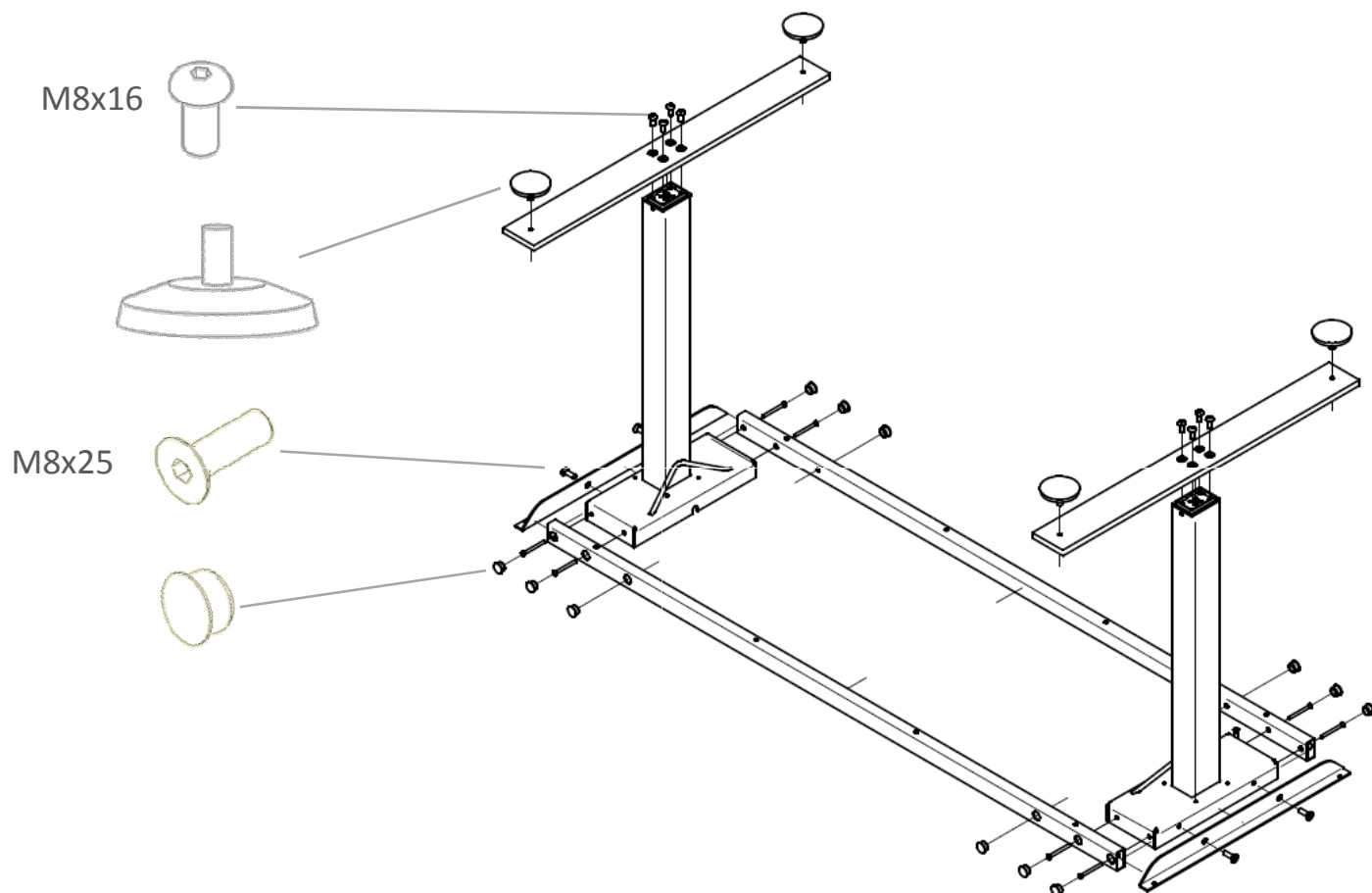

# Assembly Instructions

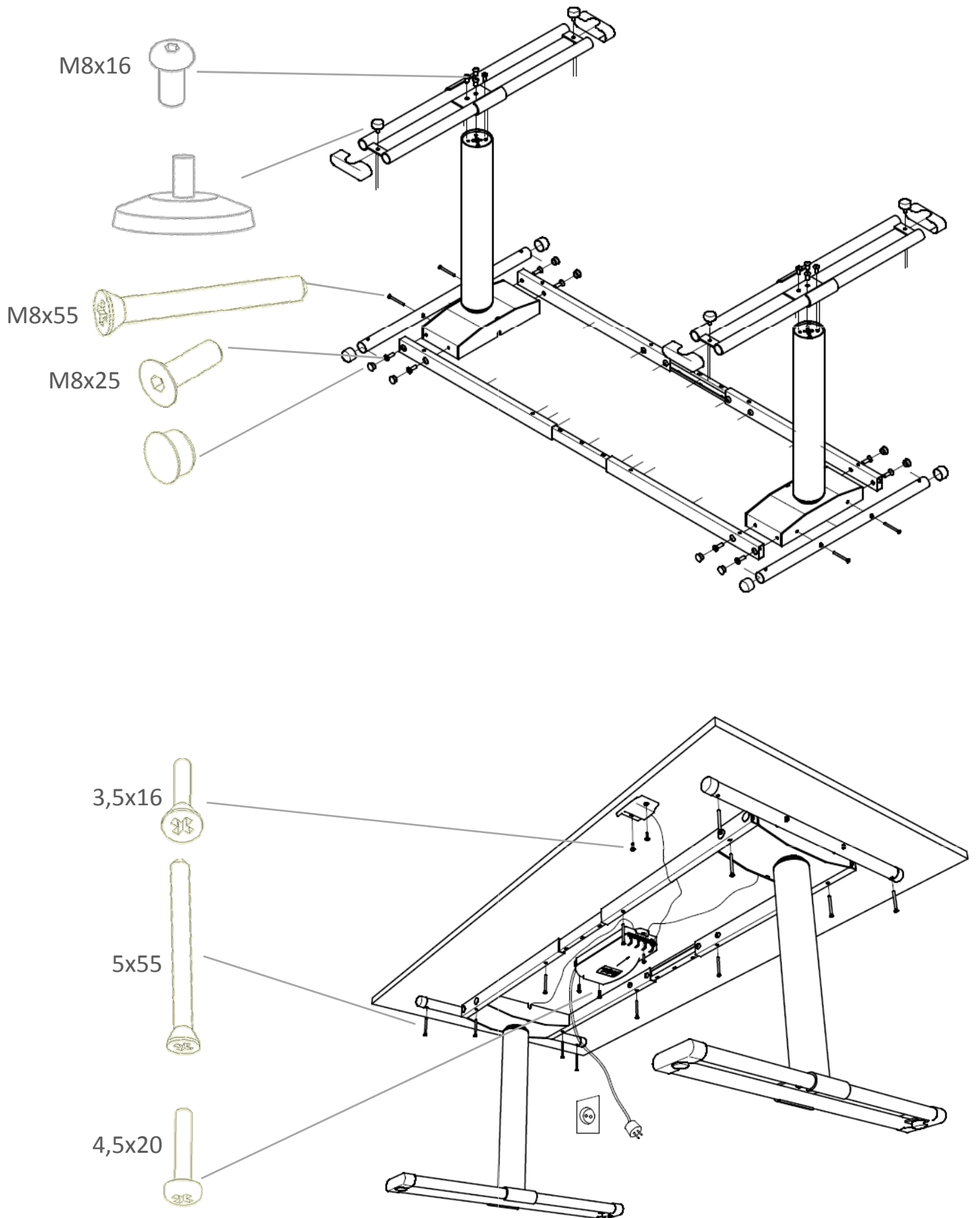

# Assembly Instructions

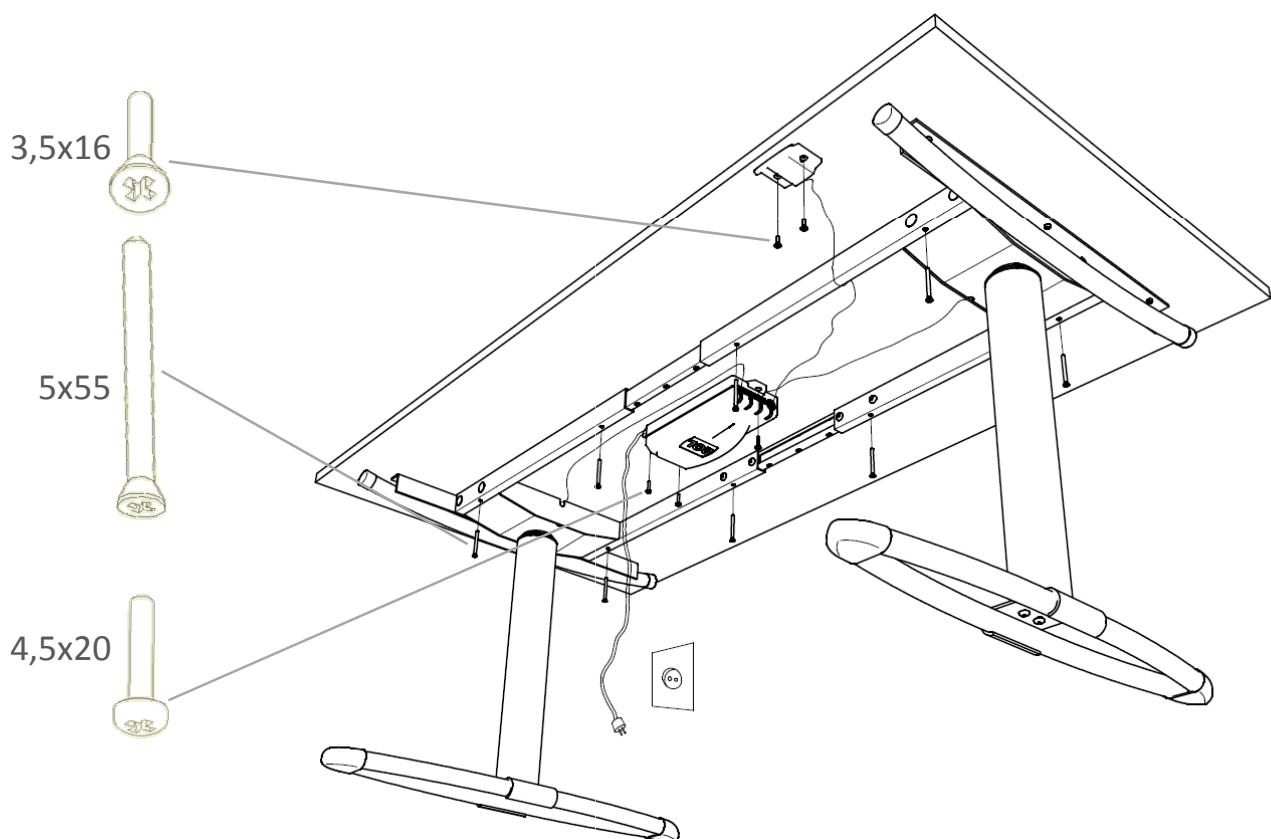
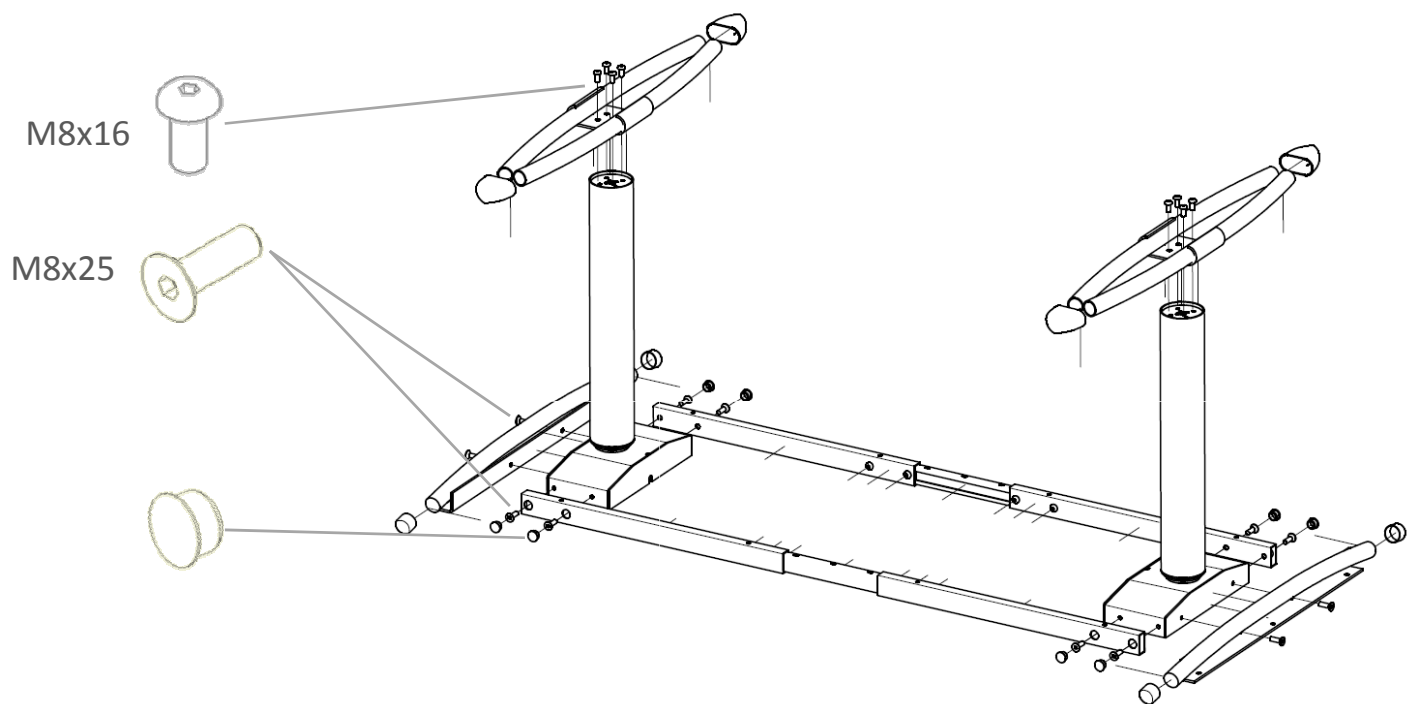

# Assembly Instructions

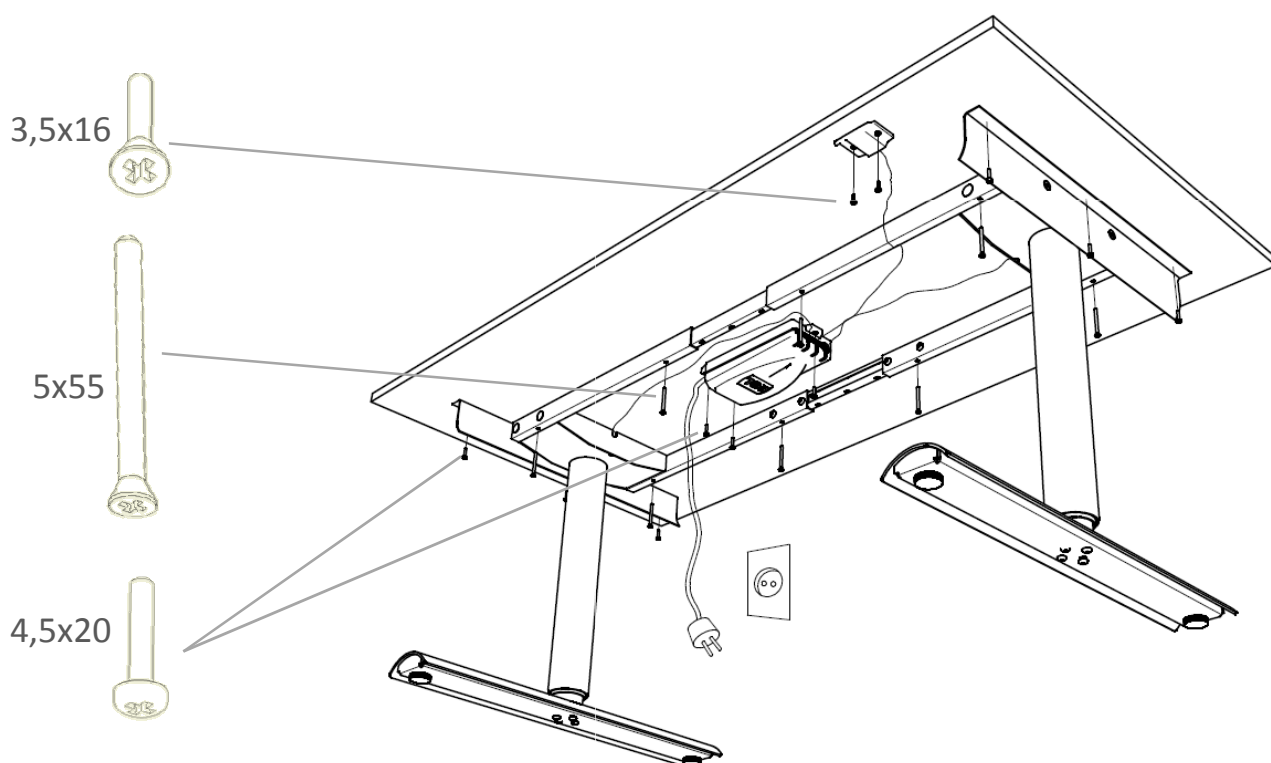
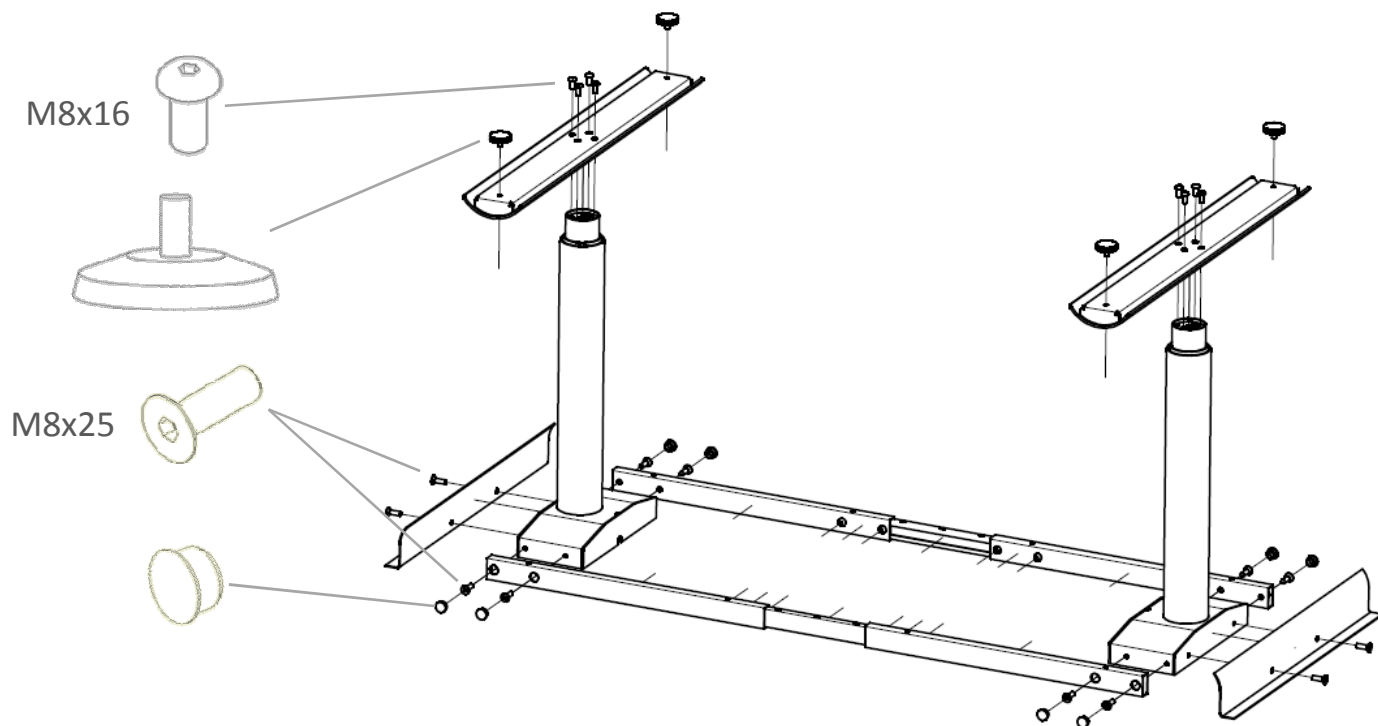



# Assembly Instructions

