

Research Article

Applicability of a 3D Laser Scanner for Characterizing the Spray Distribution Pattern of an Air-Assisted Sprayer

F. Javier García-Ramos , Alfredo Serreta, Antonio Boné, and Mariano Vidal

Escuela Politécnica Superior, University of Zaragoza, C/Cuarte, s/n, 22004 Huesca, Spain

Correspondence should be addressed to F. Javier García-Ramos; fjavier@unizar.es

Received 10 May 2018; Accepted 2 August 2018; Published 12 September 2018

Academic Editor: Annachiara Berardinelli

Copyright © 2018 F. Javier García-Ramos et al. This is an open access article distributed under the Creative Commons Attribution License, which permits unrestricted use, distribution, and reproduction in any medium, provided the original work is properly cited.

Three-dimensional (3D) laser technology has been tested for assessing the performance of air-assisted spraying. A static test using an air-assisted sprayer equipped with two axial fans (front and back) with opposing directions of rotation was developed. The sprayer was adjusted to spread water in a static mode, at a pressure of 10 bars, with four air volumetric flow rates. Measurements were performed using a Leica HDS6000 3D laser scanner. In addition, the flow and velocity of air generated by the air-assisted sprayer were measured using a hot-wire anemometer and a 3D sonic anemometer with the objective of estimating the influence of air flow on the spatial distribution of spray droplets. To carry out the analysis, all of the droplets detected by the laser were considered to be of the same size. The distribution of products was asymmetric when the machine only worked with the back fan, with 41% of the product distributed on the left side versus 59% on the right side, as referenced to the direction of the machine's advance. This asymmetry was corrected when the machine functioned with the two fans activated. These spray data were concordant with the measured air flow generated by the machine in the different working conditions. For the different regulation settings of the machine, taking the vertical of the machine as 0°, the angular region comprised between 40° and 60° was the one that received the highest quantity of product. The increase of the air flow produced a greater distance of the product. For the highest air flow configuration, 99% of the product detected by the laser was detected within a distance of 16 m from the axis of the machine.

1. Introduction

Air-assisted sprayers used in fruit production must be carefully and effectively regulated to ensure that crops are successfully treated. Four main factors affect the deposition efficiency [1, 2]: the nozzle type, fluid pressure, ground speed, and volumetric flow rate of the air. The combination of these parameters determines the applied volume rate. This factor directly influences the quality of the treatment [3].

The use of experimental methods to characterize the product distribution by a sprayer would be difficult and expensive [4]. The characteristics of the plume generated by the sprayer can be simulated by applying integrated computational fluid dynamics (CFD) [5, 6]. However, experimental methods are required to validate such simulations and to determine two critical physical features: first, the deposition

of the product as a function of distance, which is related to the spray drift, and second, the product distribution in the vicinity of the machine, which must be in accordance with the position and geometry of the tree to be treated.

To determine the deposition of the product as a function of distance, quantification tests of the deposition are required through the use of collector elements. Distance of deposition defines the spray drift which is considered as the main source of contamination of pesticide applications in tree crops [7]. Currently, spray drift is measured based on the use of collector elements according to international standards [8]. Alternatively, various technologies can be implemented: laser techniques to obtain the droplet size spectrum and testing with wind tunnels are comparable technologies to predict the field spray deposition [9]. From such measurements, it was reported in [7] that the percentage of deposition in the

ground is reduced exponentially with distance. For this goal, four types of nozzles were tested, both in a wind tunnel and in an axial sprayer working in a citrus orchard.

The pattern of spray deposition is affected by droplet size and air flow. Droplets in flight are often measured using laser-based spatial (number-density weighted) and temporal (number-flux weighted) techniques [10].

The distribution of the spray in the vicinity of the sprayer is often estimated by measuring the air flow generated by the fans. In this sense, the air flow generated by the sprayer can be characterized using high-precision anemometers such as sonic anemometers (two-dimensional or three-dimensional) which are used to measure the velocity components for different heights, sections, and distances from the sprayer [11, 12].

Laser technology has been used successfully to measure the tree canopy geometry in real time with the goal of implementing variable application rate techniques [13–17]; in these measurements, the sensor is embedded on the tractor that performs the crop treatment. Furthermore, laser technology allows real-time monitoring of airborne spray drift, obtaining range-resolved images of the spray plume while requiring fewer personnel and consuming less time than traditional methods, as in the case of light detection and ranging (LIDAR) technology [18]. This technology has been successfully applied to measure the pesticide plumes in fruit orchards [5].

Another application of laser technology is its use in validating equipment design and for analysis of different regulations prior to field trials, as a validation tool for the design of the manufactured prototypes. In this case, the laser can be used statically to analyze the distribution of the product [19].

In conclusion, methodologies used to measure the spray drift and the spray distribution are expensive, time consuming and, in many cases, not practical for the manufacturer's day-to-day tests. For these tests, manufacturers require rapid measurement methods with a reasonable precision to test different configurations of their machines, which, in most cases, have been previously simulated through the use of computational fluid dynamics (CFD). Therefore, an easy estimation of the spray plume generated in the vicinity of the sprayer (maximum distance of deposition of the product and its spatial distribution) for a specific configuration of air flow, nozzle pressure, and nozzle orientation would be of great help to validate key design parameters of the sprayer such as nozzle position, nozzle type, air conducts geometry, and fan regulation.

The present study is aimed at analyzing the viability of using three-dimensional (3D) laser scanner technology to assess the effectiveness of an air-assisted sprayer used in fruit orchards in terms of the two aforementioned critical criteria: the deposition of the product as a function of distance and the product distribution in the vicinity of the machine.

2. Materials and Methods

2.1. Instrumentation. The operation of an air-assisted sprayer equipped with two reversed-rotation axial fans (Gar-melet S.L., Huesca, Spain), one placed behind the tank and the

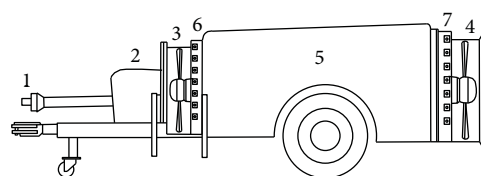

FIGURE 1: Air-assisted sprayer equipped with two reversed-rotation axial fans (1: PTO; 2: pump; 3: front fan; 4: rear fan; 5: tank; 6: front nozzles; 7: rear nozzles).



FIGURE 2: Leica HDS6000 3D laser scanner. (a) Global view; (b) relative position of laser and sprayer during testing.

other placed in front, was analyzed. The diameter of the front fan was 800 mm and that of the back fan was 830 mm. When viewed from the tractor, the front fan spins anticlockwise and the rear fan clockwise. Each fan sucks air axially from the outer area of the machine and expels it radially (Figure 1).

A Leica HDS6000 3D laser scanner (Figure 2) was used to assess the functioning of this sprayer. The 3D laser scanner [19] consists of a pulsed, high-speed laser scanner, with survey-grade accuracy, range, and field of view. It uses a visible green laser beam, with a range of 150–300 m, depending on surface conditions. According to the manufacturer's specifications, the spatial accuracy is 4 mm. The instrument includes a digital camera, which is used to visually determine the region to be scanned in spherical coordinates.

During the scan, the instrument head automatically rotates while a mirror oscillates in the vertical direction. Both movements can be programmed to cover the selected area with user-specified vertical and horizontal angular steps. The angular accuracy (vertical and horizontal) is $60 \mu\text{rad}$. Scanner operations were controlled by a computer, where job specifications were set and data were received and stored. The time required to complete a scanning job depends on the extent of the selected region and on the survey point density.

Under the experimental conditions used in the present study, the equipment surveyed about 1500 points s⁻¹. The laser spot varies according to the distance; at a distance of 50 m, the laser spot is 4 mm in diameter. To detect a particle, the laser scanner must receive about 35% of the emitted energy. Because of this fact, the density of the cloud of drops present in the laser spot affects the sensitivity of the measurement. Tests carried out using LIDAR sensors have shown the difficulty of the laser beam to impact on a less dense cloud, even if these droplets have bigger size [20]. This might result in an underestimation of the amount of droplets at the far end.

TABLE 1: Air flows generated by the sprayer with different configurations of settings and PTO working at 540 rpm.

Activated fans	Fan gear box setting	Blade setting	Air flow (m ³ /h)
Back	Low	3	31,981
		4.5	37,624
Back	High	3	38,654
		4.5	42,831
Back	Low	3	31,981
Front	Low	3	26,635

The scanner registers Cartesian coordinates of the laser reflection point. The precision of the scanner was adjusted such that at a distance of 30 m, data would be recorded every 20 mm. The scanned area was defined through a rectangular window.

Back and front fans can be regulated, in a range labelled 1–5, to supply different air flows from rotating fan blades. The air flows in the present study were measured according to the method given in [21], considering two settings of the fan blade regulation: 3 and 4.5. The air flow corresponding to the back fan was measured at its inlet, using a TESTO 0635 1041 hot-wire anemometer (accuracy 0.03 m/s; range 0–20 m/s). The air flow rate of the front fan was measured at the outlet of the fan because of the presence of the power take off (PTO) of the tractor. Measurements were carried out with the PTO working at 540 rpm.

In addition, the velocity of the air generated by the sprayer was measured in the absence of any wind using a WindMaster 3D sonic anemometer (Gill Instruments, UK) according to the methodology developed by [11]. The accuracy of the sonic anemometer was 1.5% (for wind speeds of up to the maximum measurable value) with an air velocity range of 0 to 45 m/s and a resolution of 0.01 m/s. The air velocity data was recorded at a frequency of 1 Hz. Measurements were carried out with the sprayer static, establishing the same regulations of the fans as those that were selected for the laser tests. The air velocity was measured, based on previous research [22], in the plane corresponding to the back fan of the sprayer. Measurements were made on both sides of the machine at 1.5, 2.5, and 3.5 m from the center of the sprayer for several heights: 1, 2, 3, and 4 m.

2.2. Measurements of Spraying Distribution. Laser measurements were carried out with the sprayer static, establishing three regulations of the fans (Table 1). The sprayer was equipped with 32 Albuz ATR 80° orange nozzles, 16 at the rear and 16 at the front. Tests were carried out at a pressure of 10 bars (1, 39 L/min per nozzle). For each configuration, the laser performed one complete scan.

The droplets (or group of droplets) detected by the laser scanner in each test, referenced with Cartesian coordinates (x, y, z) , were transformed to polar coordinates (V, φ, θ) according to Figure 3, using the center of the rear fan of the sprayer as the center of the coordinate system.

The sprayer was positioned so that the rear fan coincided with the xz plane. In this frame of reference, the machine was

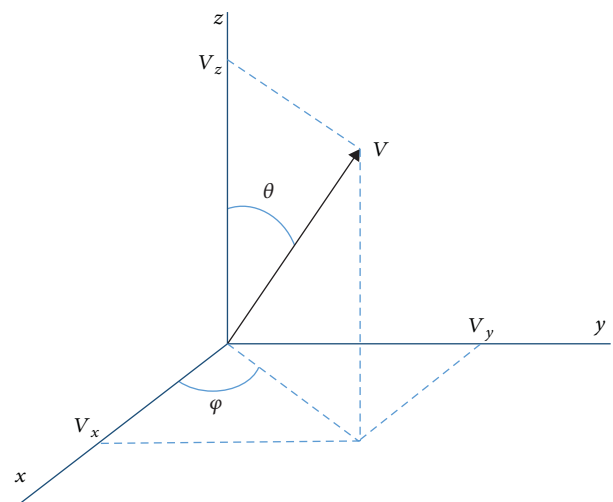

FIGURE 3: Polar coordinates versus Cartesian coordinates.

aligned with the y -axis, so that the tractor was placed in a positive section of that axis and the rear fan of the machine was at the 0 coordinate of the y -axis. The laser was aligned with the machine and located in the negative section of the y -axis, at a distance of 12 m and at a height of 5 m above the sprayer (Figure 2).

Tests carried out on sprayers using LIDAR technology, which has common characteristics to the one used in this test, have shown that measurements cannot be linked to droplet size [23]. In this sense, the 3D scanner cannot differentiate the size of the drops detected. All the drops detected by the laser were considered, as an approximation, to be the same size. Therefore, quantification of products present in the different areas of the 3D space was obtained by counting the number of drops present in each zone.

Considering all drops of the same size requires prior analysis to correctly interpret the information provided by the laser. The droplet population generated by a nozzle presents a great variability in sizes and, at the same time, is conditioned by the working pressure. Among the various parameters used in characterizing the range of droplet sizes in a spray, the most commonly used is the volumetric median diameter (VMD or D50). Additionally, relative span is an indicator of the distribution uniformity. Larger droplets are deposited at a closer distance than smaller ones that are more susceptible to drift. For a specific air velocity, the percentage of product deposited at a given distance is related to an inverse function with D50 [24], being higher for small-diameter droplets.

In order to establish direct correlations between the information supplied by the laser and the volume of product applied at different distances, it would be necessary to carry out quantification tests to collect the quantity of product deposited in different areas near the sprayer. In this article, a first step has been taken to demonstrate the feasibility of the 3D scanner technique in providing relevant information. However, the authors plan to carry out quantification trials in the future in order to obtain complete information to establish precise models for estimating product deposition from the information provided by the laser.

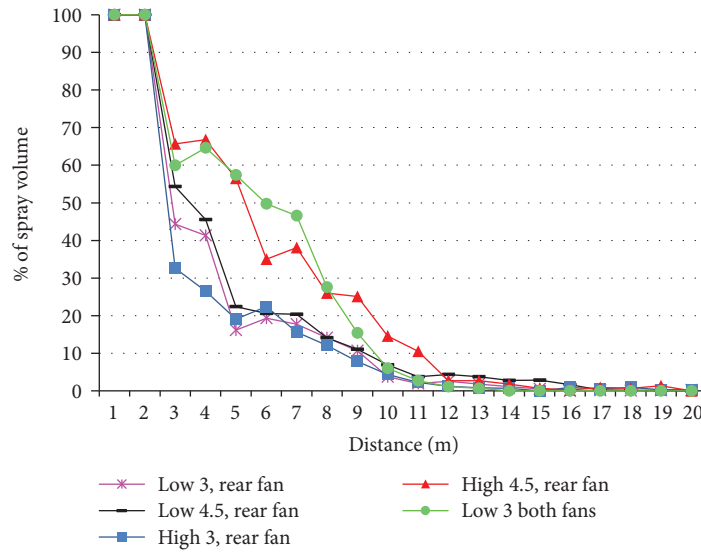

FIGURE 4: Percentage of spray volume detected by the laser within circular crowns of 1 m width for five air flow regulation settings.

Analysis of the experimental data has been carried out leading to three key results: (1) spray deposition as a function of the distance from the machine, (2) symmetry of spray distribution, and (3) spray distribution in angular sectors in a plane (rear fan) perpendicular to the longitudinal axis of the machine.

3. Results and Discussion

3.1. Spray Deposition as a Function of the Distance to the Machine. Considering the center of the rear fan as the coordinate axis, the amount of product applied by the sprayer in circular crowns of 1 m in width was measured.

This methodology allowed the analysis of the spray deposition distance as a function of the regulation of the sprayer. A 100% output of the product from the nozzles was assumed, and using this, the percentage of product that reached the volume of each circular crown was computed.

Figure 4 represents the percentage of product applied as a function of distance for each of the selected regulation settings of the machine. Observing this figure, it becomes clear that the laser technique allows determination of the spray deposition as a function of distance and the quantity of product that reaches distances greater than 16 m was found to be less than 1%. This technique, therefore, should facilitate the establishment of safety distances for the application of phytosanitary products as a function of the regulation of the sprayer.

Moreover, Figure 4 illustrates that the distance of spray deposition varies with regulation of the machine, showing that the air flow directly affects the reach of the sprayer. It can also be seen that the use of two fans allows a greater overall reach of the machine, for the same position of the fan blades (position 3). This fact reveals the interaction between the air flow emitted by the rear fan and that emitted by the front fan.

Results were concordant with those obtained using other methodologies. In [7], the authors report curves of

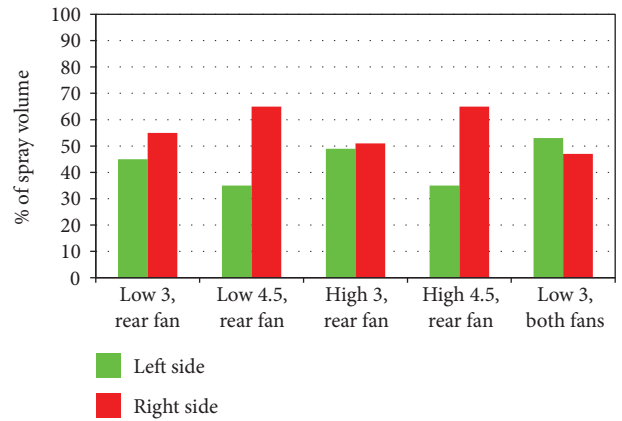

FIGURE 5: Percentage of spray volume detected by the laser on the right and left sides of the sprayer.

sedimenting deposit as percentage of sprayed volume with structures similar to those of Figure 4 (values decreased with distance) from analysis of 10 types of nozzles (5 Albus ATR 80 Grey and 5 Albus TVI 8003 Blue) in a wind tunnel and also as validated in field trials. In the same line, [25] reports values of deposition decreasing with the distance via an acquisition device and a pesticide deposition optical measurement system with an air-assisted spraying system.

3.2. Symmetry of Spray Distribution. The axial fans, due to their direction of rotation, distribute the air flow with some asymmetry, usually applying greater volume of air to the area coincident with the direction of rotation. This fact produces an asymmetry in the spray distribution.

Laser technology was used to assess the symmetry of the spray distribution by quantifying the amount of product applied by the machine to the left and right sectors.

For the data shown in Figure 5, we designate the “right sector” as the one located to the right of the direction of the

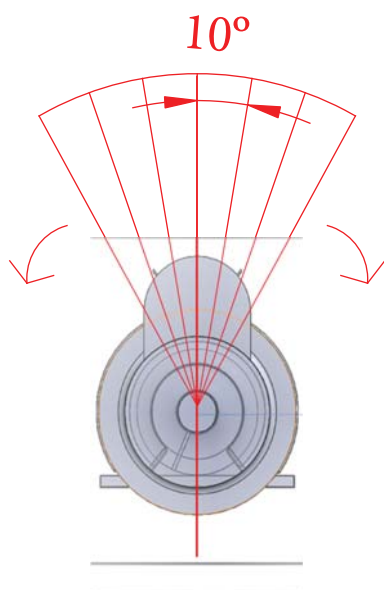

FIGURE 6: Angular sectors used in the analysis of spray direction.

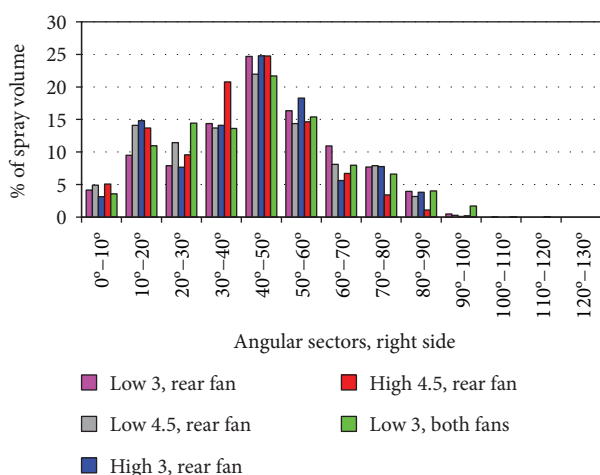

FIGURE 7: Percentage of spray volume for each angular sector for the right side of the sprayer.

advance of the machine. The rear fan of the machine rotates clockwise from the perspective of an observer located at the rear of the machine. Therefore, considering the forward direction of the machine, the rear fan rotates clockwise, theoretically releasing more air to the row of trees located to the right of the advance of the machine.

These results were concordant with those shown in [11], which reported the assessment of the function of a similar sprayer. The asymmetry of the spray distribution was greater working at a blade setting of 4.5 in comparison with a blade setting of 3. The use of two fans with inverted rotation corrected the asymmetry, showing that a design consisting of two fans with opposing rotation improves the homogeneity of the treatment.

3.3. *Spray Distribution in Angular Sectors.* The amount of products applied by the sprayer in angular sectors of a plane

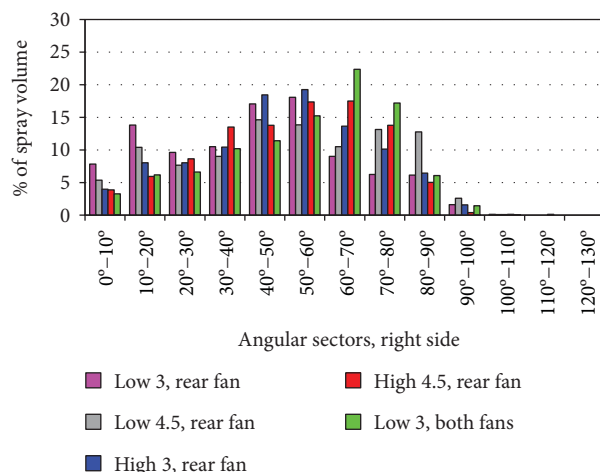

FIGURE 8: Percentage of spray volume for each angular sector for the left side of the sprayer.

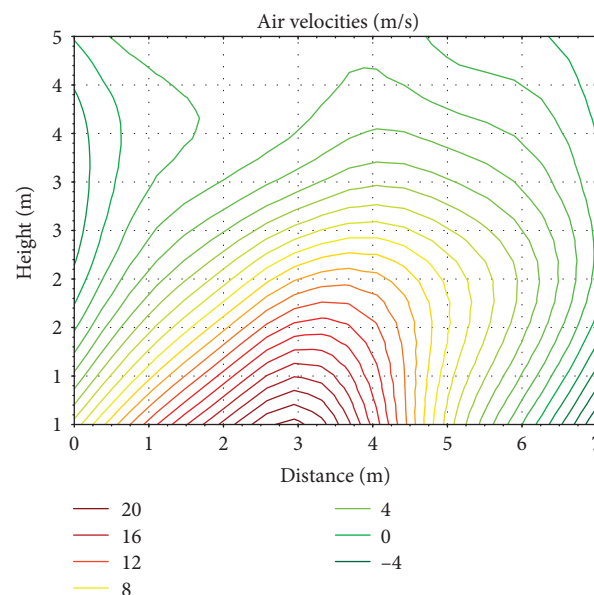

FIGURE 9: Magnitude of air velocity at the plane of the back fan of the sprayer from 3D anemometer measurements, obtained with the sprayer in a low gear and with a blade setting of 4.5.

located at the rear fan was analyzed. For this goal, angular sectors of 10° were used for the left and right sides of the machine, considering the vertical as 0° (Figure 6). The center of the fan was located at 900 mm above the ground.

Figures 7 and 8 show the distribution of spray in the different angular sectors. On both the left and right sides, the greatest amount of product was distributed in the angular sector between 40° and 60°. Considering the geometry of a fruit tree and the designed function of the sprayer, this result is quite logical, because the largest amount of product is directed to the area of greatest vegetation.

According to this result, the laser technique is a useful tool to regulate correctly the position of the nozzles and the direction of the air flow generated by the fans, with the aim

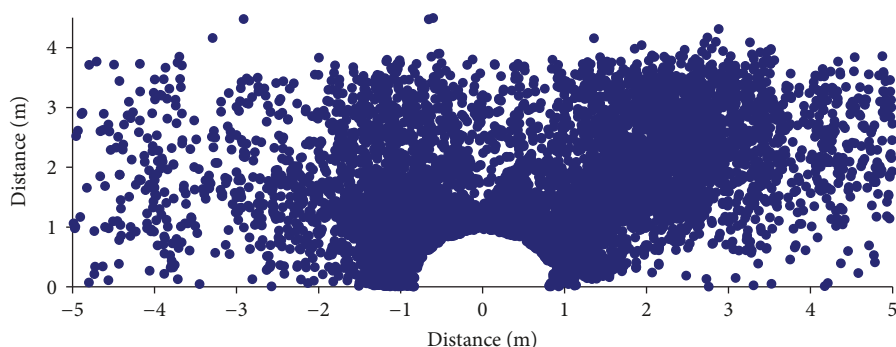

FIGURE 10: Droplets detected by the laser scanner in the plane of the back fan of the sprayer functioning in a low gear and with a blade setting of 4.5.

of directing the pesticide to the canopy of the tree, reducing the spray drift and increasing the efficiency of the treatment.

3.4. Spray Volume versus Air Flow. The laser sensor was capable of estimating the spray volume in the different areas surrounding the sprayer. The measured movement of the product detected by the laser was in agreement with the air flow generated by the sprayer. Figure 9 shows the air velocity pattern generated by the back fan of the sprayer, operating with a low gear and a blade setting of 4.5. The air velocities show an asymmetry with higher velocities on the right side of the machine because of the clockwise rotation of the fan. Figure 10 shows the particles of product detected by the laser for the same configuration. The comparison of the air velocity pattern and the spray volume detected by the laser show a clear correlation between both parameters in accordance with previous studies [26, 27], which have shown that the droplets are blown into the fruit tree canopy by the forced air.

The flow rate of liquid supplied by the equipment was constant during all the tests as the working pressure was set at 10 bars. However, when comparing the number of droplets obtained for different air flows, the number of droplets detected at high speed of the fan was 36.8% lower than that at low speed for blade setting 3 and 40.4% lower considering blade setting 4.5. Analyzing the number of droplets detected at a distance of 7 to 12 m, the number of droplets detected at high speed of the fan was 32.7% lower than that at the low one, at blade setting 3, and 53.4% considering blade setting 4.5. These data are consistent with those obtained by [20], which in tests conducted with a LIDAR on board a vehicle detected a greater number of spray droplets for low air flows than for high ones. This fact could also support the fact that the lower the density of the droplet cloud, the greater the difficulty of the laser in determining it, as also it was concluded by [20].

4. Conclusions

The laser technique examined in this study provides useful information on of air-assisted sprayers for evaluating their function with the aim of improving efficiency of application in the field.

Measurements using the laser sensor allowed the quantification of the maximum distance of deposition of the product. Such data facilitates quantification of the risk of drift and, therefore, the risk of contamination of elements adjacent to the treatment plot: water channels, populations, roads, farms, orchards, and so on.

The left-right asymmetry of the spraying can be estimated in a straightforward manner for the different configurations of the fans. Furthermore, the laser allows quantification of the amount of products applied in different areas in the vicinity of the sprayer. The results of this study also showed that information supplied by the laser on the spraying pattern is concordant with the air flow pattern of the sprayer as measured using 3D anemometers.

When considered together, our results indicate that laser technology can be used for the validation of sprayer machine design. Moreover, as the next step, the regulation of the function of the sprayer, depending on the vegetative state of the crop and the geometry of the orchard, can be established and checked. The air flow, air direction, fan setting, pressure, nozzle type, and nozzle position can be optimized using this laser technique.

Data Availability

The “excel spreadsheet format” data used to support the findings of this study may be released upon application to the main author of the research (F. Javier García-Ramos), who can be contacted by email at fjavier@unizar.es or by post mail at Escuela Politécnica Superior, University of Zaragoza, C/Cuarte, s/n, 22004, Huesca, Spain.

Conflicts of Interest

The authors declare that they have no conflicts of interest.

References

- [1] M. Farooq, R. Balachandar, D. Wulfshon, and T. M. Wolf, “PA—precision agriculture: agricultural sprays in cross-flow and drift,” *Journal of Agricultural Engineering Research*, vol. 78, no. 4, pp. 347–358, 2001.

- [2] Y. M. Koo, M. Salyani, and J. D. Whitney, "Spray variable effects on abscission of oranges fruits for mechanical harvesting," *Transactions of the ASAE*, vol. 43, no. 5, pp. 1067–1073, 2000.
- [3] J. V. Cross, P. J. Walklate, R. A. Murray, and G. M. Richardson, "Spray deposits and losses in different sized apple trees from an axial fan orchard sprayer: 1. Effects of spray liquid flow rate," *Crop Protection*, vol. 20, no. 1, pp. 13–30, 2001.
- [4] D. Dekeyser, A. T. Duga, P. Verboven, A. M. Endalew, N. Hendricks, and D. Nuyttens, "Assessment of orchard sprayers using laboratory experiments and computational fluid dynamics modelling," *Biosystems Engineering*, vol. 114, no. 2, pp. 157–169, 2013.
- [5] A. M. Endalew, C. Debaer, N. Rutten et al., "Modelling pesticide flow and deposition from air-assisted orchard spraying in orchards: a new integrated CFD approach," *Agricultural and Forest Meteorology*, vol. 150, no. 10, pp. 1383–1392, 2010.
- [6] F. J. García-Ramos, H. Malón, A. Javier Aguirre, A. Boné, J. Puyuelo, and M. Vidal, "Validation of a CFD model by using 3D sonic anemometers to analyse the air velocity generated by an air-assisted sprayer equipped with two axial fans," *Sensors*, vol. 15, no. 2, pp. 2399–2418, 2015.
- [7] X. Torrent, C. Garcerá, E. Moltó et al., "Comparison between standard and drift reducing nozzles for pesticide application in citrus: part I. Effects on wind tunnel and field spray drift," *Crop Protection*, vol. 96, pp. 130–143, 2017.
- [8] ISO 22866, 2005, *Equipment for Crop Protection - Methods for Field Measurement of Spray Drift*, International Organization for Standardization, Geneva, Switzerland, 2000.
- [9] D. Nuyttens, M. De Schampheleire, K. Baetens, and B. Sonck, "Comparison of different drift risk assessment means," *Aspects of Applied Biology*, vol. 84, 2008.
- [10] E. Hilz and A. W. P. Vermeer, "Spray drift review: the extent to which a formulation can contribute to spray drift reduction," *Crop Protection*, vol. 44, pp. 75–83, 2013.
- [11] F. J. García-Ramos, M. Vidal, A. Boné, H. Malón, and J. Aguirre, "Analysis of the air flow generated by an air-assisted sprayer equipped with two axial fans using a 3D sonic anemometer," *Sensors*, vol. 12, no. 6, pp. 7598–7613, 2012.
- [12] F. Lebeau, A. Verstraete, C. Stainier, and M. F. Destain, "RTDrift: a real time model for estimating spray drift from ground applications," *Computers and Electronics in Agriculture*, vol. 77, no. 2, pp. 161–174, 2011.
- [13] S. D. Tumbo, M. Salyani, J. D. Whitney, T. A. Wheaton, and W. M. Miller, "Investigation of laser and ultrasonic ranging sensors for measurements of citrus canopy volume," *Applied Engineering in Agriculture*, vol. 18, no. 3, pp. 367–372, 2002.
- [14] P. Balsari, G. Doruchowski, P. Marucco, M. Tamagnone, J. C. van de Zande, and M. Wenneker, "A system for adjusting the spray application to the target characteristics," *Agricultural Engineering International CIGR*, vol. 10, pp. 1–11, 2008.
- [15] J. Llorens, E. Gil, J. Llop, and A. Escolà, "Ultrasonic and LIDAR sensors for electronic canopy characterization in vineyards: advances to improve pesticide application methods," *Sensors*, vol. 11, no. 2, pp. 2177–2194, 2011.
- [16] P. Berk, M. Hocevar, D. Stajko, and A. Belsak, "Development of alternative plant protection product application techniques in orchards, based on measurement sensing systems: a review," *Computers and Electronics in Agriculture*, vol. 124, pp. 273–288, 2016.
- [17] H. Liu and H. Zhu, "Evaluation of a laser scanning sensor in detection of complex-shaped targets for variable-rate sprayer development," *Transactions of the ASABE*, vol. 59, no. 5, pp. 1181–1192, 2016.
- [18] E. Gregorio, J. R. Rosell-Polo, R. Sanz et al., "LIDAR as an alternative to passive collectors to measure pesticide spray drift," *Atmospheric Environment*, vol. 82, pp. 83–93, 2014.
- [19] F. J. García-Ramos, A. Boné, A. Serreta, and M. Vidal, "Application of a 3-D laser scanner for characterising centrifugal fertiliser spreaders," *Biosystems Engineering*, vol. 113, no. 1, pp. 33–41, 2012.
- [20] E. Gil, J. Llorens, J. Llop, X. Fàbregas, and M. Gallart, "Use of a terrestrial LIDAR sensor for drift detection in vineyard spraying," *Sensors*, vol. 13, no. 1, pp. 516–534, 2013.
- [21] ISO 9898, 2000, *Equipment for Crop Protection—Test Methods for Air-Assisted Sprayers for Bush and Tree Crops*, Geneva, Switzerland, International Organization for Standardization, 2000.
- [22] A. de Moor and J. Langenakens, "Dynamic air velocity measurements of air-assisted sprayers in relation to static measurements," *Aspects of Applied Biology*, vol. 66, pp. 309–322, 2002.
- [23] R. Sanz-Cortiella, J. Llorens-Calveras, J. R. Rosell-Polo, E. Gregorio-Lopez, and J. Palacin-Roca, "Characterisation of the LMS200 laser beam under the influence of blockage surfaces. Influence on 3D scanning of tree orchards," *Sensors*, vol. 11, no. 3, pp. 2751–2772, 2011.
- [24] J. P. Douzals and M. P. Chalendard, "Vertical and horizontal spray distribution of hollow cone nozzles in a wind tunnel: a preliminary study to mitigate spray drift in orchard applications," in *SuproFruit 2015, 13th Workshop on spray application techniques in fruit growing*, vol. 448, pp. 32–34, Lindau, Germany, July 2015.
- [25] Z. Changyuan, Z. Chunjiang, W. Xiu, L. Wei, L. Wei, and Z. Ruixiang, "Nozzle test system for droplet deposition characteristics of orchard air-assisted sprayer and its application," *International Journal of Agricultural and Biological Engineering*, vol. 7, no. 2, pp. 122–129, 2014.
- [26] N. Pai, M. Salyani, and R. D. Sweeb, "Regulating airflow of orchard air-blast sprayer based on tree foliage density," *Transactions of the ASABE*, vol. 52, no. 5, pp. 1423–1428, 2009.
- [27] F. F. Dai, "Selection and calculation of the blowing rate of air assisted sprayers," *Plant Protection*, vol. 34, no. 6, pp. 124–127, 2008.

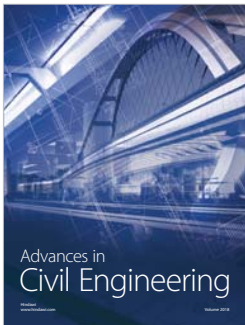
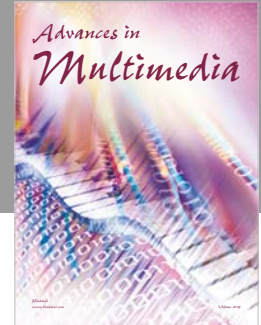
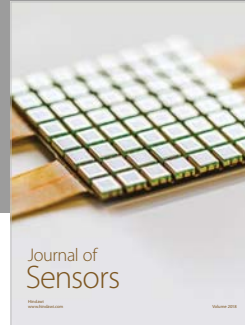
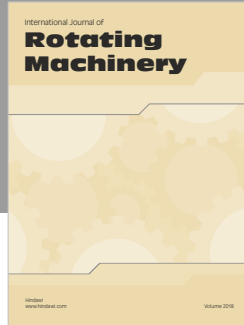

Hindawi

Submit your manuscripts at
www.hindawi.com

