

A Versatile Resonant Tank Identification Methodology for Induction Heating Systems

H. Sarnago, *Member, IEEE*, O. Lucía, *Senior Member, IEEE*,
and J.M. Burdio, *Senior Member, IEEE*.

Abstract- Induction heating has become the most advance heating process due to benefits such as efficiency, performance, cleanness and safety. In this process, the electromagnetic coupling between the induction coil and the induction target is key, determining the heating performance as well as the resonant power converter operation. This paper proposes an accurate and cost-effective resonant tank identification method applied to induction heating systems. It is based on monitoring the resonant capacitor voltage in order to calculate the resonant tank quality factor. The proposed methodology has been tested using a versatile power electronics test-bench applied to domestic induction heating, proving the feasibility of this proposal.

Keywords – Induction heating, home appliances, resonant power conversion, inverters.

I. INTRODUCTION

Induction heating (IH) has become the heating technology of choice in many industrial [1], domestic [2] and medical applications [3] due to its benefits in terms of efficiency cleanliness and performance, leading to a superior quality process [4]. Regardless the application, IH is based on applying an alternating magnetic field to an induction target to be heated. Consequently, the main heating mechanism in industrial and domestic applications relies on the induced *Eddy currents* which heats the induction target by *Joule* effect. In this phenomenon, as it occurs in most wireless power transfer systems [5], the electromagnetic coupling between the induction coil and the induction target is essential (Fig. 1), since it determines the induction heating process as well as the power converter operating point. It depends strongly on the geometry and relative position of the elements, the excitation frequency, temperature, and materials, among other factors.

Most modern IH systems rely on the use of resonant power converters due to its advantages in terms of efficiency and performance due to the soft-switching operation and low harmonic emissions. Thus, the induction heating load is part of the resonant tank and, consequently, severely affects the power converter operation and its performance. Therefore, an accurate identification of the main induction heating target characteristics is essential to ensure, not only the proper system performance, but also to ensure is reliability [6, 7].

The aim of this paper is to propose an accurate and cost-effective resonant tank identification system applied to induction heating system. The proposed system relies on measuring the resonant capacitor voltage in order to calculate



Fig. 1. Induction heating coils with different electromagnetic coupling ratio to the induction heating target.

the resonant tank quality factor, providing useful information about the electromagnetic coupling. This enables to detect the presence of an IH load as well as the coverage ratio in order to optimize the heating process by adapting the control algorithm to changes in the plant [6] or adapt the output power of partly covered coils to optimize the heat distribution in the pot. Besides, the proposed measurement technique avoids the need for commonly used costly and bulky current transformers. The remainder of this paper is organized as follows. Section II details the proposed induction heating load detection system, including the resonant power converter, calculation methodology, and digital implementation. Section III summarizes the main implementation and experimental results performed with a versatile power electronics test bench and different operating conditions. Finally, Section IV draws the main conclusions of this paper.

II. PROPOSED INDUCTION HEATING LOAD DETECTION SYSTEM

A. Resonant power converter

Modern IH systems are based on resonant power converters due to their benefits in terms of performance and efficiency. Among the available resonant topologies [4, 8-10], the class-D topologies [11] are generally preferred due to their balanced performance operation and cost. Fig. 2 (a) shows the schematic of the half-bridge series resonant converter, which is commonly applied to domestic induction heating. It is composed of two unipolar bidirectional devices, commonly IGBTs with anti-parallel diodes and the resonant tank. The resonant tank is composed of the induction heating target, modeled as the series connection of a resistor R_L and an inductor, L_r , and the resonant capacitor C_r [12]. When the IH load changes, i.e. geometry, coupling, materials, or temperature, both R_L and L_r are modified.

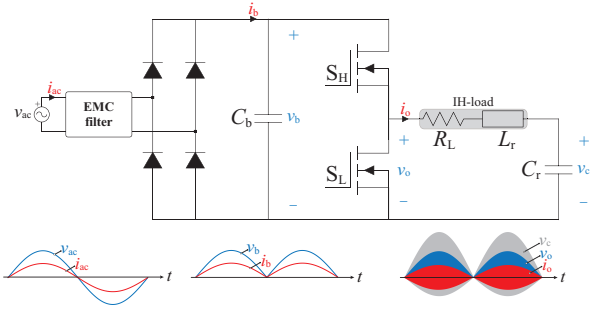

Fig. 2. Half-bridge series resonant inverter: schematic and main waveforms.

In order to quantify the IH load change, the quality factor, as defined later, is preferred because it is approximately constant in the operating range and offers useful information about the IH load [13], enabling to design accurate converter control and safe operating conditions [6]. Fig. 2 (b) shows the main waveforms including the control signals, output voltage and current, and resonant capacitor voltage. The series resonant half-bridge inverter is usually designed to operate above the resonant frequency to achieve zero voltage switching, and the output power is controlled by increasing the switching frequency.

B. Identification method

The proposed detection method is based on analyzing the changes in the resonant network previously detailed. For a series-resonant inverter, the resonant frequency ω_o is defined as

$$\omega_o = \frac{1}{\sqrt{L_r C_r}} \quad (1)$$

The quality factor Q is a dimensionless parameter that characterizes the circuit bandwidth and which enables to accurately detect the main features of the IH target. In this circuit, it can be defined at a given switching frequency ω_{sw} as

$$Q_{sw} = \frac{\omega_{sw} L_r}{R_L} \quad (2)$$

In order to calculate the electrical equivalent parameters, several methods have been proposed in the past, including frequency-domain approaches [14], dedicated test-benches [15], and output-power characterization [16]. However, these approaches require often several measurements as well as complex post processing requiring intensive computing power. The proposed approach calculates the quality factor by measuring only the resonant capacitor voltage, which can be performed using cost-effective passive elements and ADCs.

Considering as initial point equation (2), the equivalent IH load resistance can be calculated using

$$R_L = \frac{P_o}{I_{o,rms}^2}, \quad (3)$$

where $I_{o,rms}$ is the RMS inverter output current. Considering the series resonant tank and steady state assuming $T_{sw} \ll T_{ac}$, the output current can be calculated using partial integration as follows:

$$I_{o,rms}^2 = \frac{1}{T_{sw}} \int_{T_{sw}} i_o^2 dt = \frac{1}{T_{sw}} i_o|_0^{T_{sw}} \int_{T_{sw}} i_o dt - \frac{1}{T_{sw}} \int_{T_{sw}} \left(\frac{di_o}{dt} \right) \left(\int i_o dt \right) dt, \quad (4)$$

where the integral part can be expressed as a function of the circuit voltages and the resonant elements using the following expression:

$$I_{o,rms}^2 = -\frac{1}{T_{sw}} \int_{T_{sw}} \left(\frac{di_o}{dt} \right) \left(\int i_o dt \right) dt = -\frac{C_r}{L_r} \frac{1}{T_{sw}} \int_{T_{sw}} v_c (v_o - v_c - R_L i_o) dt. \quad (5)$$

Finally, by analyzing each one of the integral terms, this expression can be simplified to be only a function of the resonant capacitor voltage and the dc-link voltage, V_s

$$I_{o,rms}^2 = -\frac{C_r}{L_r} \frac{1}{T_{sw}} \left(\int_{T_{sw}} v_c v_o dt - \int_{T_{sw}} v_c v_c dt - R_L \int_{T_{sw}} v_c i_o dt \right) = \quad (6)$$

$$= \frac{C_r}{L_r} \left(V_{c,rms}^2 - \frac{V_s}{T_{sw}} \int_0^{DT_{sw}} v_c(t) dt \right).$$

Consequently, combining expressions (3) and (6) in (2), the quality factor can be calculated as a function of the resonant capacitor voltage and the output power.

$$Q_{sw} = \frac{\omega_{sw} L_r I_{o,rms}^2}{P_o} = \frac{\omega_{sw} C_r \left(V_{c,rms}^2 - \frac{V_s}{T_{sw}} \int_0^{DT_{sw}} v_c(t) dt \right)}{P_o}. \quad (7)$$

Finally, by expressing the output power as a function of the resonant capacitor voltage [17],

$$P_o = f_{sw} C_r V_s (v_c(t=0) - v_c(t=DT_{sw})), \quad (8)$$

and assuming a square wave modulation, i.e. $D=0.5$, $V_s = (v_c(t=0) + v_c(t=DT_{sw}))$, the previous equation can be rewritten in a form depending only on v_c as follows:

$$Q_{sw} = \frac{\omega_{sw} C_r \left(V_{c,rms}^2 - \frac{V_s}{T_{sw}} \int_0^{DT_{sw}} v_c(t) dt \right)}{P_o} = \quad (9)$$

$$2\pi \frac{\left(V_{c,rms}^2 - (v_c(t=0) + v_c(t=DT_{sw})) \left(\frac{1}{T_{sw}} \int_0^{DT_{sw}} v_c(t) dt \right) \right)}{(v_c(t=0) + v_c(t=DT_{sw})) (v_c(t=0) - v_c(t=DT_{sw}))}.$$

Where $v_c(t=0)$ and $v_c(t=DT_{sw})$ are the values of the resonant capacitor voltage at the turn-off transitions of S_H and S_L , respectively.

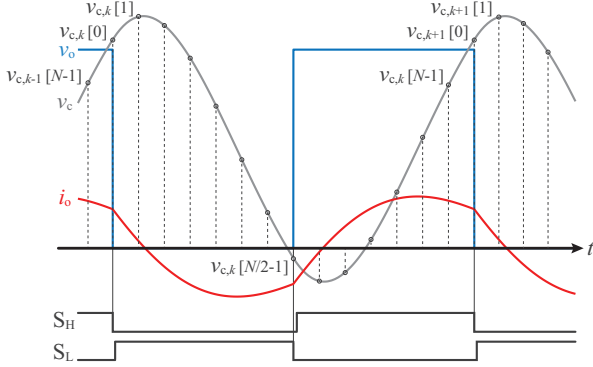

Fig. 3. Resonant converter main waveforms and sampling points.

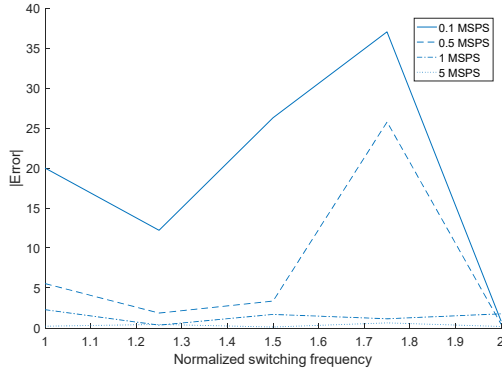

Fig. 4. Quality factor estimation error vs sampling rate for different sampling rates.

Digital implementation

In order to provide a suitable approach for digital implementation, the resonant capacitor voltage must be measured and equation discretized. The resonant capacitor voltage is sampled using a resistor voltage divider as shown in Fig. 3, where a switching period k with N samples is represented. It is important to note that the points $v_{c,k}[0]$ and $v_{c,k}[N/2-1]$ are key to calculate the output power and, consequently, the quality factor.

Expression (9) can be discretized to be calculated as follows

$$Q_{sw,k} = \frac{2\pi}{N} \left(\frac{\sum_{n=0}^{N-1} v_{c,k}^2[n] - (v_{c,k}[0] + v_{c,k}[N/2-1]) \sum_{n=0}^{N/2-1} v_{c,k}[n]}{v_{c,k}^2[0] - v_{c,k}^2[N/2-1]} \right). \quad (10)$$

Finally, the average quality factor over a mains period, $T_{ac}=1/f_{ac}$, results, $Q_{sw,avg} = \frac{1}{K} \sum_{k=0}^{K-1} Q_{sw,k}$, where K denotes the number of switching periods during a mains period, $K=f_{sw}/f_{ac}$. It is important to note that this expression depends only on

the resonant capacitor voltage, providing a versatile and cost-effective method to estimate the induction heating load through its quality factor.

There are two main elements to be considered when analyzing the accuracy of the proposed method. The first one is the tolerance in the resonant capacitor value, which must be typically calibrated for each batch during the production process. The second one implies the optimization of the trade-off between cost and error in the selection of the ADC sampling rate Fig. 4 shows the error vs sampling rate for a typical induction heating load ($R_L=12 \Omega$, $L_r=180 \mu\text{H}$ and $C_r=78 \text{ nF}$). From this figure, it is clear that errors below the 5% can be obtained in the entire operation range.

III. EXPERIMENTAL RESULTS

In order to prove the feasibility of the proposed identification system, a versatile power converter has been designed and implemented (Fig. 5). It is a MOSFET-based implementation enabling the implementation of 4 half-bridge branches which are controlled using a versatile FPGA-based control architecture. The resonant capacitor voltage is measured using inexpensive voltage-divider resistors and 1-MSPS 10-bit ADC converter.

Fig. 6 shows the main experimental waveforms including the output voltage, current and resonant capacitor voltage for an induction heating load with different coverage ratios, i.e. electromagnetic coupling. In this figure, the changes in bus voltage and coil current under different coverage ratio can be seen. Besides, it can be clearly seen that the measurement of the resonant capacitor voltage, which contains lower harmonic content, provides an straight-forward implementation. The variation in the resonant capacitor voltage evaluated using expression (7) enables calculating the quality factor in order to estimate the IH load.

In Fig. 7, the error results comparing the proposed implementation and the results obtained using a LeCroy HDO8000 12-bit digital oscilloscope have been added for the same operation points shown in Fig. 6. These results prove experimentally the accuracy of the proposed implementation.

Finally, Fig. 8 summarizes the experimentally calculated quality factors Q_{sw} using the detailed test-bench for different materials, including aluminum pots and air, and different coverage ratios. Different materials, i.e. IH load 1 – 3, have been tested using 8-cm inductors and different coverage radii as shown in Fig. 5 It is important to remark that the proposed technique enables to distinguish materials not to be heated. i.e. aluminum or air, from working materials and, more importantly, the coverage ratio in order to adapt the output power to improve the heating process. parameters enable to optimize the power converter operation, optimizing its reliability and performance. Besides, the proposed technique is based on measuring the resonant capacitor voltage, avoiding the need of expensive and bulky current transformers, which limits the current state-of-the-art implementations.

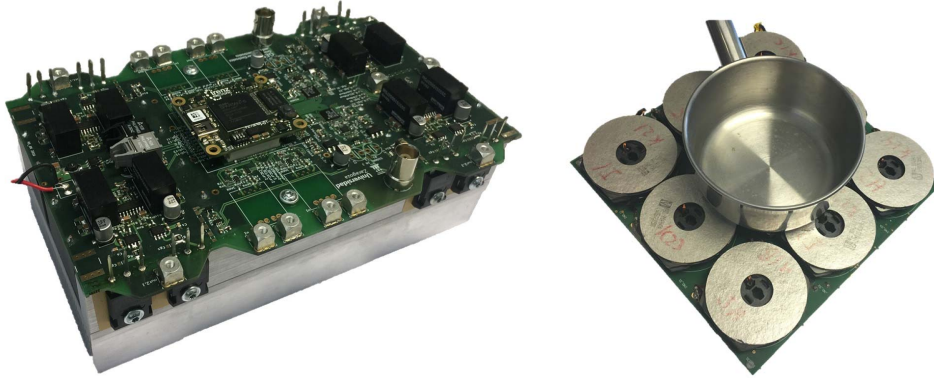

Fig. 5. Experimental test-bench including power converter and induction target.

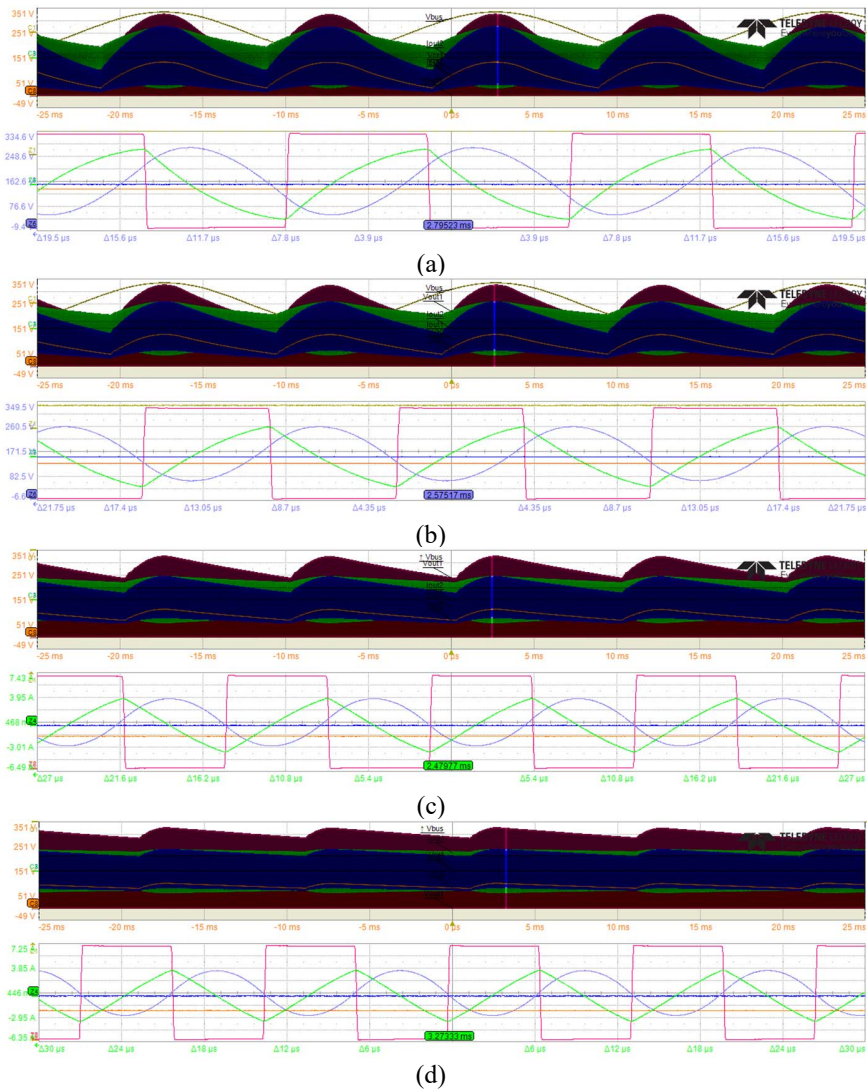

Fig. 6. Main experimental waveforms for different coverage ratios: (a) Fully covered $Q_{sw} = 2.91$, (b) partially covered $Q_{sw} = 4.32$, (c) partially covered $Q_{sw} = 8.4$, and (d) slightly covered $Q_{sw} = 19.4$. From top to bottom: Output voltage (50 V/div), output current (2 A/div), and resonant capacitor voltage (50 V/div).

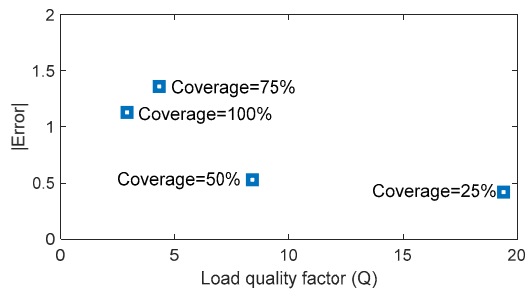

Fig. 7. Measured error as a function of the quality factor position.

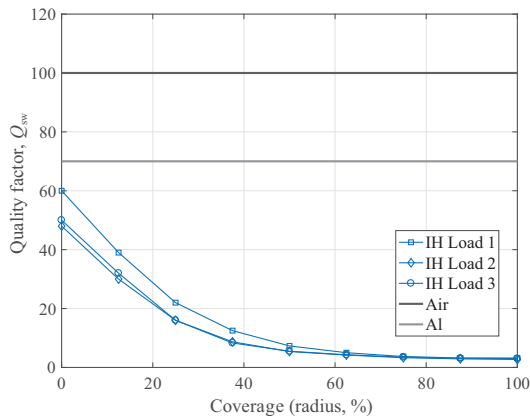

Fig. 8. Quality factor as a function of the coverage percent for different IH loads, aluminum, and air.

IV. CONCLUSIONS

In this paper, an accurate and cost-effective method for detecting induction heating loads has been proposed and experimentally verified. It relies on the calculating of the quality factor of the resonant tank using a simplified approach measuring the resonant capacitor voltage, enabling an efficient implementation. The proposed methodology enables detecting the presence of an induction heating load as well as estimating the coverage percentage without the need of costly and bulky current sensors. This approach provides a versatile implementation which enables the optimization of IH and wireless power transfer systems relying on resonant networks.

ACKNOWLEDGMENT

This work was partly supported by the Spanish MINECO under Project TEC2016-78358-R and Project RTC-2014-1847-6, by the DGA-FSE, and by the BSH Home Appliances Group.

REFERENCES

[1] V. Esteve, J. Jordan, E. Sanchis Kilders, E. Dede, E. Maset, J. Ejea, and A. Ferreres, "Improving the reliability of series resonant inverters for induction heating applications," *IEEE Transactions on Industrial Electronics*, vol. 61, pp. 2564-2572, May 2014.

[2] O. Lucía, J. Acero, C. Carretero, and J. M. Burdío, "Induction heating appliances: Towards more flexible cooking surfaces," *IEEE Industrial Electronics Magazine*, vol. 7, pp. 35-47, September 2013.

[3] P. Di Barba, F. Dughiero, E. Sieni, and A. Candeo, "Coupled field synthesis in magnetic fluid hyperthermia," *IEEE Transactions on Magnetics*, vol. 47, pp. 914-917, May 2011.

[4] O. Lucía, P. Maussion, E. Dede, and J. M. Burdío, "Induction heating technology and its applications: Past developments, current technology, and future challenges," *IEEE Transactions on Industrial Electronics*, vol. 61, pp. 2509-2520, May 2014.

[5] Y. Jian, L. Deyan, L. Chi-Kwan, and S. Y. R. Hui, "A systematic approach for load monitoring and power control in wireless power transfer systems without any direct output measurement," *IEEE Transactions on Power Electronics*, vol. 30, pp. 1657-1667, March 2015.

[6] O. Jiménez, O. Lucía, I. Urriza, L. A. Barragán, P. Mattavelli, and D. Boroyevich, "FPGA-based gain-scheduled controller for resonant converters applied to induction cooktops," *IEEE Transactions on Power Electronics*, vol. 29, pp. 2143-2152, April 2014.

[7] A. M. Stankovic, D. J. Perreault, and K. Sato, "Synthesis of dissipative nonlinear controllers for series resonant DC/DC converters," *IEEE Transactions on Power Electronics*, vol. 14, pp. 673-682, 1999.

[8] M. K. Kazimierczuk and D. Czarkowski, *Resonant Power Converters*. New York: John Wiley & Sons, 2011.

[9] C. Bi, H. Lu, K. Jia, J. Hu, and H. Li, "A Novel Multiple-Frequency Resonant Inverter for Induction Heating Applications," *IEEE Transactions on Power Electronics*, vol. 31, pp. 8162-8171, 2016.

[10] T. Mishima, Y. Nakagawa, and M. Nakaoka, "A Bridgeless BHB ZVS-PWM AC-AC Converter for High-Frequency Induction Heating Applications," *IEEE Transactions on Industry Applications*, vol. 51, pp. 3304-3315, 2015.

[11] H. Sarnago, O. Lucía, A. Mediano, and J. M. Burdío, "Analytical model of the half-bridge series resonant inverter for improved power conversion efficiency and performance," *IEEE Transactions on Power Electronics*, vol. 30, pp. 4128-4143, August 2015.

[12] C. Carretero, J. Acero, R. Alonso, J. M. Burdío, and F. Monderde, "Embedded ring-type inductors modeling with application to induction heating systems," *IEEE Transactions on Magnetics*, vol. 45, pp. 5333-5343, 2009.

[13] J. Acero, R. Alonso, J. M. Burdío, L. A. Barragán, and D. Puyal, "Analytical equivalent impedance for a planar circular induction heating system," *IEEE Transactions on Magnetics*, vol. 42, pp. 84-86, 2006.

[14] O. Jiménez, O. Lucía, I. Urriza, L. A. Barragán, and D. Navarro, "Analysis and implementation of FPGA-based online parametric identification algorithms for resonant power converters," *IEEE Transactions on Industrial Informatics*, vol. 10, pp. 1144-1153, May 2014.

[15] D. Puyal, C. Bernal, J. M. Burdío, J. Acero, and I. Millán, "Versatile high-frequency inverter module for large-signal inductive loads characterization up to 1.5 MHz and 7 kW," *IEEE Transactions on Power Electronics*, vol. 23, pp. 75-87, January 2008.

[16] N. Domingo, L. A. Barragán, J. M. M. Montiel, A. Domínguez, and J. I. Artigas, "Fast power and frequency function estimation for induction heating appliances," *Electronics Letters*, vol. 53, pp. 498-500, 2017.

[17] H. Sarnago, O. Lucía, D. Navarro, and J. M. Burdío, "Operating conditions monitoring for high power density and cost-effective resonant power converters," *IEEE Transactions on Power Electronics*, 2016.