

# Adaptable Reactors for Resource- and Energy-Efficient Methane Valorisation (ADREM)

## Benchmarking modular technologies

### **Emmanouela Korkakaki\*, Stéphane Walspurger, Koos Overwater**

TechnipFMC Process Technology, PO Box 86,  
2700 AB Zoetermeer, The Netherlands

### **Hakan Nigar**

Process & Energy Department, Delft University  
of Technology, Leeghwaterstraat 39, 2628 CB  
Delft, The Netherlands

### **Ignacio Julian**

Institute of Nanoscience of Aragón and  
Department of Chemical and Environmental  
Engineering, University of Zaragoza, Campus  
Río Ebro, I+D+i Building, 50018 Zaragoza,  
Spain

### **Georgios D. Stefanidis**

Process Engineering for Sustainable Systems  
(ProcESS), Department of Chemical  
Engineering, KU Leuven, Celestijnenlaan 200F,  
B-3001 Heverlee, Leuven, Belgium

### **Saashwath Swaminathan Tharakaraman**

Laboratory for Chemical Technology,  
Department of Materials, Textiles and Chemical  
Engineering, Technologiepark 125, 9052 Ghent,  
Belgium

### **Damjan Lašič Jurkovič**

Department of Catalysis and Chemical Reaction  
Engineering, National Institute of Chemistry,  
Hajdrihova 19, SI-1001 Ljubljana, Slovenia

\*Email: [emma.korkakaki@technipfmc.com](mailto:emma.korkakaki@technipfmc.com)

low greenhouse gas emissions, Adaptable Reactors for Resource- and Energy-Efficient Methane Valorisation (ADREM) focused on the development of modular reactors that can upgrade methane-rich sources to chemicals. Herein we summarise the main findings of the project, excluding in-depth technical analysis. The ADREM reactors include microwave technology for conversion of methane to benzene, toluene and xylenes (BTX) and ethylene; plasma for methane to ethylene; plasma dry methane reforming to syngas; and the gas solid vortex reactor (GSVR) for methane to ethylene. Two of the reactors (microwave to BTX and plasma to ethylene) have been tested at technology readiness level 5 (TRL 5). Compared to flaring, all the concepts have a clear environmental benefit, reducing significantly the direct carbon dioxide emissions. Their energy efficiency is still relatively low compared to conventional processes, and the costly and energy-demanding downstream processing should be replaced by scalable energy efficient alternatives. However, considering the changing market conditions with electrification becoming more relevant and the growing need to decrease greenhouse gas emissions, the ADREM technologies, utilising mostly electricity to achieve methane conversion, are promising candidates in the field of gas monetisation.

## 1. Introduction

The tremendous growth of the global economy is directly related to increased energy demand and (currently) high greenhouse gas emissions. Substantial reduction in global emissions is required to minimise environmental hazard and ongoing climate change. Legislations are pushing for energy transition, replacing fossil fuels with alternatives for reduced emissions. Wind, solar and biomass are key-players for the energy future, as

Following the global trend towards increased energy demand together with requirements for

depicted in the latest statistics and forecast (1, 2). According to one of the possible energy transition scenarios, to accommodate the increasing energy demands with the least environmental impact, renewable sources will rapidly grow their share in the energy mix, while natural gas is foreseen to maintain a key role during the transition phase (1, 2). However, natural gas contributes to CO<sub>2</sub> emissions, with approximately 7 billion tonnes of CO<sub>2</sub> being produced on a yearly basis, with approximately 5% of this amount attributed to flaring (Figure 1). This percentage adds to both the environmental problem and to the waste of an important resource, methane (3–5).

ADREM (EU project Horizon 2020 No. 636820), focused on the development of novel reactor concepts that are capable of converting methane to higher chemicals with a compact, modular and flexible process design. The University of Zaragoza (UniZar), Spain; Delft University of Technology (TU Delft), The Netherlands; and SAIREM, Décines-Charpieu, France, investigated microwave reactor technology for methane non-oxidative coupling (MNOC). Katholieke Universiteit Leuven (KU Leuven), Belgium and Kemijski inštitut in Ljubljana, Slovenia, worked with plasma technology for methane non-oxidative coupling and dry reforming respectively. Ghent University, Belgium, investigated the gas solid vortex reactor (GSVR) for oxidative methane coupling (OCM). In the present paper, we give an overview of the

technologies that were developed, the status, the main bottlenecks and the path forward.

## 2. Technology Breakthrough

### 2.1. Microwave Non-Oxidative Methane Coupling with Both a Multistage Monomodal Reactor and with a Travelling Wave Reactor

Two different reactor setups were used for MNOC: (i) multistage monomodal, and (ii) travelling-wave. The microwave concept relies on highly energy-efficient selective heating of catalyst since the required heat for the endothermic reaction is directly generated within the microwave-susceptible catalysts or catalytic support. The endothermic reaction occurs only at the (heated) catalytic surface, eliminating possible side reactions and unnecessary pre-heating of the gases. Julian *et al.* (6), focused on structured reactors, with various monolith configurations and compositions. The structured catalysts have low pressure drop and minimum mass transfer limitations. Methane at ambient conditions was supplied to the heated structured catalyst to produce C<sub>2</sub>-C<sub>10</sub> (Figure 2). Julian *et al.* (6) reached the optimum performance of 15% methane conversion, with a yield to C<sub>2</sub> and C<sub>6</sub> equal to 6% for both compounds, comparable to conventionally heated non-oxidative methane coupling. The tailor-made monolith

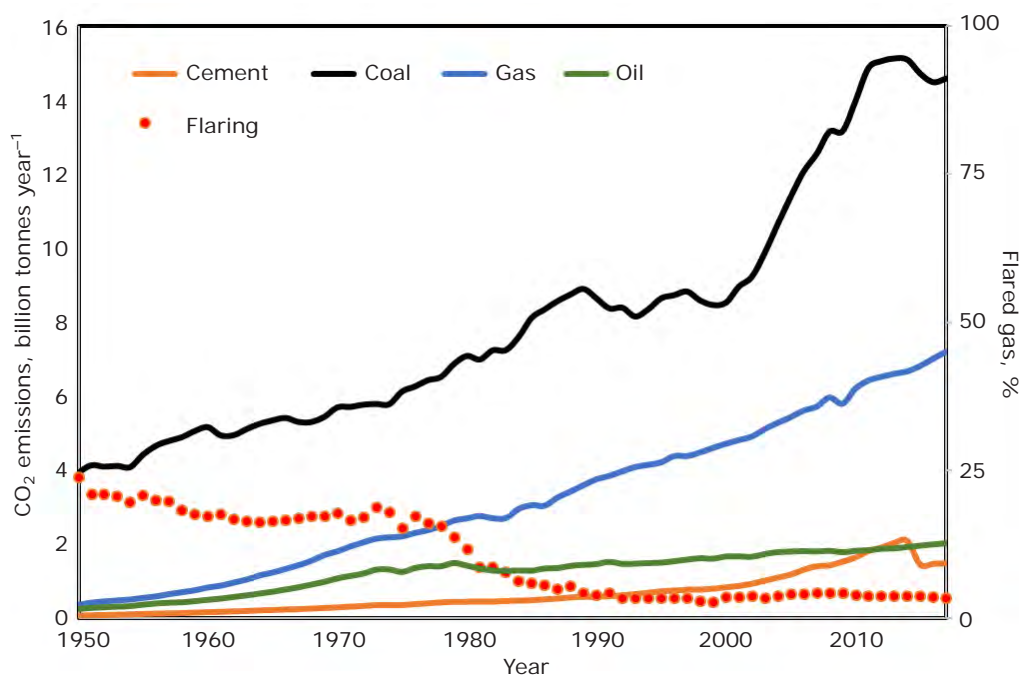

Fig. 1. CO<sub>2</sub> annual emissions from cement, coal, gas and oil and flaring percentage on gas (5)

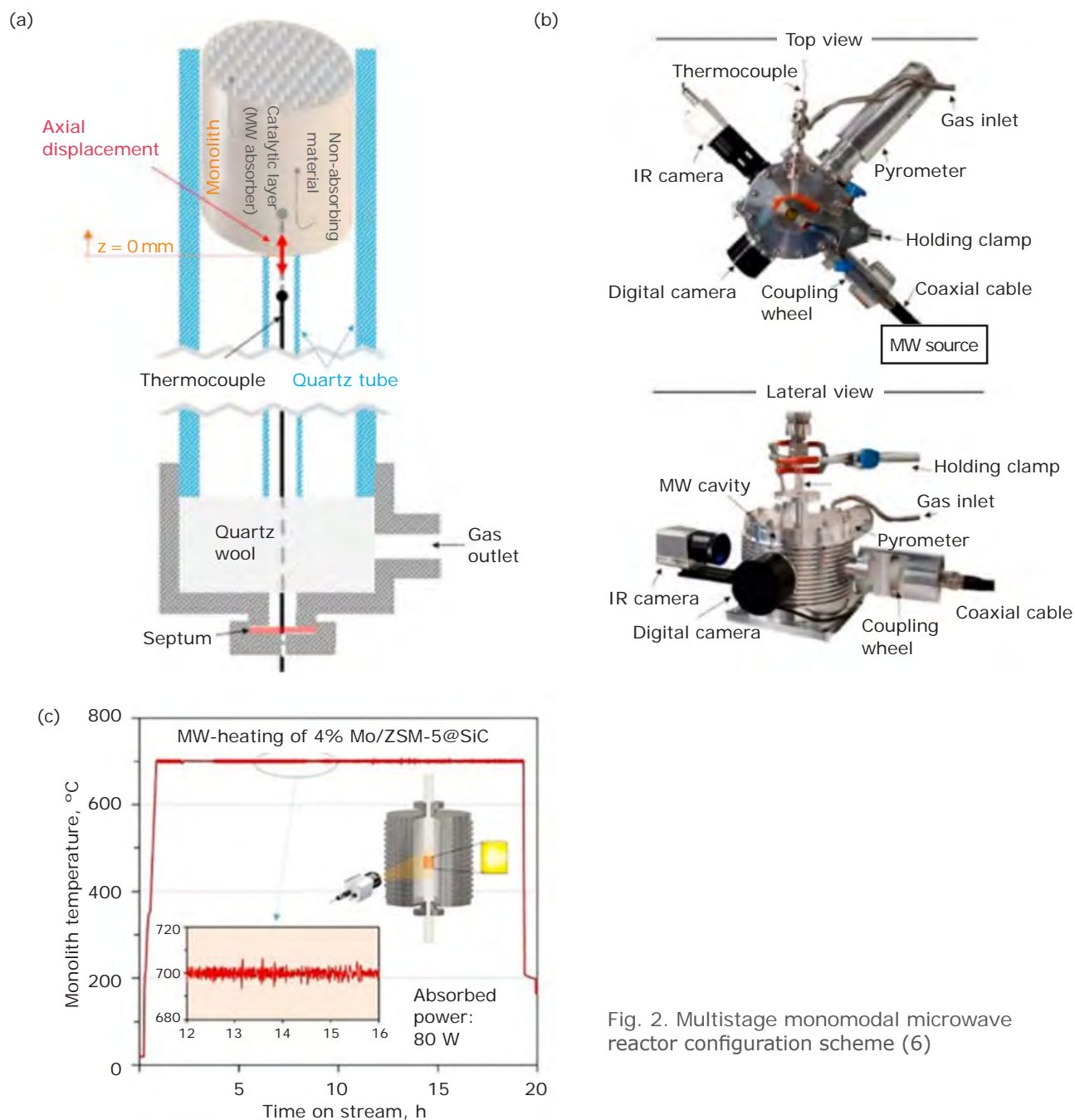

Fig. 2. Multistage monomodal microwave reactor configuration scheme (6)

(Mo/ZSM-5@SiC) showed a stable performance of reaction-regeneration for approximately 20 h. The main limitation for continuous operation is coke deposition that deactivates the catalyst and creates hotspots. For TRL 5 validation, an upscaled fully automated system has been successfully tested at the Danish Technology Institute.

TU Delft investigated the same chemistry in the travelling-wave microwave reactor concept. In contrast to mono- and multi-mode resonant applicators, the travelling-wave reactor concept has the potential for generating highly uniform

microwave heating by avoiding resonant conditions (7, 8). Since the travelling-wave reactor ensures uniformity of the electromagnetic field inside the reactor, it enables energy-efficient operation, with a flexible (in terms of upscaling potential) design. TU Delft has designed and constructed the travelling-wave reactor and has simulated its performance. Also, heating tests with 5 mm beta silicon carbide extrudates, supplied from SiCat-Germany, have been conducted in the fixed-bed configuration (Figure 3). The microwave heating experimental results showed that uniform

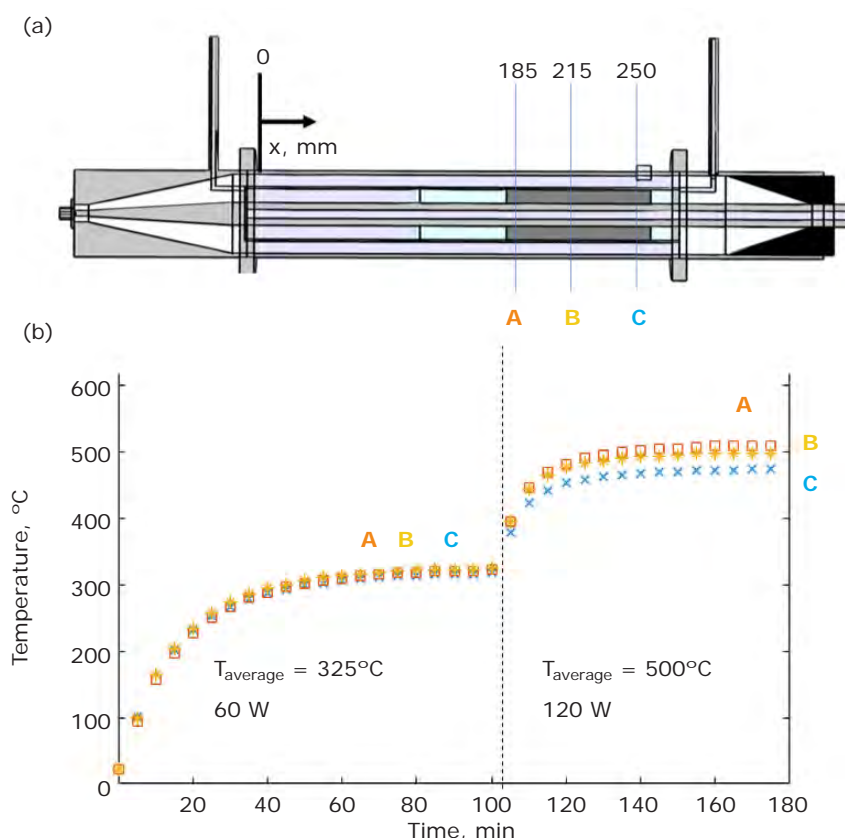

Fig. 3. (a) Schematic view of the travelling-wave microwave reactor; (b) transient temperature profile. A, B and C represent the temperature measurement points

temperature distribution can be achieved, with average temperatures of 325–500°C with MW inputs of 60 W and 120 W respectively.

## 2.2. Plasma Non-Oxidative Coupling of Methane

MNOC was investigated in nanosecond pulsed discharges (NPD). Plasma, a cloud of chemically active species namely radicals, ions and excited molecules, is initiated *via* (high energy) electron and molecule collisions. These active species can rapidly undergo several chemical reactions to form other products at ambient temperature and pressure conditions. Eventually, the electric energy is channelled into chemical rather than into gas heating, minimising heat losses. Two plasma-assisted process alternatives have been developed and optimised by Stefanidis and co-workers aiming for: (i) a direct gas conversion to ethylene at elevated pressures without utilising any catalyst (9); and (ii) a stepwise gas conversion to acetylene followed by acetylene-to-ethylene catalytic hydrogenation in the post-plasma zone (10) (Figure 4). Different plasma geometries (co-axial and plate-to-plate) and operating conditions (i.e. pulse frequency, inter-electrode gap and pressure) towards high ethylene yields at relative low energy costs have also

been tested. Collectively, in case of serial plasma-catalyst integration and global thermal insulation of the plate-to-plate reactor system, the ethylene energy cost can be as low as  $\sim 900 \text{ kJ mol}^{-1} \text{ C}_2\text{H}_4$  for  $\sim 32\% \text{ C}_2\text{H}_4$  yield. Periodic air plasma ignition enables reactor decoking, allowing for extended operating periods (11). The plate-to-plate reactor, unmanned and fully automated has been tested (TRL 5) in Johnson Matthey's facilities.

## 2.3. Oxidative Coupling of Methane with a Gas-Solid Vortex Reactor

In OCM, methane reacts with oxygen to produce C2 compounds together with carbon monoxide and  $\text{CO}_2$  in an exothermic reaction. To avoid formation of oxygenates, short and controlled residence times are preferred. In the GSVR, a rotating fluidised bed is obtained by tangential gas injection at high velocities (Figure 5). Centrifugal force counteracts the drag force, resulting in a dense fluidised bed and a higher gas solid slip velocity, increasing heat, mass and momentum transfer and decreasing the gas residence time (12). The gas enters the GSVR through a single inlet and is distributed around the annulus. Gas enters tangentially into the reaction chamber *via* rectangular slots and then exits the reactor through a central exhaust (Figure 6). The

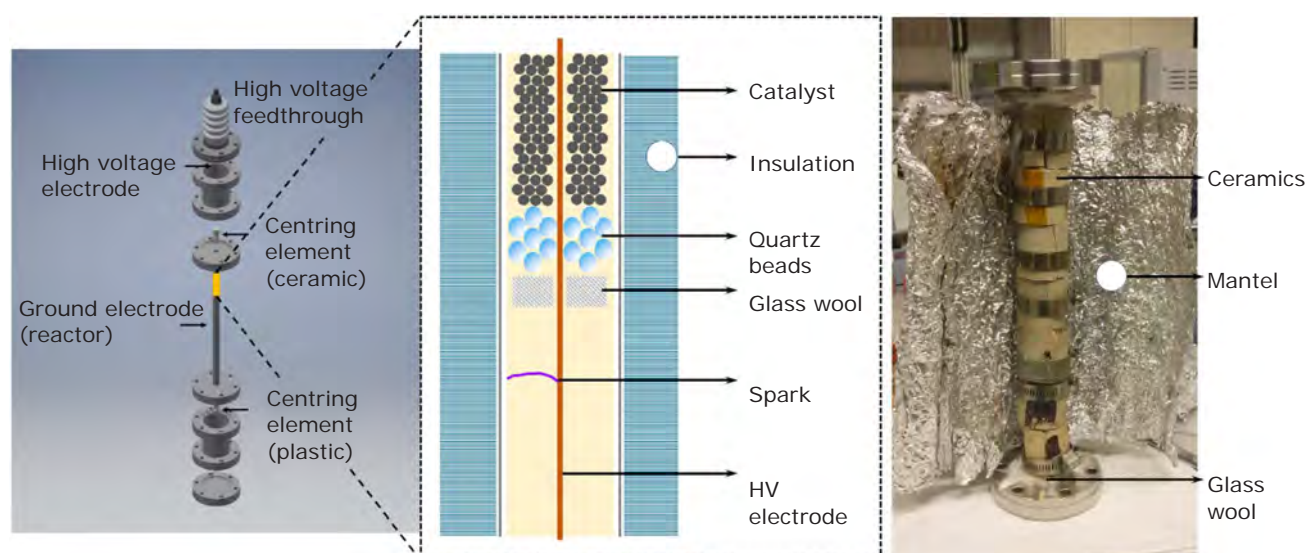

Fig. 4. Hybrid plasma reactor configuration scheme (10)

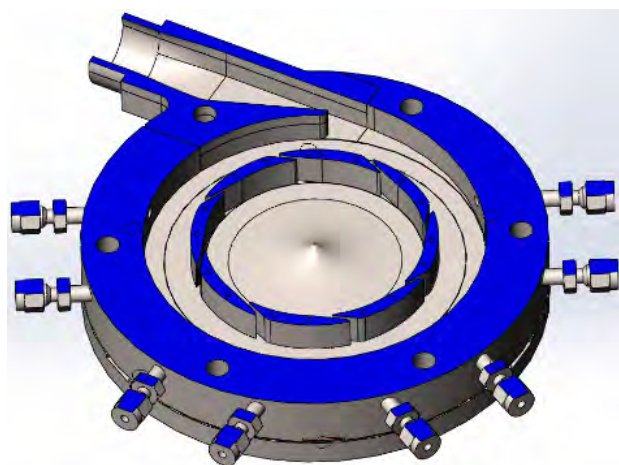

Fig. 5. Schematic representation of GSVR

reactor combines the characteristics of plug flow kinetics for the gas phase with continuous stirred tank reactor (CSTR) kinetics for the fluidised bed. High throughputs can be accommodated in a small footprint, leading to an intensified OCM process. However, the high exothermicity of the OCM reaction could potentially make the reactor system hard to control, but also creates opportunities for operation on an ignited branch (13). The high reaction temperature, the high solid velocity and the low space times require catalysts with high attrition resistance, high thermal stability, high activity and suitable size distribution. To this end, a novel catalyst material was developed that combines high activity with excellent mechanical and thermal stability. Catalytic tests in a fixed bed

reactor demonstrate a stable methane conversion rate of  $100 \text{ mmol CH}_4 \text{ kg}_{\text{cat}}^{-1} \text{ s}^{-1}$  at  $850^\circ\text{C}$ , with a C2 selectivity exceeding 60%. Simulations indicate that for inlet temperature of  $520^\circ\text{C}$  and an oxygen-to-methane molar ratio of 1:5, a methane conversion of 55% and a C2 selectivity of 47% can be expected.

Initial proof-of-concept experiments have verified the potential of this reactor for OCM.

## 2.4. Plasma Dry Reforming

Dry reforming was evaluated with plasma technology. The system at Kemijski inštitut is a spark plasma reactor, designed such that the inlet tubes act also as electrodes, which enables the introduction of reactant gases directly into the discharge for maximum gas coverage with plasma. The reactor design also allows for the usage of a unique structured porous foam nickel-based catalyst, which was designed at Johnson Matthey, to further convert the energy provided by the electron collisions in plasma. The process was evaluated under different operating conditions:

- reagent ratios
- gas flow rates
- applied plasma voltages and
- catalysts.

It was determined that the optimal  $\text{CH}_4:\text{CO}_2$  reagent ratio is 2:3, at which 90% methane conversion was reached. The product syngas  $\text{H}_2:\text{CO}$  ratio can be tuned by increasing the  $\text{CH}_4$  content in the feed, however, significant coke generation was observed under such conditions. Coking could destabilise

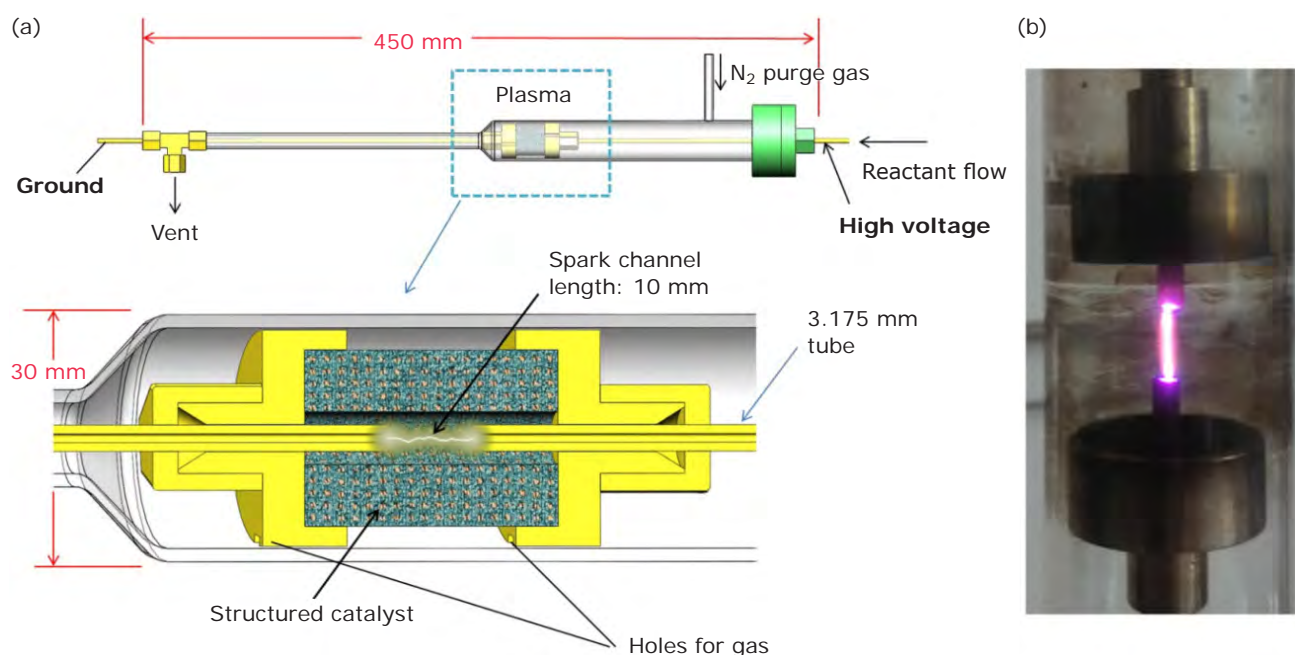

Fig. 6. The spark plasma reactor used for dry reforming: (a) reactor design; and (b) photo of the discharge in pure nitrogen

the plasma, so an efficient strategy was developed where coke is removed *in situ* by periodically applying pure CO<sub>2</sub> plasma while maintaining a high duty-cycle.

### 3. Benchmarking New Technologies

To assess the potential of the reactors that were developed in ADREM, a case study of valorising associated (flared) gas has been simulated. The feed is rich in methane (>95% vol) with a flowrate of 1000 Nm<sup>3</sup> h<sup>-1</sup>. All the cases include pretreatment for sulfur and CO<sub>2</sub> removal, while for comparison purposes, the downstream processing follows the conventional approach, with either cryogenic separation (for C<sub>2</sub>+ hydrocarbons) or methanol loop (for syngas to methanol conversion). The end product consists either of mixtures of products (i.e. ethane/ethylene) or product at low purity (for example, raw methanol). Further purification in centralised units is necessary to reach the required quality.

The specific energy (Table I) of each technology consists of the reactors' energy demands and the downstream processing (DSP) intensity (the latter being directly related to methane conversion and productivity). The microwave and GSVR technologies have the lowest specific energy consumption, as a result of the upscaled microwave reactor design of SAIREM and the

exothermic OCM reaction respectively. The plasma technology is more energy intensive predominantly due to numbering up of the modules in order to accommodate the required flow. The technologies that produce BTX and ethylene would obviously benefit from replacement of the cryogenic separation by energy-efficient and modular alternatives (for example, ethane/ethylene membranes (14) or adsorption based technology) to decrease the energy demand. For the plasma dry reforming, the product syngas enables alternative downstream processing (for example, a methanol reactor), but the high operational pressure of such a design still adds to the overall energy efficiency and complicates the modularity of the plant. However, the modular methanol reactor is already available in commercial scale (3).

The capital intensity (Table I) is a function of the conversion and selectivity and the ease of upscale. On one hand, low conversion results in a large recycle flow (due to unconverted methane), and more energy-demanding units. On the other hand the numbering up strategy to accommodate the required throughput implies high capital requirements for all the technologies. The MW reactor with the realised upscaled concept and the GSVR that can accommodate high flowrate, appear to be the most cost-competitive at the present development stage. Collectively, the first step of further development for the ADREM reactors is

Table I Overview of the ADREM Technologies

	Unit	Microwave MNOC – UniZar	Plasma MNOC	GSVR	Plasma dry reforming
<b>CH<sub>4</sub> conversion</b>	mol%	15	35	55	81
<b>Product</b>		C6/C2	C2	C2	H <sub>2</sub> /CO
<b>Yield<sup>a</sup></b>	mol%	6/6	28	26	NA
<b>Coking</b>	%	13	7	0	19
<b>Specific energy<sup>b</sup></b>	kJ C-mol <sup>-1</sup> of product	392.7	1127	603.4	1091.9 <sup>c</sup>
<b>Capital investment</b>	–	High	Very high	Medium	Very high
<b>Ease of scale up</b>	–	Medium	Medium	Good	Medium
<b>DSP cost</b>	–	Very high	Very high	Very high	Very high
<b>Utilities use</b>	–	High	High	High	High
<b>CO<sub>2</sub> emissions<sup>d</sup></b>	–	Low	Low	Medium	Low

<sup>a</sup> Hydrocarbon yield is defined as the product of conversion by selectivity

<sup>b</sup> The specific energy is calculated including up- and down-stream processing of reservoir gas (that is typically flared). Pre-treatment of the gas includes desulfurisation and CO<sub>2</sub> removal, while downstream consists of H<sub>2</sub> removal (optional) and cold box (for the C2+ products) or methanol loop (for the methanol product)

<sup>c</sup> The energy is expressed in kJ per mol methane

<sup>d</sup> CO<sub>2</sub> emissions from electricity are assumed to be zero (green electricity)

to improve the reactor performance in terms of conversion and selectivity.

Compared to flaring, for all the technologies the CO<sub>2</sub> emissions are low (25–80% decrease, depending on the technology), with the highest CO<sub>2</sub> emissions coming from the GSVR reactor (where CO<sub>2</sub> is a product) and the lowest emissions coming from plasma dry reforming (where CO<sub>2</sub> is the reactant). Applying the ADREM technologies in situations associated with gas flaring in remote locations will have a huge environmental benefit when renewable electricity is available in abundance.

#### 4. Conclusions and Path Forward

During the project, partners have been developing new small scale gas-to-liquids (GTL) technology, where methane is valorised to chemicals. Two of the reactor technologies have been successfully demonstrated in TRL 5 (microwave and plasma). With tighter regulation on greenhouse gas emissions and flaring, there are clear opportunities for the ADREM technologies to find applications. The UniZar reactor has efficiently been upscaled (32x) and the GSVR reactor is designed in such a way that it can accommodate relatively high flowrate. The plasma reactors (both NPD and dry reforming) showed the highest conversions and selectivities, but they still need to improve the upscale strategy.

For further upscaling and demonstration of the technologies, it is required to improve productivity, conversion and mitigation of carbon formation. Different operating conditions (in terms of pressure, temperature, catalysis or reactor geometry) or *in situ* product separation could potentially enable higher conversions and selectivity and are planned for the next steps of development. Improving the reactor performance will decrease the unit size for each technology and simplify the downstream processing. Downstream processing is an essential point that should be developed and optimised once the selectivity and conversion are improved.

#### Acknowledgements

The authors wish to thank European Union's Horizon 2020 research and innovation programme under the grant agreement No 636820.

#### References

1. N. Z. Muradov and T. N. Vezirođlu, *Int. J. Hydrogen Energy*, 2008, **33**, (23), 6804
2. S. Sgouridis, D. Csala and U. Bardi, *Environ. Res. Lett.*, 2016, **11**, (9), 094009
3. 'Global Gas Flaring Reduction Partnership (GGFR): Improving energy efficiency & Mitigating Impact on Climate Change', The World Bank, Washington, DC, USA, 2011

4. T. A. Boden, G. Marland and R. J. Andres, 'Global, Regional, and National Fossil-Fuel CO<sub>2</sub> Emissions', Carbon Dioxide Information Analysis Center, Oak Ridge National Laboratory, Oak Ridge, Tennessee, USA, 2010
5. H. Ritchie and M. Roser, 'CO<sub>2</sub> and Greenhouse Gas Emissions', Our World in Data, Oxford, UK, May, 2017
6. I. Julian, H. Ramirez, J. L. Hueso, R. Mallada and J. Santamaria, *Chem. Eng. J.*, 2019, **377**, 119764
7. "Alternative Energy Sources for Green Chemistry", eds. G. Stefanidis and A. Stankiewicz, The Royal Society of Chemistry, Cambridge, UK, 2016, 411 pp
8. A. Stankiewicz, F. E. Sarabi, A. Baubaid, P. Yan and H. Nigar, *Chem. Rec.*, 2019, **19**, (1), 40
9. M. Scapinello, E. Delikonstantis and G. D. Stefanidis, *Fuel*, 2018, **222**, 705
10. E. Delikonstantis, M. Scapinello and G. D. Stefanidis, *Fuel Process. Technol.*, 2018, **176**, 33
11. E. Delikonstantis, M. Scapinello, O. Van Geenhoven and G. D. Stefanidis, *Chem. Eng. J.*, 2020, **380**, 122477
12. A. Gonzalez-Quiroga, P. A. Reyniers, S. R. Kulkarni, M. M. Torregrosa, P. Perreault, G. J. Heynderickx, K. M. Van Geem and G. B. Marin, *Chem. Eng. J.*, 2017, **329**, 198
13. L. A. Vandewalle, I. Lengyel, D. H. West, K. M. Van Geem and G. B. Marin, *Chem. Eng. Sci.*, 2019, **199**, 635
14. M. Rungtha, C. Zhang, W. J. Koros and L. Xu, *AIChE J.*, 2013, **59**, (9), 3475

---

## The Authors



Emmanouela (Emma) Korkakaki is a product development engineer at TechnipFMC. She graduated from the Chemical Engineering Department of the Aristotle University of Thessaloniki, Greece, and holds a PhD in Environmental Biotechnology from TU Delft, The Netherlands. In her current role she investigates sustainable alternatives to conventional petrochemical processes with heat transfer optimisation, decreasing energy requirements and CO<sub>2</sub> emissions.



Stéphane Walspurger holds a PhD from the University of Strasbourg, France. In 2006–2007 he contributed to research projects for "Beyond Oil and Gas: The Methanol Economy" with Nobel laureate Professor George Olah and Professor Surya Prakash at the University of Southern California, USA. In the period 2008–2013, as a Scientist at the Energy Research Centre of the Netherlands, he contributed to the scale-up of novel CO<sub>2</sub> capture. Since 2014, he has been working on the development of new products to extend TechnipFMC's technology portfolio and ensures TechnipFMC delivers cutting edge tailored technologies for hydrogen and syngas production to its clients.



Koos Overwater is TechnipFMC's Vice President Hydrogen Product Line and Technologies, supporting and promoting at corporate level the technology and business development of the hydrogen product line. Koos is located at the TechnipFMC office in Zoetermeer, The Netherlands. Koos is also Vice President New Technologies, responsible for the development of new technologies within the Zoetermeer office. Koos holds a master's degree in chemical engineering from TU Delft, The Netherlands.



Hakan Nigar received his PhD degree, *cum laude*, in Chemical and Environmental Engineering in 2017 from University of Zaragoza, Spain. Currently, he works as a Post-Doctoral Researcher at the Process and Energy Department at TU Delft, The Netherlands. He focuses on the two most critical societal challenges, which are environment and energy. He is interested in developing and designing environmentally friendly and energy-efficient chemical processes. He does fundamental research in microwave heating, heterogeneous catalysis, adsorption-desorption processes, multiphase flows and mesoscale transport phenomena. Hakan is also experienced in simulation and modelling of multi-physics processes, including electromagnetic waves, fluid dynamics, heat-mass transfer and chemical kinetics.



Ignacio Julian is Senior Researcher at the Institute of Nanoscience of Aragón, Spain. He obtained a PhD in Chemical Engineering from the University of Zaragoza in 2015 and is co-author of more than 20 papers in peer-reviewed journals in this field. His research interests include process intensification devoted to heterogeneous catalysis for light hydrocarbons valorisation, nanomaterials production, multiphase reactors design and modelling, microwave-assisted heating, computational fluid dynamics, membrane technology and adsorption/desorption processes, among others.



Professor Georgios Stefanidis is Associate Professor at KU Leuven, Belgium, with a PhD degree in the same field from Ghent University, Belgium. His research interests revolve around process intensification, mainly by means of alternative energy forms and transfer mechanisms (microwaves, plasma and light). He has been guest editor of two special issues on these topics in the *Chemical Engineering and Processing: Process Intensification* journal (Elsevier) and he is co-author of more than 40 peer-reviewed journal papers.



Saashwath Swaminathan Tharakaraman obtained his Bachelor of Technology degree from National Institute of Technology, Tiruchirappalli, India, in 2012. He then moved to the Netherlands to start his masters studies at TU Delft. After graduation in 2014, he started pursuing his doctoral studies at the Laboratory of Chemical Technology, Ghent University. Currently he is working on development of catalysts for oxidative coupling of methane.



Damjan Lašič Jurković finished his bachelors and masters degrees in the Chemical Engineering Faculty of Chemistry and Chemical Technology at the University of Ljubljana, Slovenia. Since 2015 he has been employed at the Department of Catalysis and Chemical Reaction Engineering at National Institute of Chemistry, Ljubljana, as a researcher where he continues to work to date after finishing his PhD in 2020. His work focuses mainly on plasma and plasma-catalytic activation of methane, as well as reaction kinetics and reactor modelling.